



AS-i Safety at Work Programm

Your solution for sensor and actuator wiring

AS-Interface

Benefits and features

AS-Interface is the innovative solution for sensor and actuator wiring, regardless of whether standard or safety-relevant applications are concerned. Modern systems must nowadays be inexpensive, flexible, service-friendly and able to detect faults.

All these properties are incorporated in the AS-Interface right from the start. The simplicity and safety in installation, operation and maintenance as well as the long-term potential for reducing costs speak for themselves.

Only one yellow, two-wire ribbon cable with reverse polarity protected profiling is laid to transmit the energy and data to up to 248 inputs and 248 outputs. Suitable slaves can be plugged in any position according to the "plug & play" principle. The contact between the device connection and the cable is made by the so-called piercing technology. Here, the contacts pierce the insulation through to the wire. The given geometry of the BUS adapter and the cable cross-section prevent installation errors.

Overview of the BERNSTEIN AS-i safety components



The AS-Interface cannot and is not intended to replace the existing and proven bus systems. AS-Interface is a standalone solution **or** an extension of the existing system.

Linking to PROFIsafe, PROFIBUS, PROFINET, Ethernet, CAN, EtherCAT, DeviceNet, Interbus, RS-232 and CC-Link is possible without any problems by gateways. AS-Interface and every sensor/actuator connected to it then behave as slaves of the master bus system.

The high integration capability into other networks simplifies the modular set-up of automation networks. Owing to the many providers of components of this non-proprietary system, almost every type of sensor and actuator is available with AS-i interface.

This enables AS-i systems to be established in all conceivable branches, from automation technology and process technology, ship building and commercial vehicles to building technology.

In addition to the advantages already mentioned, safety systems up to PL e/SIL 3 can also be implemented with AS-i as described on the following pages.

AS-Interface is standardised in accordance with EN 50295 and IEC 62026-2

General technical data

- **Voltage range:** 26,6 V bis 31,6 V
- **AS interface specification:** Profile S-0.B
 - IO-Code: 0 x 0
 - ID-Code: 0 x B
 - ID-Code 1: 0 x F
 - ID-Code 2: 0 x E
- **Plug assignment**

	Without Aux	With Aux
- Pin 1	AS-i +	AS-i +
- Pin 2	Frei	Aux -
- Pin 3	AS-i -	AS-i -
- Pin 4	Frei	Aux +
- **AS-i adress:** Preset address 0

The mechanical switches are always equipped with 2 positive break contacts \rightarrow as a slow action element. Jump switch systems are available on request

Safety figures

	PL according to EN 13849 / SIL according to EN 62061 up to	Cat.	B10d Action
Ti2	c*	1	6 Mio
SKT, SK	c*	1	2 Mio
SLK	c*	1	2 Mio
SHS3	c*	1	2 Mio
SRM	c / e**	1 / 4**	0.2 Mio
MAK 42, MAK 52, MAK 53	e	4	20 Mio
CSMS Reed	e	4	20 Mio
Emergency stopping	e	4	0.1 Mio

* By fault exclusion according to EN 13849-1 and EN 13849-2, PL d can be achieved.

By using 2 safety switches and mutual monitoring, Cat. 4, PL e can be achieved.

** By maximum actuation of 6050 cycles over the total product life.

Safety at Work, the Safety Bus

Safety functions up to PL e according to EN 13849 and SIL 3 according to 62061 can be implemented with AS-Interface Safety at Work. The safety-relevant data is transmitted on a two-wire ribbon cable and therefore minimises the wiring effort. This along with the simplicity in planning, installation and maintenance is one of the main reasons why AS-i Safety at Work is the most frequently used safety bus.

For a Safety at Work system you only require the safety-oriented slaves, a master and a safety monitor. The latter dynamically monitors the safe users and switches off the safety path in the event of an error or at the prompting of a safety function. The safety application is created with the Windows program "ASIMON" and then loaded into the safety monitor. Changes and extensions to the safety application can be made by a software adaptation combined with the piercing connection technology in a few seconds, even in a safety application program.

MANY FEATURES AT A GLANCE

- The use of the AS-i Bus considerably reduces the planning and documentation effort because only minimum circuit diagrams have to be drawn. In addition to the drastic reduction in the installation time in comparison with standard wiring, numerous components such as safety relays, terminal boxes and thus their processing as well as integrated screw connections and terminals and PLC I/Os plus an enormous quantity of cables are saved. This leads in turn to a reduction in the amount of space required in the control cabinet, cable ducts and machines.
- The systems can be commissioned fast thanks to the simple and reliable connection technology. If changes have to be made sooner or later, this is no problem as long as the maximum number of slaves has not been reached.
- Just connect the necessary slave to the cable and transfer it to the configuration by laptop or directly on the master. Finished.
- Since it is only a two-wire cable, the AS-i system can be adapted optimally to a modular machine.
- System data can also be read out of the slaves or changed by connecting with a master bus system. This enables remote maintenance to the smallest element of an automation safety system.



Safety technology with AS-i Safety at Work gains efficiency via benchmarking

Strive for an acceptable balance of costs versus benefits over the complete machine life cycle. Take the opportunity to gain a competitive advantage through the technological values of modern safety technology!

Change today to a modern flexible and effective system for your specific safety needs. We can help you to optimize your machines and installations when using AS-Interface Safety at Work products from BERNSTEIN.

If you want to experience the efficient features of AS-i Safety at Work in your machines and installations, then simply talk to us!

With AS-i safety you sail in safe waters!

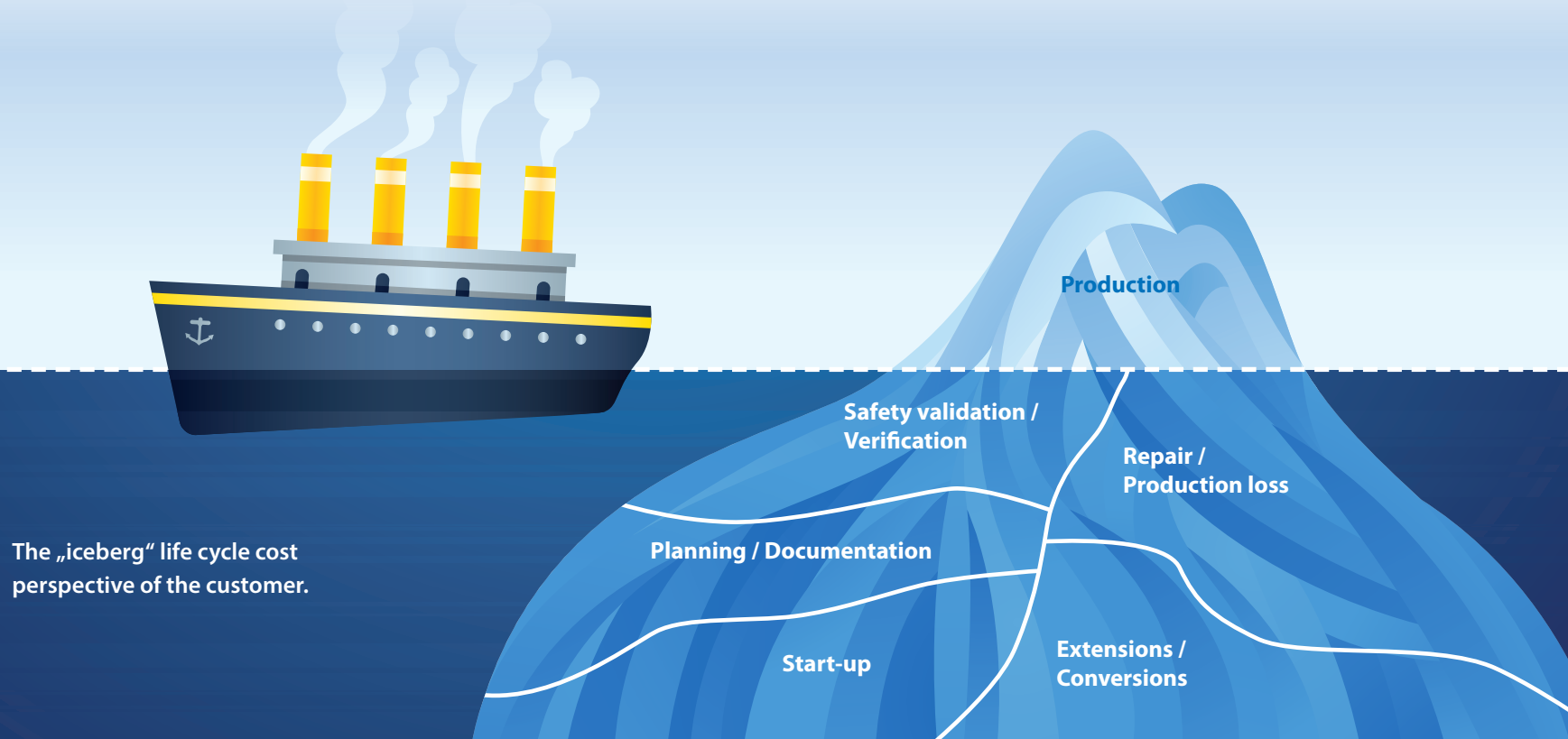

The „iceberg“ life cycle cost perspective of the customer.

A recent study¹ indicated:

If AS-Interface Safety at Work is used, this safety technology is the most cost effective choice over the complete machine life cycle!

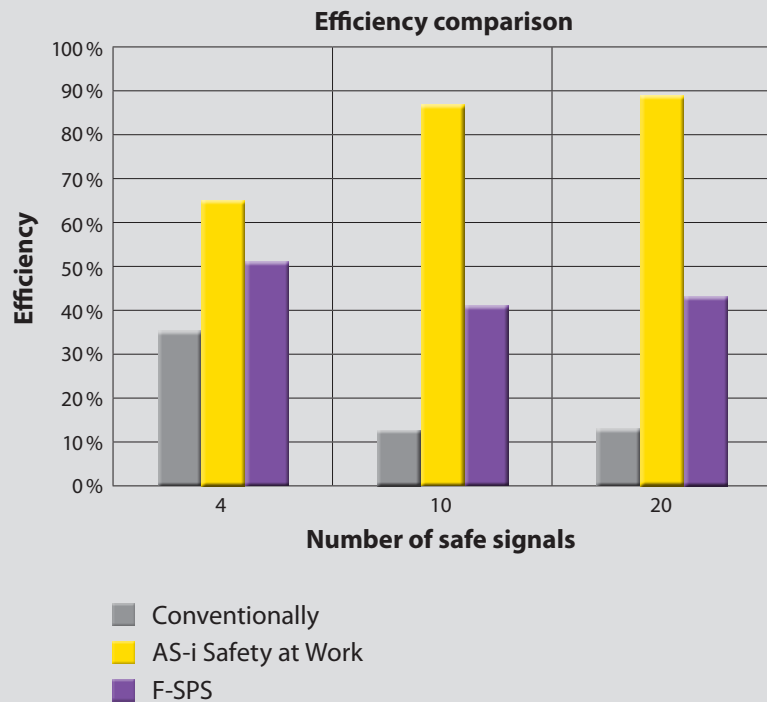

¹ Master thesis on the topic of „Erarbeitung eines Bewertungsmodells für Anlagen mit einer AS-i Sicherheitskette“ at the Ostwestfalen-Lippe University

Comparison of Safety Technology System Costs

Compared to conventional wiring AS-i Safety even pays off in small funtion blocks with four safe signals for example.

Costs	Safety	Big * / ** 20 safety signals	Average ** 10 safety signals	Small *** 4 safety signals
Equipment costs	Conventionally	60 %	67 %	77 %
	AS-i Safety	53 %	78 %	86 %
	F-SPS	65 %	75 %	121 %
Labour costs (50 €/h)	Conventionally	40 %	33 %	23 %
	AS-i Safety	3 %	6 %	9 %
	F-SPS	27 %	25 %	19 %
Result	Conventionally	100 %	100 %	100 %
	AS-i Safety	56 %	84 %	95 %
	F-SPS	92 %	100 %	140 %

* F-SPS in combination with PROFIsafe

** AS-i with gateway and integrated safety monitor

*** AS-i with Safety Basis Monitor

Conclusion: AS-i Safety already
pays off in small machines!



AS-i Slaves

Contactless Safety Sensors

Magnetic technology



CSMS Reed

6073200071 AS-i CSMS-R-M-ST
 6073200072 AS-i CSMS-R-S
 6073200077 AS-i CSMS-R-SET

- Safety slave
- Coded actuator (magnetic)
- Switching status indicator
- AS-i status display
- Suitable for concealed installation
- Suitable for harsh environments
- Non-contact operation gives superior life expectancy
- M12 connector

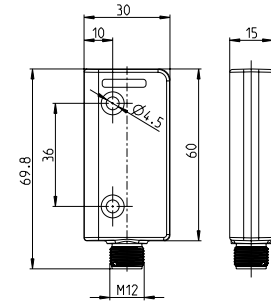

MAK 42

Sensor
 6073200067 AS-i MAK 42
 Actuator
 6402042053 TK-42-CD/2

- Safety slave
- Coded actuator (magnetic)
- Switching status indicator
- AS-i status display
- Suitable for concealed installation
- Suitable for harsh environments
- Non-contact operation gives superior life expectancy

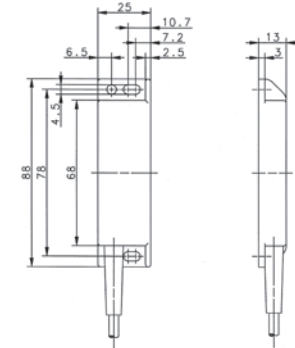

MAK 52

Sensor
 6073200068 AS-i MAK 52
 Actuator
 6402052307 TK-52-CD/2

- Safety slave
- Coded actuator (magnetic)
- Switching status indicator
- AS-i status display
- Suitable for concealed installation
- Suitable for harsh environments
- Non-contact operation gives superior life expectancy

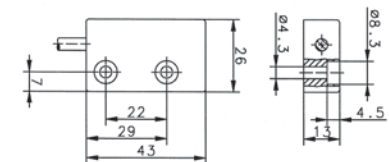

Contactless Safety Sensors



MAK 53

Sensor

6073200091 AS-i MAK 53

6073200092 AS-i MAK 53 ST

Actuator

6402043064 TK-43-CD/2 (plastic housing)

6408043065 TN-43-CD/2 (stainless steel housing)

- Safety slave
- Coded actuator (magnetic)
- Switching status indicator
- AS-i status display
- Suitable for concealed installation
- Suitable for harsh environments
- Non-contact operation gives superior life expectancy

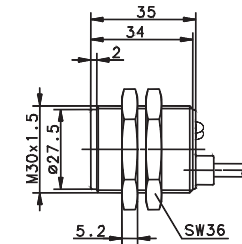

Safety Hinge Switch



SHS3

Stainless steel hinge

6073200011 AS-i SHS3 SA R

6073200013 AS-i SHS3 SR R

Die-cast zinc hinge

6073200081 AS-i SHS3Z SA R

6073200082 AS-i SHS3Z SR R

- Safety slave
- Hinge Switch
- AS-i status display
- Switching point freely adjustable by user over a range of 270°
- Fine adjustment +/- 1.5°
- Freely and repeatedly adjustable switching point
- Stainless steel or die-cast zinc hinge

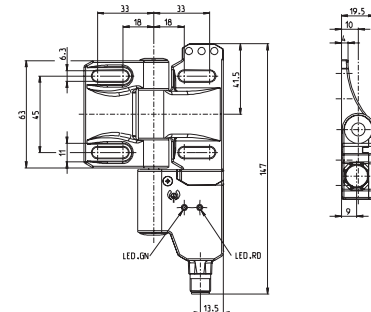

Position safety switches



Ti2

6073403020 AS-i Ti2 Hw

6073402019 AS-i Ti2 Ri w

6073401018 AS-i Ti2 w

- Safety slave
- Smallest switch with integrated AS-i Safety at Work interface
- AS-i status display
- Actuator of the standard program available
- Plastic housing
- Fixing measures according to DIN EN 50047

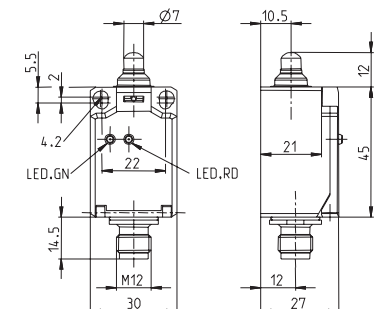

AS-i Slaves

Safety interlock



SLK

Locking principle spring force
6073200058
 AS-i SLK-F-R1-A0-0
 Locking principle magnetic force
6073200057
 AS-i SLK-M-R0-A0-0

- Safety slave
- Interlock switch for safety doors and protective hoods
- Spring force (closed-circuit current) type F and magnetic force (working current) type M
- Status display for the actuating and interlock position
- The status LEDs could alternatively be switched by the control system
- AS-i status display
- Feed-in of the interlock by external power supply system

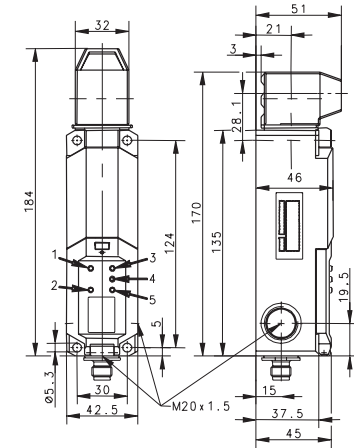

Safety Rope Pull Switch



SRM

6073200009 AS-i SRM-LU-175
6073200010 AS-i SRM-LU-300
6073200007 AS-i SRM-QF-175
6073200008 AS-i SRM-QF-300

- Safety slave
- Rope-pull switch in metal housing
- AS-i status display
- Tensioned length up to 75 meters (version 300) (37,5 meters version 175)
- Quick-Fix quick action clamping head QF available

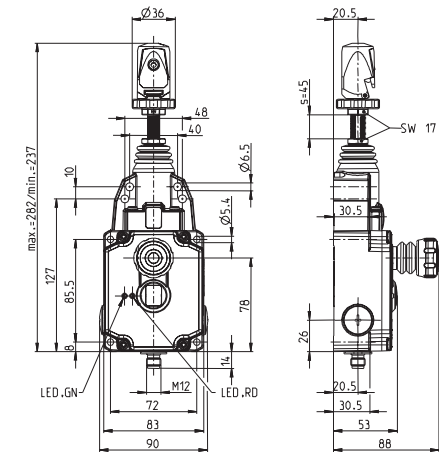

Safety switch with separate actuator



SK

6073205050 AS-i SK F30 M
6073205028 AS-i SK M

- Safety slave
- Safety switch with separate actuator
- AS-i status display
- Plastic housing
- Variable actuator with two actuator openings

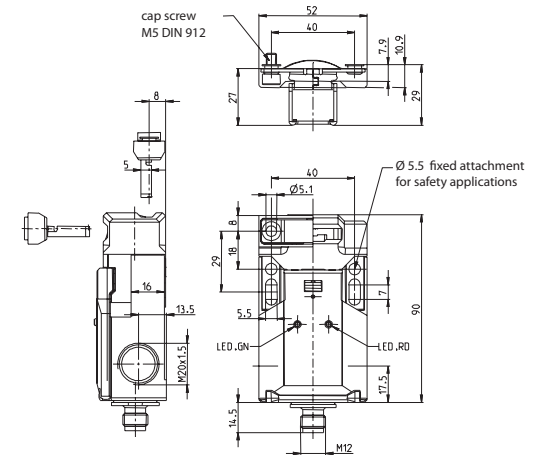

SKT

6073200006 AS-i SKT

- Safety slave
- Safety switch with separate actuator
- Slim and short switch design
- AS-i status display
- Plastic housing
- Rotary head in 90° steps
- 2 actuating entries

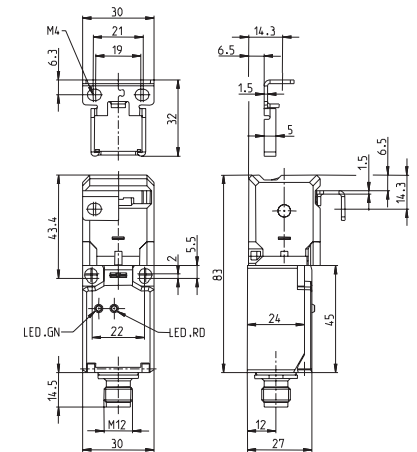

AS-i Slaves

Emergency stop switches and control elements

Emergency stop buttons, illuminated pushbuttons and indicator lamps are available in the new, elegant housing. The housing is **specially designed for 40 mm profile rails** and features a special assembly concept. It can also be used outside the profile rails of course. Start, enable and request buttons can also be connected decentrally to the AS-i system with the control elements. The status of the process can be displayed by the illuminated pushbuttons. With these AS-i solutions, the necessary functions can be placed exactly where they are needed.



Emergency stopping

6073100074
AS-i NOT-HALT

- Emergency stopping button with integrated safety AS-i slave
- With 30 mm emergency stopping button
- Reset via right hand rotation
- 2 coloured status display of emergency stopping button
- M12 connector

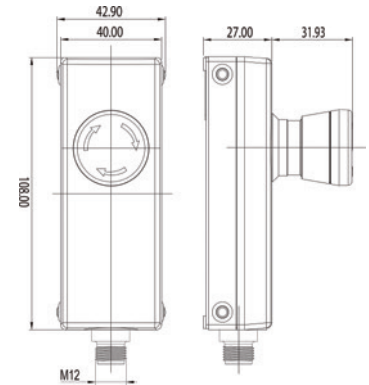

Press button / Signal lamp



Control element

6073100075
AS-i BEDIENELEMENT

- Illuminated push button with AS-i interface slave
- 2 x 22 mm illuminated push button
- M12 connector
- 2 coloured status display per button (programmable via AS-i)

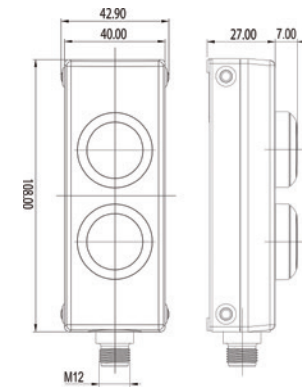

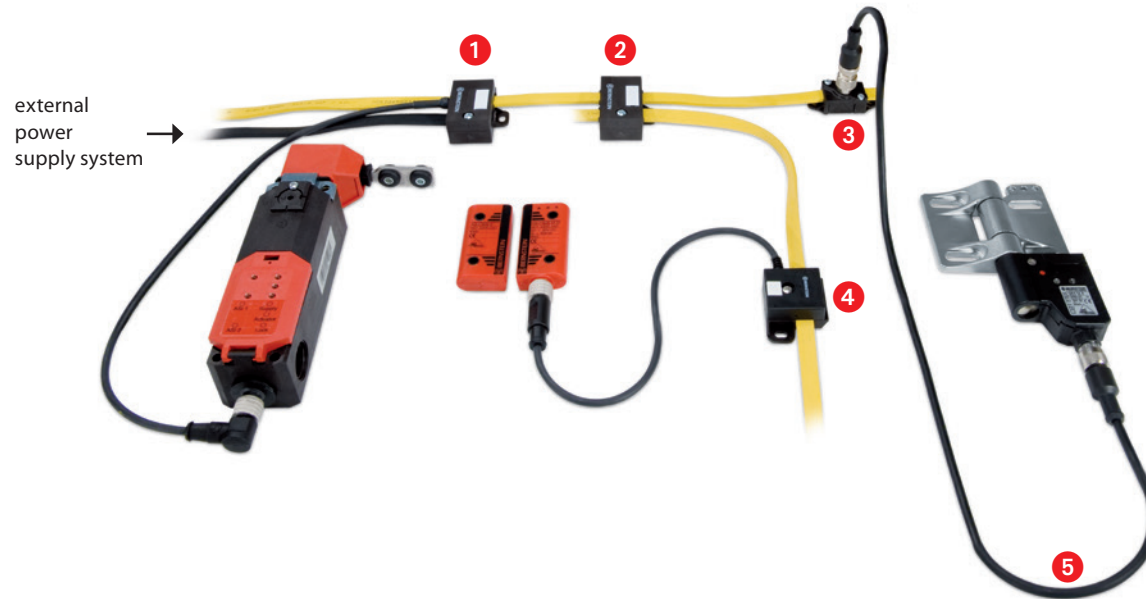

Connecting module 3



6073900042
AS-i KOPPELMODUL M12 SCHR

- For connecting AS-i devices on AS-i profile cable with M12 connecting line
- Codification of the M12 connector turnable over a range of 90°

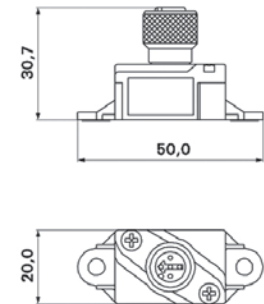

Accessories

Connecting module 4



6073900043
AS-i KOPPELMODUL 1M M12G

6073900087
AS-i KOPPELMODUL 0,3M M12G

- For connecting AS-i devices on AS-i profile cable with an integrated, 1 meter long, ready-made connecting line and M12 straight connecting box
- For connecting AS-i devices on AS-i profile cable with an integrated, 0.3 meters long, ready-made connecting line and M12 straight connecting box

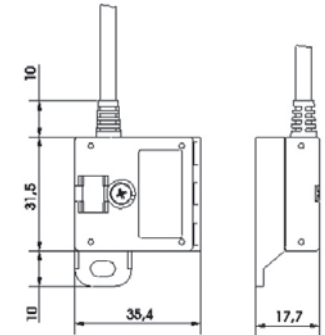

Connecting module



6073900044
AS-i KOPPELMODUL 2M M12W

6073900088
AS-i KOPPELMODUL 1M M12W

- For connecting AS-i devices on AS-i profile cable with an integrated, 2 meters long, ready-made connecting line and M12 angled connecting box
- For connecting AS-i devices on AS-i profile cable with an integrated, 1 meter long, ready-made connecting line and M12 angled connecting box

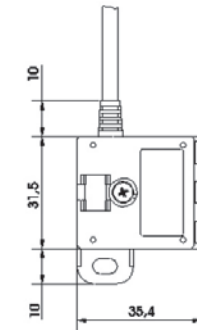

Connecting module + double 1



6073900045
AS-i 2-fach KOPPELMODUL M12G

- For connecting AS-i devices on AS-i and auxiliary power profile cable with an integrated, 2 meters long, ready-made connecting line and M12 straight connecting box

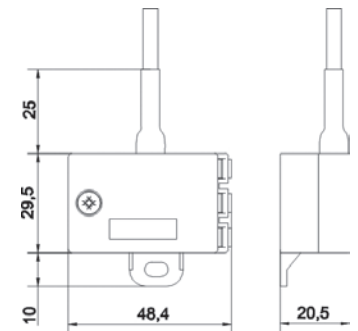

Connecting module + double



6073900046
AS-i 2-fach KOPPELMODUL M12W

- For connecting AS-i devices on AS-i and auxiliary power profile cable with an integrated, 2 meters long, ready-made connecting line and M12 straight connecting box

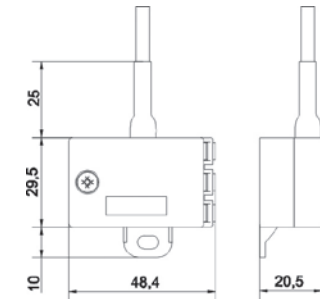

Cable bridge 2



6073900047
AS-i KABELBRÜCKE

- Branch for AS-i profile cable
- The connection under the cables is effected when opening the cover

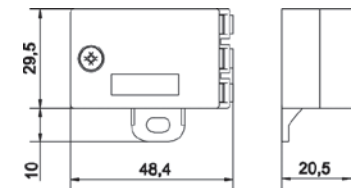

Connecting cable 1



6073900048
AS-i VERBINDUNGSL.M12 1M G/G

- Connecting cable for the connection of the ASi Slave and the connecting module
- Double-sided ready-made straight M12 connecting units (connector/socket)

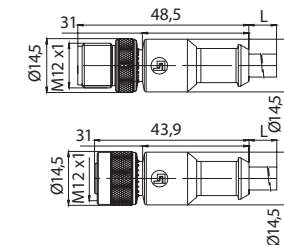

Accessories

Connecting cable



6073900049
AS-i VERBINDUNGSL.M12 1M G/W

- Connecting cable for the connection of the ASi Slave and the connecting module
- Double-sided ready-made M12 connecting units, straight connector/angled socket

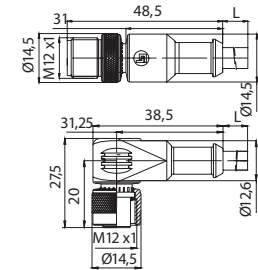

Yellow cable EPDM



6073900040
AS-i KABEL EPDM GELB

- Yellow AS-i profile cable EPDM

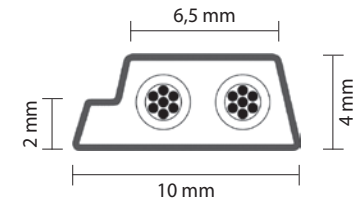

Black cable EPDM



6073900041
AS-i KABEL EPDM SCHWARZ

- Black AS-i profile cable EPDM

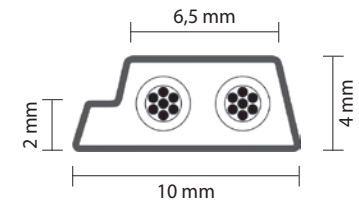



**We make
safety happen.**



**We keep your
visions safe.**

Your contact partners

**International Headquarters
BERNSTEIN AG**
Hans-Bernstein-Str. 1
32457 Porta Westfalica
Phone +49 571 793-0
info@bernstein.eu
www.bernstein.eu

**Denmark
BERNSTEIN A/S**
Phone +45 7020 0522
info.denmark@bernstein.eu
www.bernstein.dk

**Italy
BERNSTEIN S.r.l.**
Phone +39 035 4549037
sales@bernstein.it
www.bernstein.it

**France
BERNSTEIN S.A.R.L.**
Phone +33 1 64 66 32 50
info.france@bernstein.eu
www.bernstein.fr

**Austria
BERNSTEIN GmbH**
Phone +43 2256 62070-0
office@bernstein.at
www.bernstein.at

**United Kingdom
BERNSTEIN Ltd**
Phone +44 1922 744999
sales@bernstein-ltd.co.uk
www.bernstein-ltd.co.uk

**Switzerland
BERNSTEIN (Schweiz) AG**
Phone +41 44 775 71-71
info.schweiz@bernstein.eu
www.bernstein-schweiz.ch

**China
BERNSTEIN Safe Solutions
(Taicang) Co., Ltd.**
Phone +86 512 81608180
info@bernstein-safesolutions.cn
www.bernstein-safesolutions.cn