



**We make
safety happen.**



Position switches and sensors

With certainty. Just the right thing.

CONTENTS

Our products – Your solutions

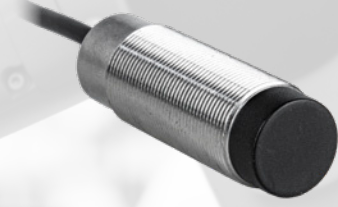

POSITION SWITCHES

- 10 General Information
- 14 Plastic enclosures
- 64 Metal enclosures
- 99 Accessories

POSITION SENSORS

- 100 General Information
- 110 Inductive sensors
- 156 Capacitive sensors
- 170 Magnetic sensors
- 208 Accessories

“Whatever you need ...” — Please contact us

We can offer all of our switches, sensors and enclosures in a customer-specific design. So do not hesitate to contact us. We are always happy to advise you.

Tel +49 571 793-0 | Fax +49 571 793-555
info@bernstein.eu | www.bernstein.eu



BERNSTEIN

Company profile

Successful for more than 75 years

Technically innovative. Personally specific.

Hans Bernstein founded “BERNSTEIN Spezialfabrik für Schaltkontakte” at the foot of the Emperor William Monument in the town of Porta Westfalica, Germany, in 1947. Today, the East Westphalian BERNSTEIN AG company has more than 500 employees in 10 countries and is an international, family-owned business that is now being run by the third generation.

As a worldwide leading manufacturer of industrial safety switchgear and enclosures, BERNSTEIN combines these competencies in two distinct business areas - DETECT and PROTECT. The PROTECT area comprises our enclosure technology, the DETECT area comprises our switch and safety technology.

Customer-specific solutions are part of BERNSTEIN's core strengths. We realise them, starting from the idea, through to consultation, development, processing and implementation, all from one source. This is a service which distinguishes us from other competitors and enables our customers to take a decisive step forward.

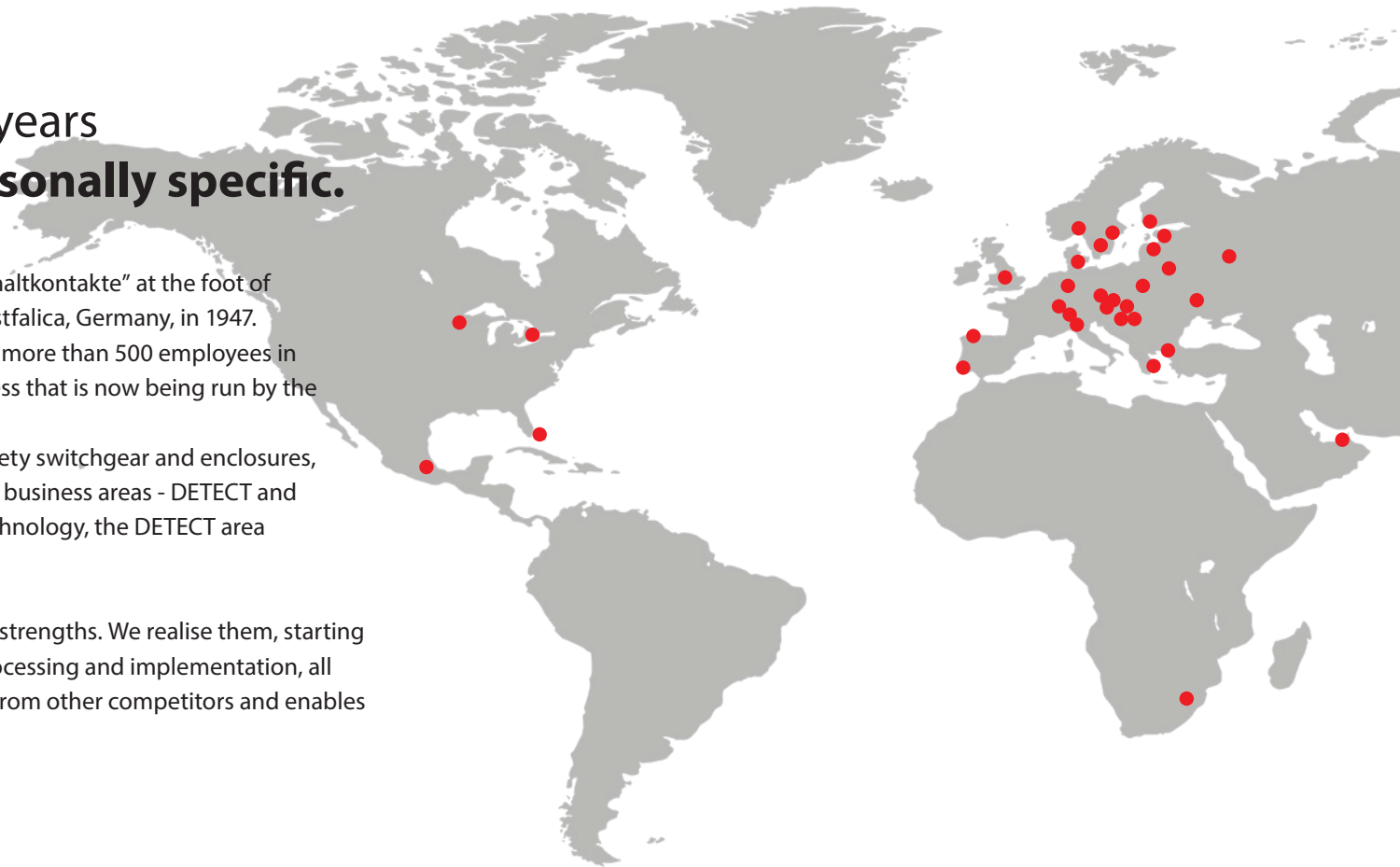



“Over the years, I experienced not only the creation of various new switch series changes in our manufacturing technology, but also some very significant ones. Our fully automatic manufacturing line for the C14 switch insert is state of the art technology – an important milestone for us in the BERNSTEIN factory in Hartum.”

— **Bernd Borchering** | Production Manager, BERNSTEIN AG

A real milestone.



1947
2016

COMPANY FOUNDED
by Hans Bernstein in
Porta Westfalica

IN62, IN65 AND I81
supplement the product
range of our position
switches

36
3

DISTRIBUTORS
are act worldwide
ensuring first class
customer support

GENERATIONS
characterize this
successful family
business

POSITION SWITCHES



POSITION SWITCHES | Plastic enclosure

- 14 C2
- 20 Ti2
- 26 I49
- 32 Bi2
- 36 IN62, IN65, I81
- 52 IN73



POSITION SWITCHES | Metal enclosure

- 64 M49
- 70 MN78
- 82 GC
- 90 SN2
- 94 D
- 99 ACCESSORIES



POSITION SWITCHES

Common features of electromechanical switches

Switching systems

Switching elements lie at the heart of all electro-mechanical switching devices and must correspond to the respective application. Essentially there are two basic types of switching system that differ in terms of their mechanical design and consequently their scope of application:

- Slow-action contacts
- Snap-action contacts

Slow-action contacts

- On actuation, the normally-closed and normally-open contact functions correspond to the movement of the impact pin
- The approach speed controls the contact opening (closing) time
- Large distance / actuating travel between normally-closed and normally-open contact function
- The switching points are identical in both forward and reverse travel

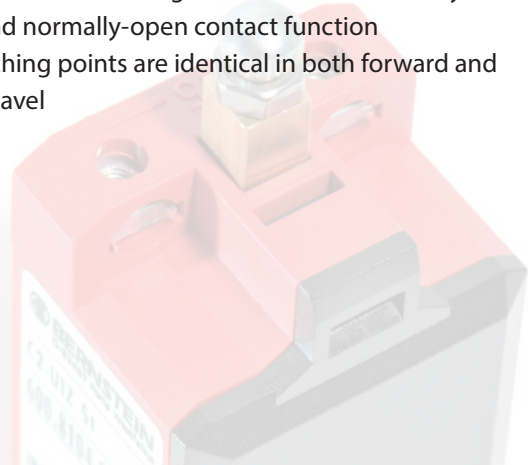

Snap-action contact

- On actuation, the normally-closed contact function is immediately followed by the normally-open contact function
- In this configuration there is no overlap of the NC/NO contacts. The switch provides a distinct OR-function.
- The changeover accuracy is not dependent on the approach speed
- Consistently effective suppression of the DC arc
- Reliable contact-making also for extremely slow approach speeds
- The snap mechanism triggers the full opening width of the contact on reaching the changeover point
- Due to the force reversal in the mechanical system, a different switching point occurs in both the forward and reverse travel. The lag is referred to as hysteresis.

Overlap

The switching principle of snap-action contacts makes overlapping of the NC/NO contact function possible. The term overlap refers to the area, in which both the normally-closed contact as well as the normally-open contact are closed in connection with a changeover switch with a delay.

Switching diagram

The switching diagram describes the function of the switching device in detail.

It combines the mechanical input variables that act on the contact system via the actuator with the electrical output variables. The user can deduce the following information from the switching diagram:

- Mechanical input variables (force, travel, torque, angle)
- Electrical contact-making in both forward and reverse travel
- Terminal designation
- Point at which positive opening is achieved
- Type of contact system

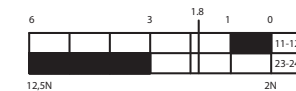

Slow-action contact

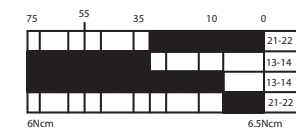

Snap-action contact

- Contact closed
- Contact open

Contact designation

In accordance with DIN 50013 and DIN 50005, the terminal designations of the contact elements always consist of two digits.

The contact rows are numbered consecutively with the allocating digit (1st digit) in the actuation direction. Contacts of a switching element that belong together have the same allocating digit.

The second digit is the function digit that denotes the type of contact element.

- 1 – 2 Normally-closed contact
- 3 – 4 Normally-open contact
- 5 – 6 Normally-closed contact with delayed opening
- 7 – 8 Normally-open contact with delayed closing

Protection class

The protection class of an enclosed device denotes the degree of protection. The degree of protection includes the protection of persons against contact with parts under voltage and the protection of equipment against the infiltration of foreign bodies and water.

BERNSTEIN standard enclosures mainly correspond to protection classes IP65 and IP67. Higher protection ratings are also available for individual customer solutions. In accordance with DIN EN 60521 (IEC 529), the numerals used in the protection rating denote the following:

- 1st digit: Degree of protection against contact and infiltration of foreign bodies
- 2nd digit: Degree of protection against the infiltration of water

Example IP65:

- 6 =** • Complete protection against contact with components under voltage or with internal moving parts
- Protection against dust infiltration
- 5 =** • A water jet directed from all directions at the device must not cause any damaging effects
- Protection against hose water

Designation

The designation of BERNSTEIN switching devices depends on:

- The enclosure designation of the switching device
- The switching function
- The type of actuator

Example:

IN65 → Enclosure designation

U1Z → Switching function

AHK → Actuator

Enclosures

Position switches are supplied in either a plastic enclosure or a metal enclosure. The material selected for a specific application depends on the ambient conditions, the location, and several other factors.

Plastic position switches provide protective insulation and are resistant to many aggressive chemicals and liquids.

The formation of condensation water in moist environments with extreme temperature fluctuations is significantly reduced on plastic enclosures.

Metal-enclosed position switches are able to withstand high mechanical loads and they can also be used wherever hot metal chips and sparks occur, as well as being resistant to many solvents and detergents.

POSITION SWITCHES

Common features of electromechanical switches

Designations – Switching systems

The designations of the switching systems are identical for both plastic and metal switches. The positive opening point is indicated in the technical data sheets by the international symbol \ominus .

Switching function:

NC = Normally-closed contact
NO = Normally-open contact

U1Z

Slow-action contact, 1NC, 1NO

UV1Z

Slow-action contact with overlapping contacts, 1NC, 1NO

UV15Z

Slow-action contact with overlapping contacts, 2NC, 1NO

UV16Z

Slow-action contact with overlapping contacts, 1NC, 2NO

SU1Z

Snap-action contact, 1NC, 1NO

SU2Z

Snap-action contact, 2NC, 2NO

A1Z

Slow-action contact, 1NC

A2Z

Slow-action contact, 2NC

A3Z

Slow-action contact, 3NC

E1

Slow-action contact, 1NO

E2

Slow-action contact, 2NO

40

Slow-action contact, 4NC

04

Slow-action contact, 4NO

31

Slow-action contact, 3NC, 2S

13

Slow-action contact, 1NC, 3NO

22

Slow-action contact, 2NC, 2NO

Safety switches

The scope of application for position switches has changed over time. Whereas position switches were previously used for the purpose of detecting end positions, today they are increasingly assuming functions designed to protect persons and products in machine, equipment and plant construction.

The BERNSTEIN range of safety switches offers the right solution for the most diverse applications in many branches of industry. And when it comes to safety, users particularly appreciate the fact that they are able to procure and receive all the required safety switches and professional advice from one source.

The decisive factors governing the selection of safety equipment include the ambient conditions, the installation situation and a risk analysis.

A position switch that can be used for safety functions is identified by the standardised symbol \ominus conforming to EN 60947-5-1 Addendum K.

The switches can, of course, also be used for pure position monitoring purposes.

Safety switches are divided into two categories, Type 1 and Type 2.

The difference is in the actuating elements which are completely integrated in the enclosure in Type 1 and separated from the switching element in Type 2.

⊕ = Mechanical positive opening action

The term positive opening action refers to the contact separation as the direct result of a defined movement of the switch actuator by means of non-sprung parts. All parts involved in contact separation must be form-fit connected.

The positive opening distance describes the minimum travel distance from the start of the actuation of the operating element up to the point where the positive opening action of the opening contacts is completed.

DIN EN 60947-5-1 defines two types of positive opening action contacts with 4 connections and double break:

Type Za

- Positively opening contacts not galvanically isolated

Type Zb

- Positively opening contacts galvanically isolated

Galvanic isolation describes the isolation of electrically conducted parts by insulating material or by air gaps.

In switching devices with several contact elements, galvanically isolated contact elements make it possible to switch voltages with different potentials (e.g. a normally-closed contact in a safety circuit, normally-open contact for an indicator).

In accordance with applicable health and safety requirements, protective devices (guards) must be mounted on machines, devices and systems that perform hazardous movements. Safety switches in the form of electromechanical switching devices are predominantly used for this purpose as they offer the following advantages:

- High degree of safety
- Non-susceptibility to interference
- Safety status easily checked on site
- Rational solutions

Form-fit, mechanical drives or coupling elements in the form of levers, rods, gearwheels etc. are necessary to ensure the optimum operation of these safety components.

Switching devices that are used for safety functions must be identified with the symbol ⊕ internationally standardised in accordance with DIN EN 60947-5-1. In defining the class of switching devices, this symbol

denotes two important properties that must be met for personal protection applications:

- Mechanical positive opening action
- Disruptive breakdown voltage > 2,5 kV

Disruptive breakdown voltage

In accordance with DIN EN 60947-5-1, open contacts must be able to maintain a minimum surge voltage of 2.5 kV without any disruptive breakdown.



Plastic enclosures

Position switches Plastic C2



Product characteristics

- Very small dimensions
- 2 positive break contacts
- Front- and top mounting
- Different actuators

Good to know ...

The C2 position switch has the smallest possible dimensions and is therefore perfect for applications in very confined spaces.

The two contacts are positive break ones. It can therefore be used in safety applications.

Technical design

- Slow- and snap action
- **Versions:** 1 NC/1 NO, 2 NC, 2 NO

Technical data

Electrical data		
Design insulation voltage	U_i max.	250 V AC
Conventional thermoelectric current	I_{the}	10 A
Rated operating voltage	U_e max.	240 V
Utilisation category	U_e/I_e	AC-15, U_e/I_e 240 V/3 A
Short-circuit protection		Safety fuse 6 A gL/gG
Protection class		II, protective insulation
Mechanical data		
Enclosure material		Thermoplastics, glass-fibre reinforced (UL 94-V0)
Ambient temperature		-30 °C to +80 °C
Mechanical lifetime		3×10^6 switching cycles
B10d		6 million
Switching frequency		≤ 100 /min
Type of connection		Screwed connections (M3.5)
Conductor cross-sections		Single-wire 0.5 – 1.5 mm ² or strand with wire-end ferrule 0.5 – 1.5 mm ²
Cable entry		Rectangle 8.5 × 3.5 mm
Protection class		IP20 conforming to EN 60529; DIN VDE 0470 T1
Standards		
VDE 0660 T100, DIN EN 60947-1, IEC 60947-1		
VDE 0660 T200, DIN EN 60947-5-1, IEC 60947-5-1		

Mounting

Front- and top mounting (type-related)

- a) 2 × round holes for M4 screws
- b) 2 × insert nuts for front-side installation for M3 screws M3 (type-related)

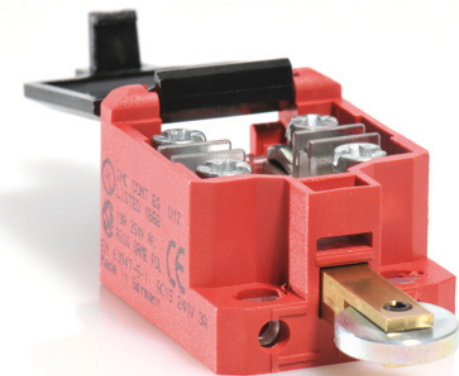
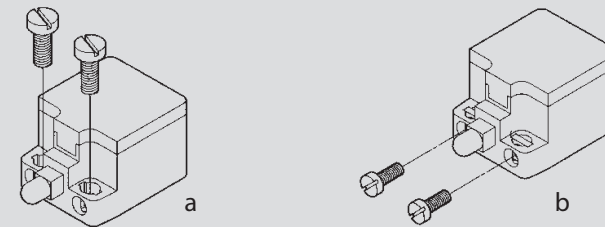

POSITION SWITCHES PLASTIC C2

C2-... W

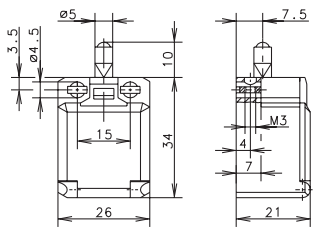

	1 NC / 1 NO	2 NC	2 NO
--	-------------	------	------

Slow-action system

6008101001
C2-U1Z

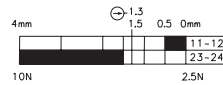

6008801003
C2-A2Z

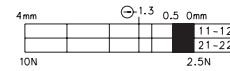

6008801005
C2-E2

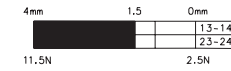

Snap-action system

6008351002
C2-SU1Z

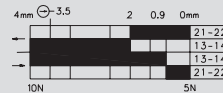

6008851004
C2-SA2Z

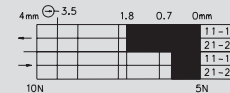

6008851006
C2-SE2

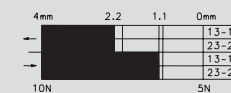

Special features: on request

C2-... ST

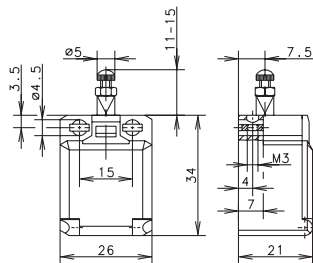

	1 NC / 1 NO	2 NC	2 NO
--	-------------	------	------

Slow-action system

6008104025
C2-U1Z ST

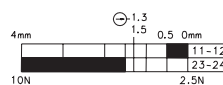

6008804027
C2-A2Z ST

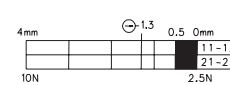

6008804029
C2-E2 ST

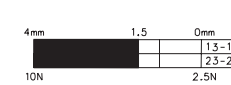

Snap-action system

6008354026
C2-SU1Z ST



Special feature: Actuator length adjustable with adjusting screw



C2... K

	1 NC / 1 NO	2 NC
--	--------------------	-------------

Slow-action system

6008107019
C2-U1Z K

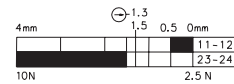

6008807021
C2-A2Z K

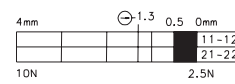

Snap-action system

6008357020
C2-SU1Z K

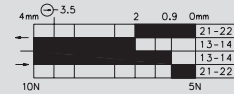

6008857022
C2-SA2Z K

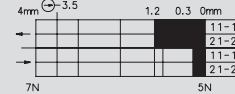

Special feature: Button actuator, for manual operation

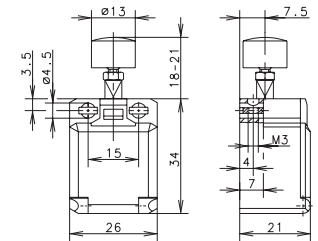

C2... R

	1 NC / 1 NO	2 NC	2 NO
--	--------------------	-------------	-------------

Slow-action system

6008116013
C2-U1Z R

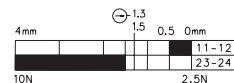

6008816015
C2-A2Z R

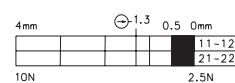

6008816017
C2-E2 R



Snap-action system

6008366014
C2-SU1Z R

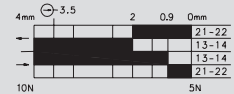

6008866016
C2-SA2Z R

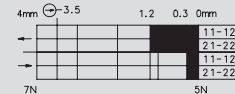

Special feature: on request, also available with the roller turned by 90°

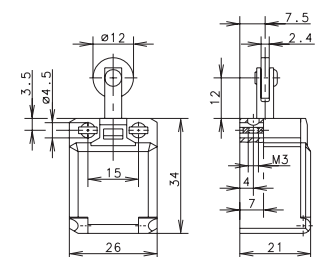

POSITION SWITCHES PLASTIC C2

C2-... O.M.

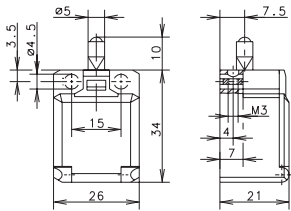

	1 NC / 1 NO	2 NC
--	-------------	------

Slow-action system

6008101007
C2-U1Z O.M.

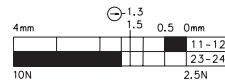

6008801009
C2-A2Z O.M.

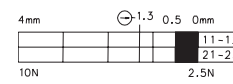

Snap-action system

6008351008
C2-SU1Z O.M.

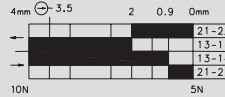

Special features: on request

C2-... BISTABIL O.M.

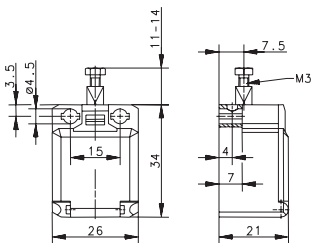

	1 NC / 1 NO
--	-------------

Snap-action system

6108351008
C2-SU1Z BISTABIL O.M.

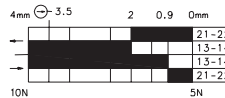

Special features: bistable characteristics, the actuator must be returned to the initial position by external actuation (pulling); actuator length adjustable with M3 adjusting screw



Notes

Diagrams. Sketches. Ideas.

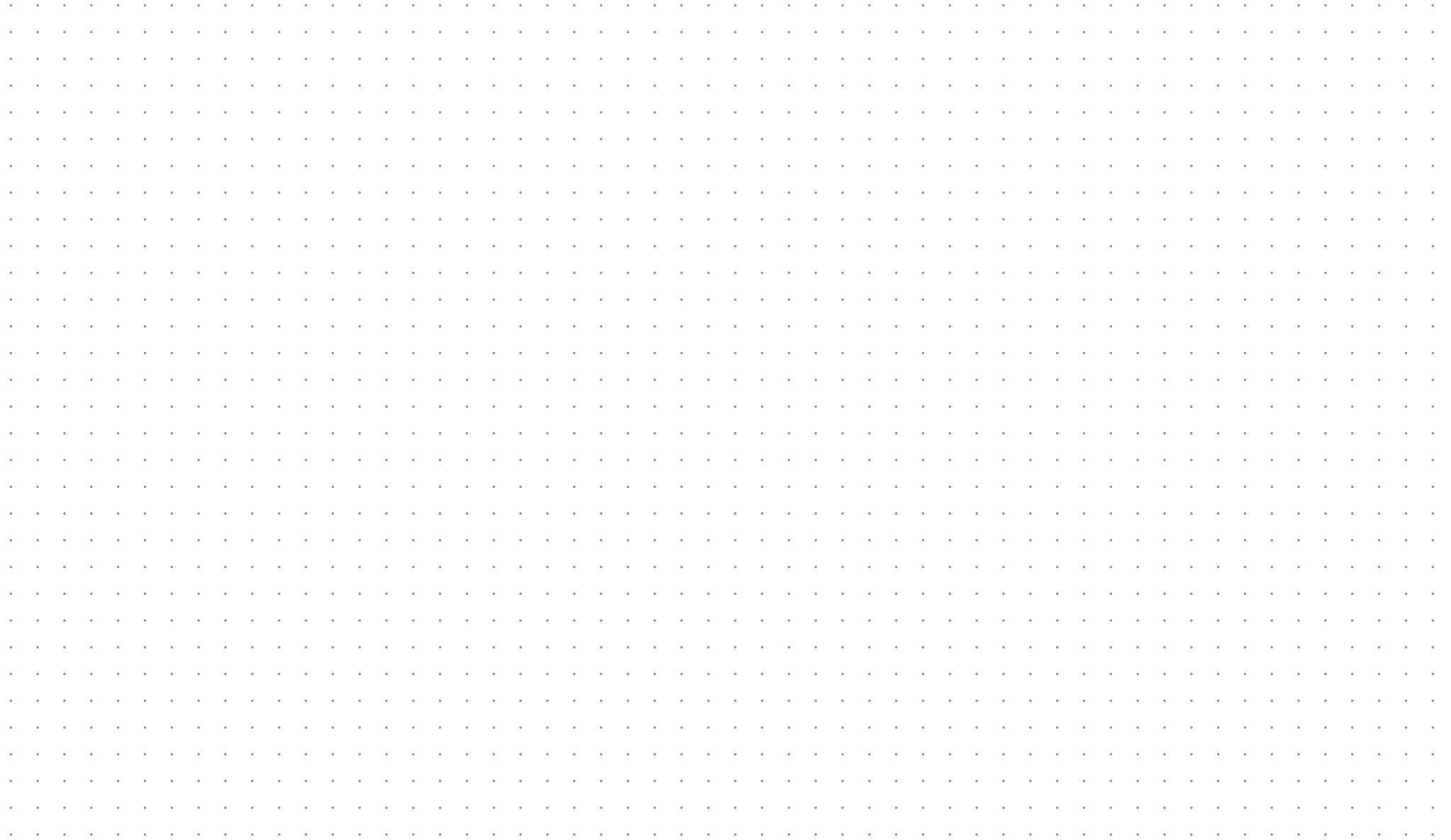

Plastic enclosures

Position switches Plastic Ti2



Product characteristics

- Compact dimensions
- 2 contacts, 1 or 2 positive break contacts
- Protection class IP65
- Different actuators
- Snap-on cover can be released with a screwdriver

Good to know ...

With a higher protection class (IP65) and a wider range of actuators such as the C2, the Ti2 is suitable for many different applications.

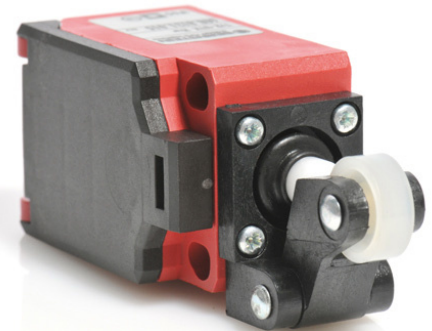

Technical design

- Slow- and snap action
- **Versions:** 1 NC/1 NO, 2 NC, 2 NO

Technical data

Electrical data		
Design insulation voltage	U_i max.	240 V AC
Conventional thermoelectric current	I_{the}	10 A
Rated operating voltage	U_e max.	240 V
Utilisation category	U_e/I_e	AC-15, U_e/I_e 240 V/3 A; DC-13, U_e/I_e 240 V/0.27 A
Short-circuit protection		Safety fuse 6 A gL/gG
Protection class		II, protective insulation
Mechanical data		
Enclosure material		Thermoplastics, glass-fibre reinforced (UL 94-V0)
Ambient temperature		-30 °C to +80 °C
Mechanical lifetime		3×10^6 switching cycles
B10d		6 million
Switching frequency		≤ 100 /min.
Type of connection		Screwed terminals
Conductor cross-sections		Single-wire 0.5 – 1.5 mm ² or strand with wireend ferrule 0.5 – 1.5 mm ²
Cable entry		1 x M16 x 1.5
Protection class		IP65 conforming to EN 60529; DIN VDE 0470 T1
Standards		
VDE 0660 T100, DIN EN 60947-1, IEC 60947-1VDE		
0660 T200, DIN EN 60947-5-1, IEC 60947-5-1		

Options

- Available with M12 connectors
- Customised cables and connectors upon request

Mounting

- Mounting dimension according to DIN EN 50047
- 2 oval holes for adjustment for screws M4 (distance 22 mm)
- Fixed positioning for safety applications with two M5 screws (distance 23 mm)

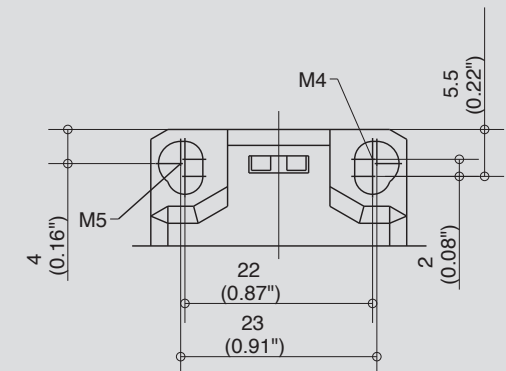
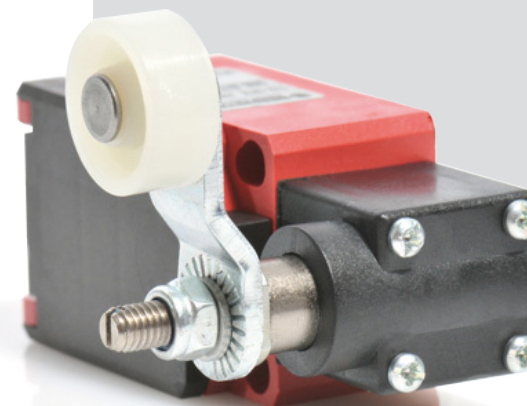

POSITION SWITCHES PLASTIC Ti2

Ti2-... W

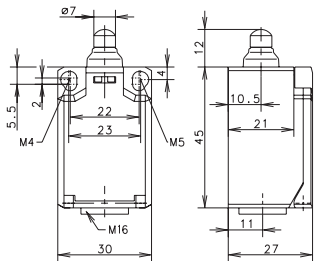

	1 NC / 1 NO	2 NC	2 NO
--	-------------	------	------

Slow-action system

6088103001
Ti2-U1Z W

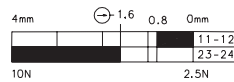

6088803003
Ti2-A2Z W

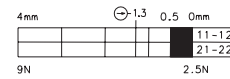

6088803005
Ti2-E2 W



Snap-action system

6088153002
Ti2-SU1Z W

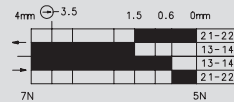

6088853004
Ti2-SA2Z W



Special feature (on request): available with increased switching force

Ti2-... RIW

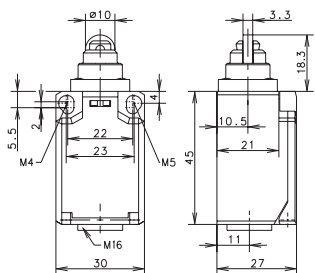

	1 NC / 1 NO	2 NC	2 NO
--	-------------	------	------

Slow-action system

6088117007
Ti2-U1Z RIW

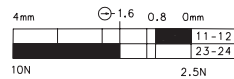

6088817009
Ti2-A2Z RIW

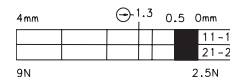

Snap-action system

6088167008
Ti2-SU1Z RIW

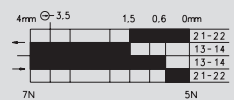

6088867010
Ti2-SA2Z RIW

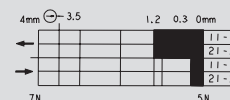

6088867012
Ti2-SE2 RIW

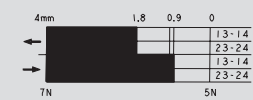

Special features (on request): available with increased switching force; available with different actuating directions; cannot be turned by user



Replacement actuator: 3918190681

Ti2-... HW

	1 NC / 1 NO	2 NC	2 NO
Slow-action system	6088121015 Ti2-U1Z HW 	6088821017 Ti2-A2Z HW 	6088871020 Ti2-SE2 HW
Snap-action system	6088171016 Ti2-SU1Z HW 	6088871018 Ti2-SA2Z HW 	

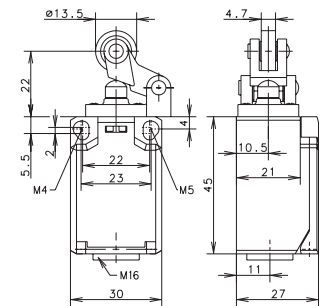

Special features (on request): available with different actuating directions; with steel roller; various roller diameters



Replacement actuator: 3918351166

Ti2-... AH

	1 NC / 1 NO	2 NC
Slow-action system	6088135021 Ti2-U1Z AH 	6088835023 Ti2-A2Z AH
Snap-action system	6088185022 Ti2-SU1Z AH 	6088885024 Ti2-SA2Z AH

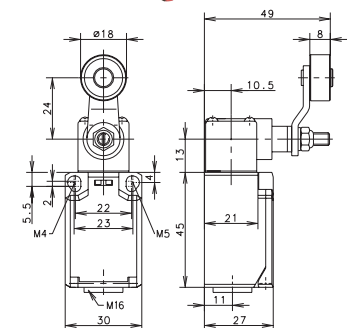

Special features (on request): available with different actuating directions; with a steel roller; various roller diameters; cranked or straight lever; various lever lengths; with a roller over switch

POSITION SWITCHES PLASTIC Ti2

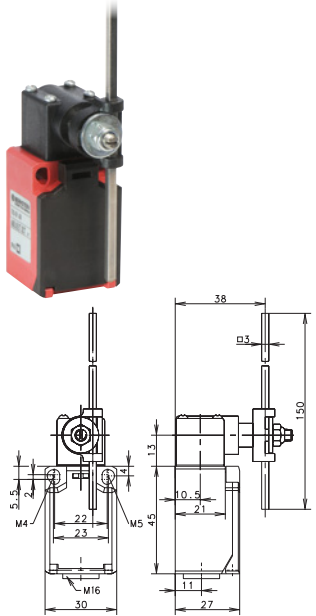

Ti2-... AD

Replacement actuator: 3918370986



	1 NC / 1 NO	2 NC
Slow-action system	6088137027 Ti2-U1 AD 65° 34° 22° 0° 14Ncm 3.5Ncm	6088837029 Ti2-A2 AD 65° 22° 0° 12.5Ncm 3.5Ncm
Snap-action system	6088187028 Ti2-SU1 AD 65° 34° 23° 0° 10Ncm 7Ncm	6088887030 Ti2-SA2 AD ⊖ 60° 65° 31° 14° 0° 10Ncm 7Ncm

Special features (on request): available with increased switching force; available with different actuating directions; with various actuator lengths

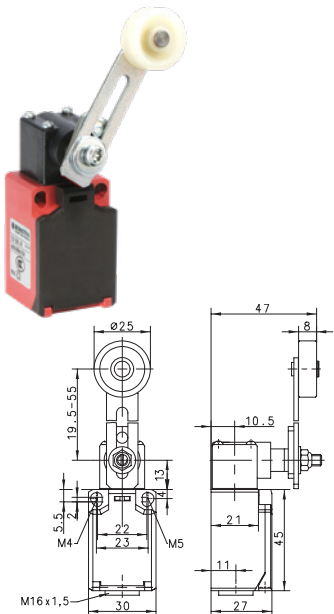

Ti2-... AV

Replacement actuator: 3918360984



	1 NC / 1 NO	2 NC	2 NO
Slow-action system	6088136033 Ti2-U1 AV 65° 34° 22° 0° 14Ncm 3.5Ncm		
Snap-action system	6088186034 Ti2-SU1 AV 65° 34° 23° 0° 10Ncm 7Ncm	6088886036 Ti2-SA2 AV ⊖ 60° 65° 31° 14° 0° 10Ncm 7Ncm	6088886038 Ti2-SE2 AV 65° 38° 27° 0° 10Ncm 7Ncm

Special features (on request): available with different actuating directions; various roller diameters; various lever lengths; with roller over switch

Notes

Diagrams. Sketches. Ideas.

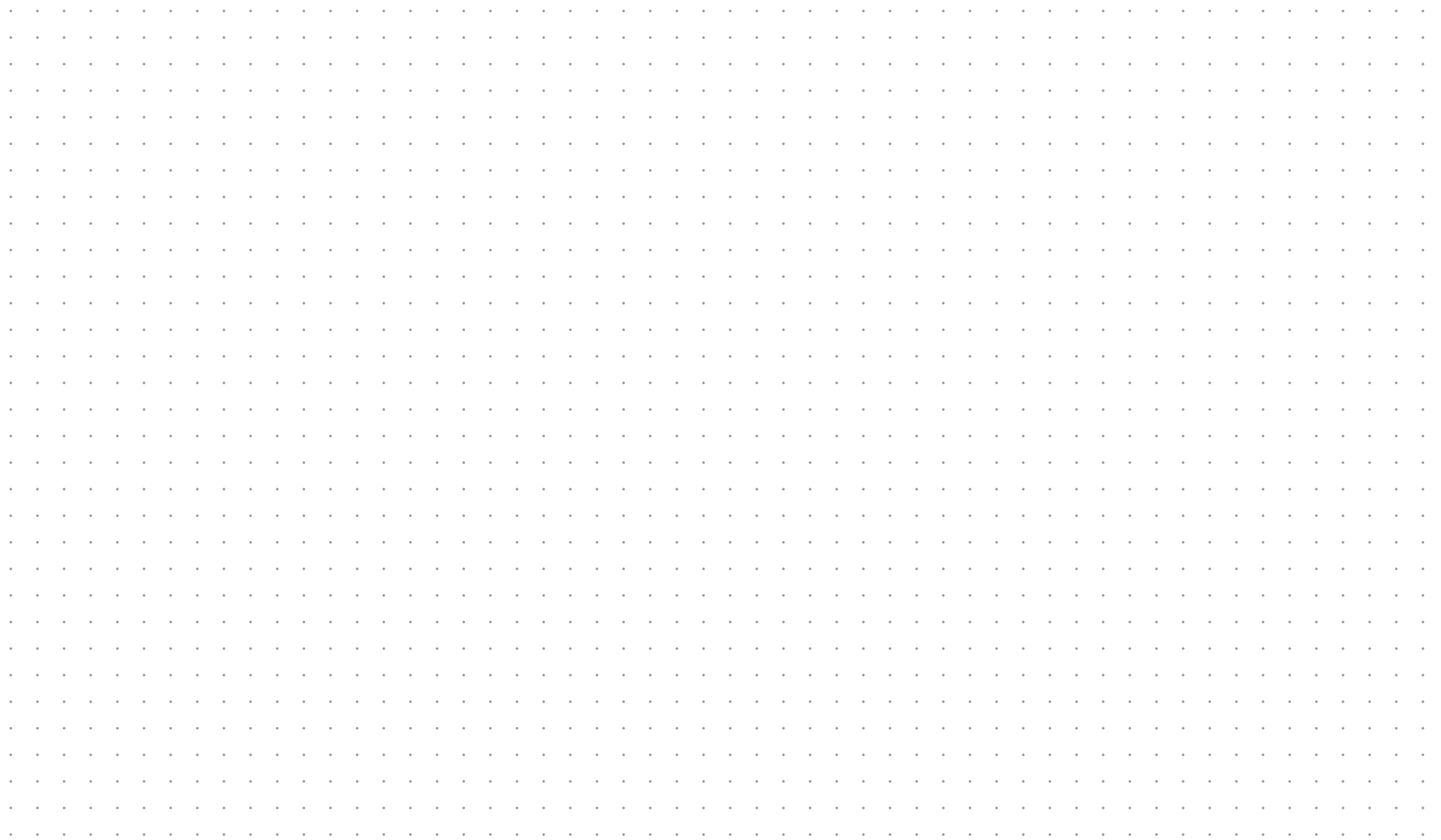

Plastic enclosures

Position switches Plastic I49



Product characteristics

- Flat and compact design
- Pre-installed connecting cable (1m length) for quick and easy installation
- Top-mounting versions available
- Cable outlet on the side or at the bottom
- High protection class IP67
- Suitable for safety applications according to DIN EN 60947-5-1 (positive break)

Good to know ...

Due to the space-saving enclosures and the high protection class IP67 the position switches of the I49 series are perfect for an installation where a flat design and a high protection class of IP67 is required. The switches are often used for the monitoring of covers and inspection doors, for position monitoring applications and similar applications.

The high protection class allows outdoor applications.

Options

- Different cable lengths are available on request

Technical design

- Slow- and snap action
- **Versions:** 1 NC/1 NO, 2 NC, 2 NC/2 NO

Technical data

Electrical data

Design insulation voltage	U_i max.	400 V AC
Conventional thermoelectric current	I_{the}	10 A
Rated operating voltage	U_e max.	240 V
Utilisation category		AC-15; 24 V / 10 A; 240 V / 3 A
Protection class		II, protective insulation

Mechanical data

Ambient temperature		-25 °C to +70 °C (connecting cable firmly wired)
Mechanical lifetime		10 x 10 ⁶ switching cycles
Switching frequency		≤ 60/min.
Type of connection		Cable 4 x 0.75 mm ²
Protection class		IP67 conforming to IEC/EN 60529

Standards

VDE 0660 T100, DIN EN 60947-1, IEC 60947-1
 VDE 0660 T200, DIN EN 60947-5-1, IEC 60947-5-1

Application examples

- Monitoring of safety gates, hatches or protective hoods
- Position monitoring of moving parts
- Object detection in conveying technology
- End position control of components
- Position monitoring on rolling doors
- Monitoring of sliding doors



POSITION SWITCHES PLASTIC I49



I49-... IW

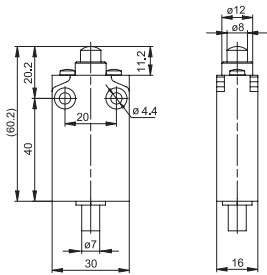

	1 NC / 1 NO Snap-action	1 NC / 1 NO Slow-action	2 NC Slow-action	2 NC / 2 NO Slow-action
Switching diagram				
Cable outlet right	6089152048 I49-SU1Z IW	6089102049 I49-U1Z IW		
Cable outlet below	6089152058 I49-SU1Z IW Z	6089102059 I49-U1Z IW Z	6089802070 I49-A2Z IW Z	6089202075 I49-U2Z IW Z

I49-... AH

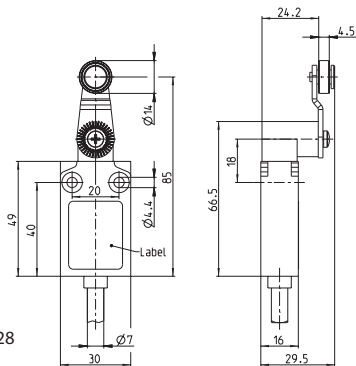

	1 NC / 1 NO Snap-action	1 NC / 1 NO Slow-action	2 NC Slow-action	2 NC / 2 NO Slow-action
Switching diagram				
Cable outlet right	6089185056 I49-SU1Z AH	6089135057 I49-U1Z AH		
Cable outlet below	6089185066 I49-SU1Z AH Z	6089135067 I49-U1Z AH Z	6089835073 I49-A2Z AH Z	6089235078 I49-U2Z AH Z



I49-... RIW

	1 NC / 1 NO Snap-action	1 NC / 1 NO Slow-action	2 NC Slow-action	2 NC / 2 NO Slow-action
Switching diagram				
Cable outlet right	6089167052 I49-SU1Z RIW	6089117053 I49-U1Z RIW		
Cable outlet below	6089167060 I49-SU1Z RIW Z	6089117061 I49-U1Z RIW Z	6089817071 I49-A2Z RIW Z	6089217076 I49-U2Z RIW Z

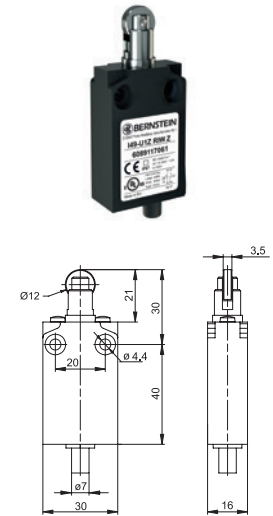

I49-... IWF

	1 NC / 1 NO Snap-action	1 NC / 1 NO Slow-action	2 NC Slow-action	2 NC / 2 NO Slow-action
Switching diagram				
Cable outlet right	6089152050 I49-SU1Z IWF	6089102051 I49-U1Z IWF		
Cable outlet below	6089152062 I49-SU1Z IWF Z	6089102063 I49-U1Z IWF Z	6089852069 I49-A2Z IWF Z	6089452074 I49-U2Z IWF Z

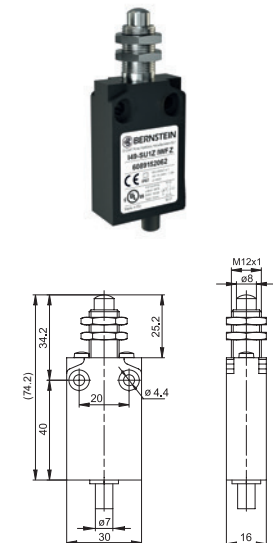

POSITION SWITCHES PLASTIC I49



I49-... RIWF

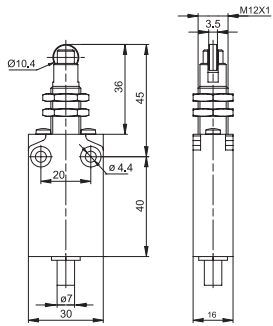

	1 NC / 1 NO Snap-action	1 NC / 1 NO Slow-action	2 NC Slow-action	2 NC / 2 NO Slow-action
Switching diagram				
Cable outlet right	6089167054 I49-SU1Z RIWF	6089117055 I49-U1Z RIWF		
Cable outlet below	6089167064 I49-SU1Z RIWF Z	6089117065 I49-U1Z RIWF Z	6089817072 I49-A2Z RIWF Z	6089217077 I49-U2Z RIWF Z



Plastic enclosures

Position switches Plastic Bi2



Product characteristics

- Protection class IP65 according to VDE 0470 T1
- Enclosure and cover PA 6, self-extinguishing (UL-94 V0)
- Actuator turnable by 4 x 90°
- Cable entry 2 x M16 x 1.5
- Connection designation conforming to DIN EN 50013

Good to know ...

Due to its two cable entry slots, this switch is ideally suited for the connection of two cables. A large number of actuators are available. Please do not hesitate to contact us for support in choosing the best solution for your application.

Options

- Available with M12 plug
- Preassembled with customer-specific cables and connectors on request

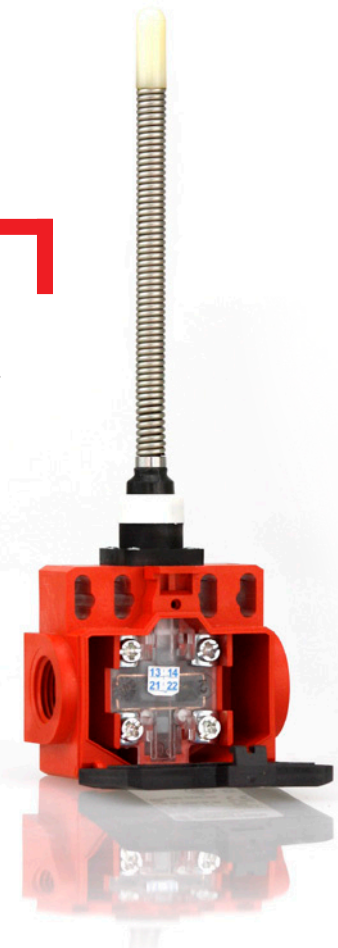

Technical design

- Slow- and snap action
- **Versions:** 1 NC/1 NO, 2 NC

Technical data

Electrical data		
Design insulation voltage	U_i max.	400 V AC
Conventional thermoelectric current ^①	I_{the}	10 A
Rated operating voltage	U_e max.	240 V AC
Utilisation category		AC15, U_e/I_e 240 V/3 A
Short-circuit protection (up to) ^①		Safety fuse 10 A gL/gG
Protection class		II, protective insulation
Mechanical data		
Enclosure material		Thermoplastics, glass-fibre reinforced
Ambient temperature		-30 °C to +80 °C
Mechanical lifetime (up to) ^①		10 x 10 ⁶ switching cycles
B10d (up to) ^①		20 million
Switching frequency		≤ 100/min.
Type of connection		Screwed terminals
Conductor cross-sections		Single-wire 0.5 – 1.5 mm ² or strand with wire-end ferrule 0.5 – 1.5 mm ²
Cable entry		2 x M16 x 1.5
Protection class		IP65 conforming to EN 60529; DIN VDE 0470 T1
Standards		
VDE 0660 T100, DIN EN 60947-1, IEC 60947-1		
VDE 0660 T200, DIN EN 60947-5-1, IEC 60947-5-1		
① Depending on the switching system		

Mounting

- 2 M4 oval holes (distance 22 mm) for adjustment
- 2 M4 oval holes (distance 42 mm) for adjustment
- 2 M5 round holes (distance 21 mm) for security applications
- 2 M5 round holes (distance 41 mm) for safety applications without additional fixation required
- Front mounting

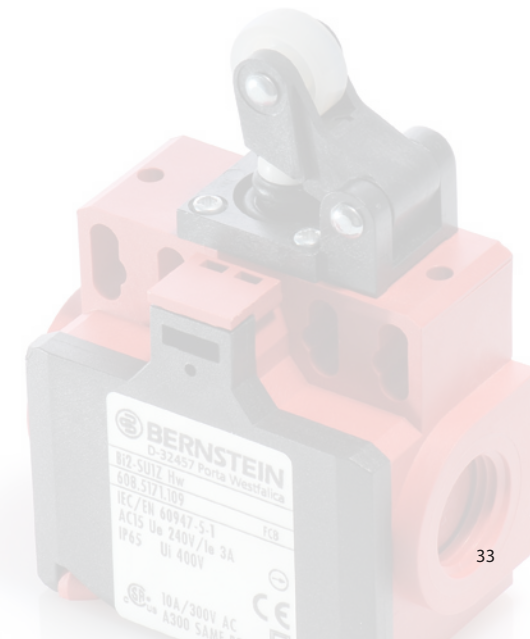
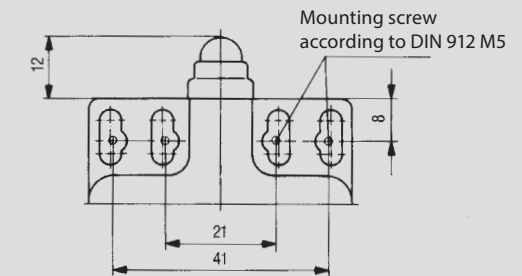

POSITION SWITCHES PLASTIC Bi2

Bi2-... W

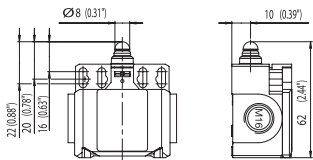

	1 NC / 1 NO	2 NC	1 NC / 1 NO overlapping
Slow-action system	6085103100 Bi2-U1Z W 	6085803116 Bi2-A2Z W 	6085303115 Bi2-UV1Z W
Snap-action system	6085153107 Bi2-SU1Z W 		

Bi2-... RIW

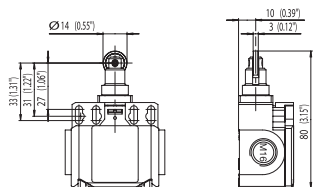

	1 NC / 1 NO	1 NC / 1 NO
Slow-action system	6085117101 Bi2-U1Z RIW 	6085135104 Bi2-U1Z AH
Snap-action system	6085167108 Bi2-SU1Z RIW 	6085185111 Bi2-SU1Z AH

Special feature (on request): with steel roller

Bi2-... AH

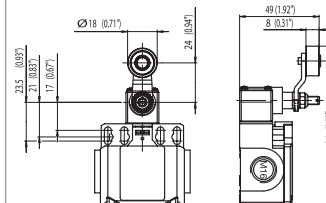

Slow-action system

Snap-action system

Special features (on request): available with different actuating directions; with steel roller; various roller diameters; cranked or straight lever; various lever lengths

Bi2-... AV



1 NC / 1 NO

Slow-action system



Snap-action system

6085186112
Bi2-SU1 AV

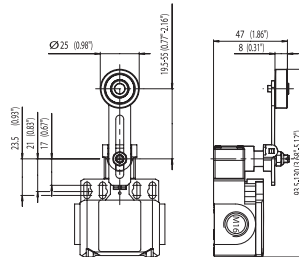
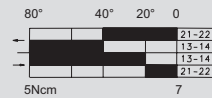

Bi2-... HW RO13.5



1 NC / 1 NO

Slow-action system



Snap-action system

6085171109
Bi2-SU1Z HW RO13.5

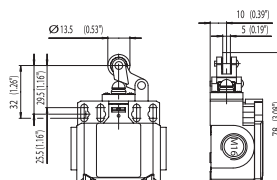
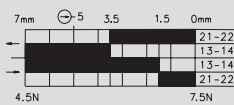

Bi2-... FF



1 NC / 1 NO

Slow-action system

6185140104
Bi2-U1 FF

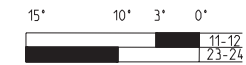

Snap-action system

6085190114
Bi2-SU1 FF



Special features (on request):
available with different spring lengths; spring rod; various spring versions

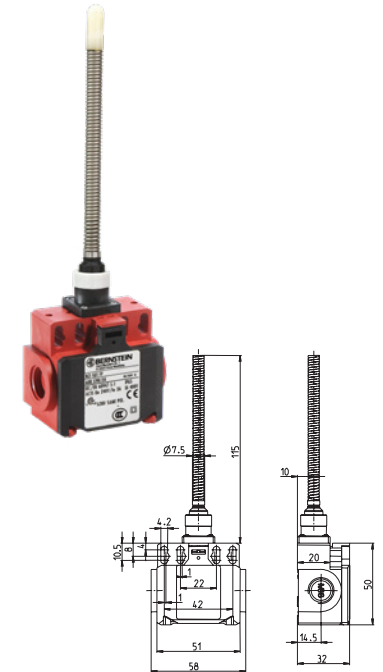

Bi2-... AD



1 NC / 1 NO

Slow-action system

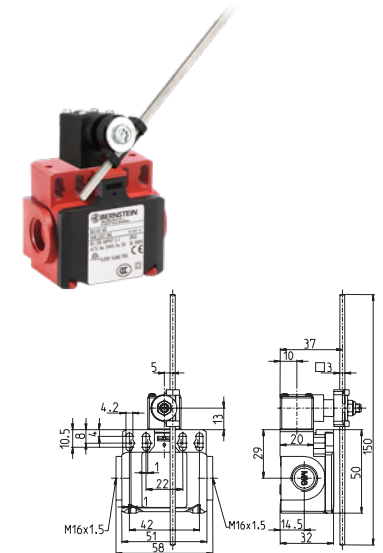

Snap-action system

6085187113
Bi2-SU1 AD



Plastic enclosures

Position switches Plastic IN62, IN65 und I81



Product characteristics

- Highest reliability at low currents (1 mA/24VDC)
- Actuator and parts of the cover made of metal (IN65 and I81)
- Tool-free rotation (8 x 45°) and changing of the actuators (IN65 und I81) is possible without a tool
- Standard switch and standard actuator conforming to DIN EN 50047
- Protection class IP66 und IP67 conforming to EN 60529

Options

- Available with M12 connector
- Cable entry M16 x 1.5

Good to know ...

The new standard switches, IN62 and IN65, and the position switch I81, are the latest in our I88 series. All three switches, i.e. IN62, IN65 and I81, include the integrated, new type C14 switch insert. The C14 has encapsulated contacts that ensure good functioning at very low currents (1 mA / 24 VDC). Due to the modular design and the easy-to-change actuator, they can be used for all applications in mechanical and plant engineering.

The standard IN62 switch is the basic switch. Its actuators can handle many lift and escalator applications.

The standard IN65 switch is the “all-rounder”. It is as effective as a moulded plastic switch, as robust as a metal switch, and clever due to its modular design and the easy-to-change actuator.

The I81 position switch completes the new series of position switches. It is the bistable version of the IN65, our “latching” switch.

What's so special about the C14?

We installed a modern assembly line in our factory in Hille-Hartum to produce the new C14 switch inserts (1 NC/1 NO, 2 NC, 2 NO). The modular design of the line allows maximum flexibility for the production of all the different switch inserts. During the fully-automatic manufacturing process, all switch inserts are tested to ensure the highest quality. More than 800 switch inserts can be produced per hour.

The most important feature of the C14 switch insert is the encapsulated contacts. Production takes place in a cleanroom environment to ensure that the contact surfaces are extremely clean, even during the assembly. And due to the encapsulated enclosure of the C14 switch insert, we can ensure that, even after the manufacturing process, no dirt or dust can contaminate the contacts. The switch can therefore handle very low currents of 1 mA at 24 VDC.



C14 SWITCH INSERT

Technical design

- Slow- and snap action
- **Versions:** 1 NC/1 NO, 2 NC, 2 NO, overlapping contacts

Technical data

Electrical data		
Design insulation voltage	U _i max.	400 V AC
Conventional thermoelectric current	(up to) I _{the}	5 A
Rated operating voltage	U _e max.	240 V AC/24 V DC
Utilisation category (up to)		AC-15, U _e /I _e 240 V/3 A DC-13 U _e /I _e 24 V/1.5 A (B300 Table A.1)
Short-circuit protection (up to)		Safety fuse 4 A gG
Protection class		II, protective insulation
Mechanical data		
Enclosure material		Thermoplastics, glass-fibre reinforced (UL 94-V0)
Ambient temperature		-30 °C to +75 °C
Mechanical lifetime (up to)		30 × 10 ⁶ switching cycles
B10d NC Contact cycles (up to)		30 million
B10d NO Contact cycles (up to)		1 million
Switching frequency		≤ 60/min.
Type of connection		4 screwed connections (M3)
Conductor cross-sections		Single-wire 0.5 – 1.5 mm ² or strand with wire-end ferrule 0.5 – 1.5 mm ²
Cable entry		1 × M20 × 1.5
Protection class		IP66/IP67 according to EN 60529; DIN VDE 0470 T1
Standards		
VDE 0660 T211, DIN EN 60947-5-4, IEC 60947-5-4 DIN EN ISO 13849-1, DIN EN ISO 13849-2		

Mounting

- 2 screws M4 (distance 22 mm), adjustment with oval holes
- 2 screws M5 for safety applications without any additional fixation required



ACTUATORS IN65, I81



Here is a small selection of our actuators. Others are available on request.

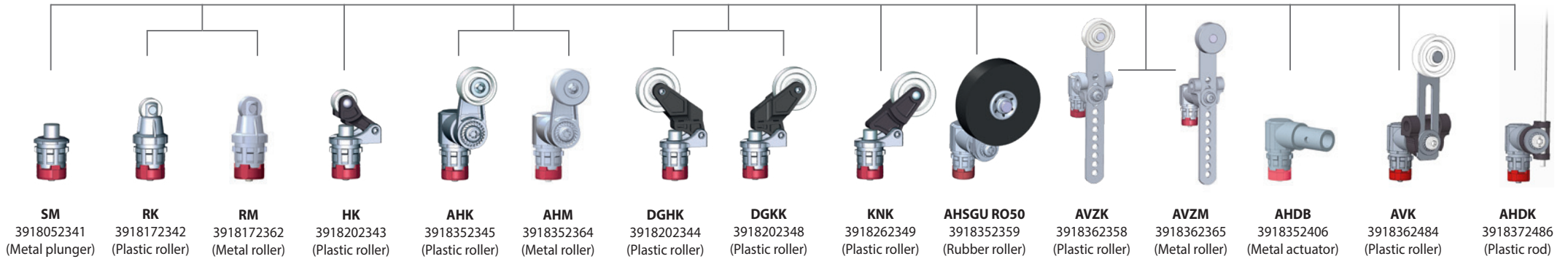

IN65 enclosure with C14 switching unit

	1 NC / 1 NO	2 NC	2 NO	1 NC / 1 NO overlapping
Slow-action system	6083000272 IN65-U1Z M20	6083000274 IN65-A2Z M20	6083000276 IN65-E2 M20	6083000277 IN65-UV1Z M20
Snap-action system	6083000271 IN65-SU1Z M20	6083000273 IN65-SA2Z M20	6083000275 IN65-SE2 M20	



The enclosures are also available in black.

Modular concept

Changing an actuator of our new position switches is very easy, no tools are required: Simply pull the metal clamp to the front, remove the actuator, insert the new actuator and push the metal clamp back — done.

Optional

Our position switches are usually equipped with an M20 thread for cable glands. All switches are also available with M12-connectors.

IN65 enclosure with C14 switching unit and M12 plug connector

	1 NC / 1 NO	2 NC	2 NO	1 NC / 1 NO overlapping
Slow-action system	6083000289 IN65-U1Z M12	6083000290 IN65-A2Z M12	6083000291 IN65-E2 M12	6083000292 IN65-UV1Z M12
Snap-action system	6083000293 IN65-SU1Z M12	6083000294 IN65-SA2Z M12	6083000295 IN65-SE2 M12	

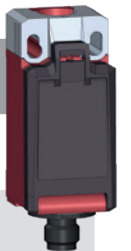

POSITION SWITCHES PLASTIC IN62

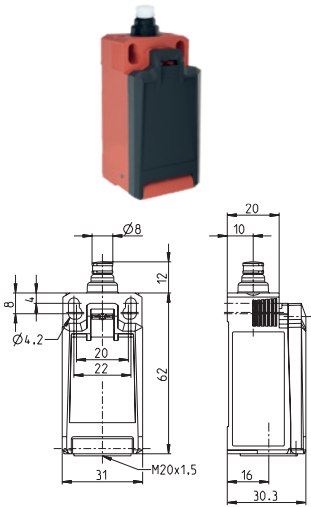

IN62-... SK



	1 NC / 1 NO \rightarrow	2 NC \rightarrow	2 NO \rightarrow	1 NC / 1 NO overlapping \rightarrow
Slow-action system	6083000201 IN62-U1Z SK 5,9 1,8 \ominus 2,5 1,0 0 [mm] 11,5 2,5 [N]	6083000203 IN62-A2Z SK 5,9 1,8 \ominus 1,0 0 [mm] 10,5 1,5 [N]	6083000205 IN62-E2 SK 5,9 2,5 0 [mm] 13 3,5 [N]	6083000206 IN62-UV1Z SK 5,9 3,3 \ominus 2,5 1,5 0 [mm] 12 2,4 [N]
Snap-action system	6083000200 IN62-SU1Z SK 5,9 5,0 \ominus 2,8 1,3 0 [mm] 6,5 7,5 [N]	6083000202 IN62-SA2Z SK 5,3 \ominus 5,9 2,5 1,1 0 [mm] 6,5 7,5 [N]	6083000204 IN62-SE2 SK 5,9 3,0 1,5 0 [mm] 6,5 7,5 [N]	

IN62-... FF

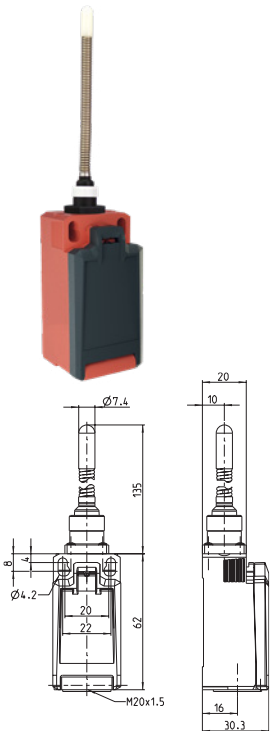

	1 NC / 1 NO \rightarrow	2 NC \rightarrow	2 NO	1 NC / 1 NO overlapping \rightarrow
Slow-action system	6083000362 IN62-U1 FF 20 11,2 2,8 0 [°] 20 11,2 5,6 0 [°]	6083000364 IN62-A2 FF 20 2,8 0 [°] 20 11,2 5,6 0 [°]	6083000366 IN62-E2 FF 20 11,2 0 [°] 20 11,2 5,6 0 [°]	6083000367 IN62-UV1 FF 20 11,2 5,6 0 [°] 20 11,2 5,6 0 [°]
Snap-action system	6083000361 IN62-SU1 FF 20 13 4,4 0 [°] 20 11,2 3,3 0 [°]	6083000363 IN62-SA2 FF 20 11,2 3,3 0 [°] 20 14,2 5,6 0 [°]	6083000365 IN62-SE2 FF 20 14,2 5,6 0 [°] 20 14,2 5,6 0 [°]	



IN62-... VKW left

1 NC / 1 NO →	2 NC →	2 NO	1 NC / 1 NO overlapping →
---------------	--------	------	---------------------------

Slow-action system

6083000393
IN62-U1Z VKW LI

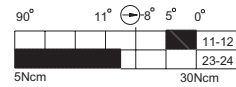

6083000396
IN62-A2Z VKW LI

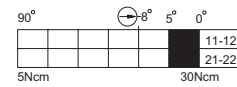

Snap-action system

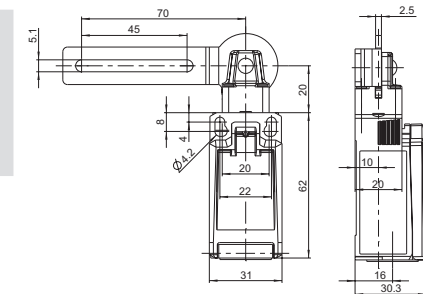

IN62-... VKW right

1 NC / 1 NO →	2 NC →	2 NO	1 NC / 1 NO overlapping →
---------------	--------	------	---------------------------

Slow-action system

6083000392
IN62-U1Z VKW RE

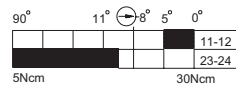

6083000394
IN62-A2Z VKW RE

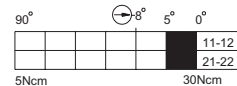

Snap-action system

6083000395
IN62-SA2Z VKW RE

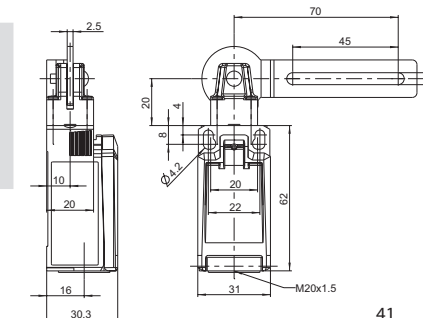
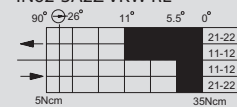

POSITION SWITCHES PLASTIC IN62, IN65



IN62-... VKS

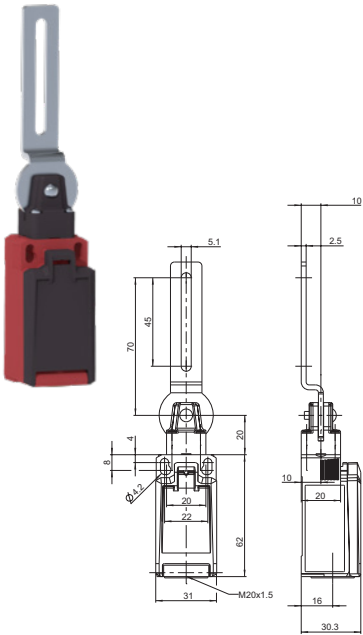

	1 NC / 1 NO \rightarrow	2 NC \rightarrow	2 NO	1 NC / 1 NO overlapping \rightarrow
--	---------------------------	--------------------	------	---------------------------------------

Slow-action system

6083000390
IN62-U1Z VKS

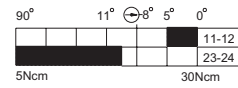

6083000389
IN62-A2Z VKS

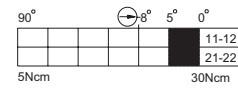

6083000391
IN62-UV1Z VKS

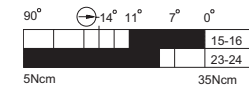

Snap-action system

IN62-... TASTER

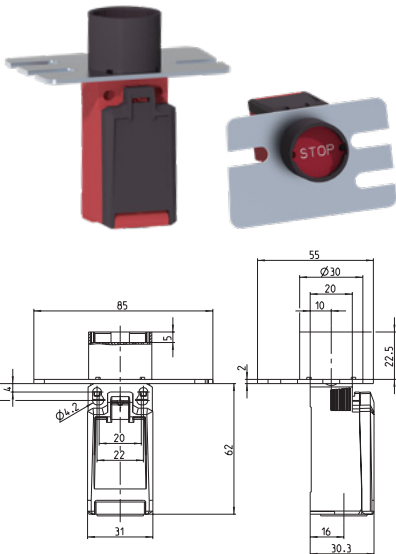

	1 NC / 1 NO \rightarrow	2 NC \rightarrow	2 NO	1 NC / 1 NO overlapping \rightarrow
--	---------------------------	--------------------	------	---------------------------------------

Slow-action system

6183000261
IN62-U1Z TASTER

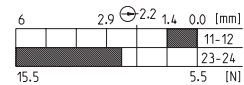

6183000262
IN62-A2Z TASTER

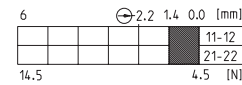

6183000260
IN62-UV1Z TASTER

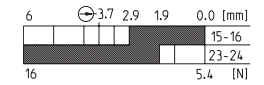

Snap-action system

6183000263
IN62-SU1Z TASTER

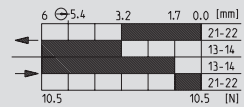

Replacement actuator: 3918052341

IN65-... SM

	1 NC / 1 NO \rightarrow	2 NC \rightarrow	2 NO	1 NC / 1 NO overlapping \rightarrow
Slow-action system	6083000208 IN65-U1Z SM 18 5 [N]	6083000210 IN65-A2Z SM 17 4 [N]	6083000212 IN65-E2 SM 19 6 [N]	6083000213 IN65-UV1Z SM 18 5 [N]
Snap-action system	6083000207 IN65-SU1Z SM 13 10 [N]	6083000209 IN65-SA2Z SM 13 10 [N]	6083000211 IN65-SE2 SM 13 10 [N]	

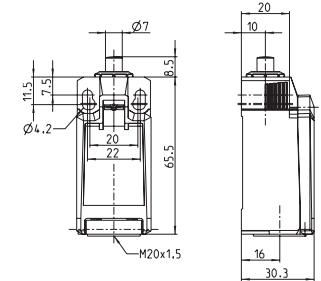

Replacement actuator: 3918172342

IN65-... RK

	1 NC / 1 NO \rightarrow	2 NC \rightarrow	2 NO	1 NC / 1 NO overlapping \rightarrow
Slow-action system	6083000215 IN65-U1Z RK 18 5 [N]	6083000217 IN65-A2Z RK 17 4 [N]	6083000219 IN65-E2 RK 19 6 [N]	6083000220 IN65-UV1Z R 18 5 [N]
Snap-action system	6083000214 IN65-SU1Z RK 13 10 [N]	6083000216 IN65-SA2Z RK 13 10 [N]	6083000218 IN65-SE2 RK 13 10 [N]	

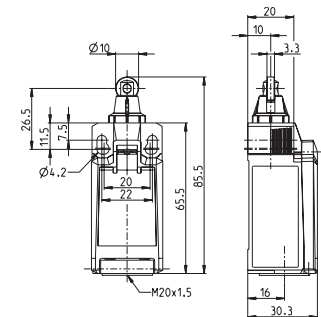

POSITION SWITCHES PLASTIC IN65

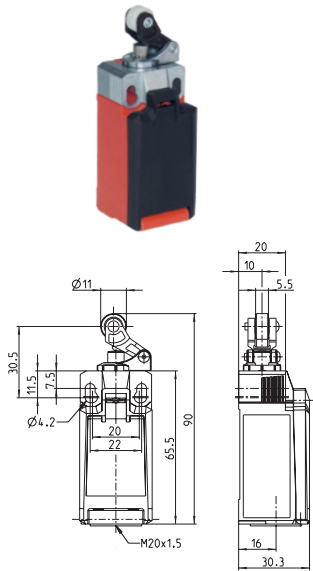

IN65-... HK

Replacement actuator: 3918202343



	1 NC / 1 NO \rightarrow	2 NC \rightarrow	2 NO	1 NC / 1 NO overlapping \rightarrow
Slow-action system	6083000222 IN65-U1Z HK 7,7 2,3 \oplus 3,2 1,3 0 [mm] 5 [N]	6083000224 IN65-A2Z HK 7,7 2,3 \oplus 1,3 0 [mm] 4 [N]	6083000226 IN65-E2 HK 7,7 3,2 0 [mm] 6 [N]	6083000227 IN65-UV1Z HK 7,7 4,2 \oplus 3,2 1,9 0 [mm] 5 [N]
Snap-action system	6083000221 IN65-SU1Z HK 7,7 6,6 \oplus 3,6 1,7 0 [mm] 10 [N]	6083000223 IN65-SA2Z HK 7,7 7 \oplus 3,2 1,4 0 [mm] 10 [N]	6083000225 IN65-SE2 HK 7,7 3,8 1,9 0 [mm] 10 [N]	

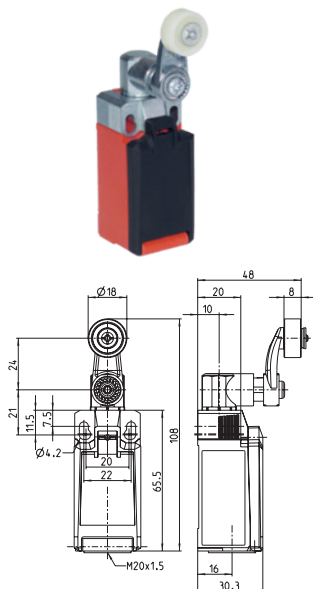

IN65-... AHK

Replacement actuator: 3918352345



	1 NC / 1 NO \rightarrow	2 NC \rightarrow	2 NO	1 NC / 1 NO overlapping \rightarrow
Slow-action system	6083000236 IN65-U1Z AHK 75,6° 25,9° \oplus 34,8° 15,6° 0° 11,1 9,1 8,9 7,3 [Ncm]	6083000238 IN65-A2Z AHK 75,6° 25,9° \oplus 15,6° 0° 9,7 8,8 7,1 [Ncm]	6083000240 IN65-E2 AHK 75,6° 34,8° 0° 11,8 6,9 [Ncm]	6083000241 IN65-UV1Z AHK 75,6° 45,1° \oplus 34,8° 22° 0° 11,9 10,8 9,1 6,7 [Ncm]
Snap-action system	6083000235 IN65-SU1Z AHK 75,6° 66,2° \oplus 38,7° 19,5° 0° 14,7 11,3 10,7 9,8 [Ncm]	6083000237 IN65-SA2Z AHK 75,6° 69,7° \oplus 34,8° 17° 0° 13,8 11 12,4 8,9 [Ncm]	6083000239 IN65-SE2 AHK 75,6° 41,2° 22° 0° 11,4 11,4 10,5 [Ncm]	



IN65-... AVK

	1 NC / 1 NO \rightarrow	2 NC \rightarrow	2 NO	1 NC / 1 NO overlapping \rightarrow
Slow-action system	6083000284 IN65-U1 AVK 75,6° 34,8° 15,6° 0° 22,7 11,1 8,9 7,3 [Ncm]	6083000279 IN65-A2 AVK 75,6° 15,6° 0° 22,7 8,8 7,1 [Ncm]	6083000287 IN65-E2 AVK 75,6° 34,8° 0° 22,9 11,8 6,9 [Ncm]	6083000285 IN65-UV1 AVK 75,6° 34,8° 22° 0° 23,5 10,8 9,1 6,7 [Ncm]
Snap-action system	6083000280 IN65-SU1 AVK 75,6° 38,7° 19,5° 0° 22,7 11,3 10,7 9,8 [Ncm]	6083000286 IN65-SA2 AVK 75,6° 34,8° 17° 0° 22,5 11 12,4 8,9 [Ncm]	6083000288 IN65-SE2 AVK 75,6° 41,2° 22° 0° 23,2 11,4 11,4 10,5 [Ncm]	

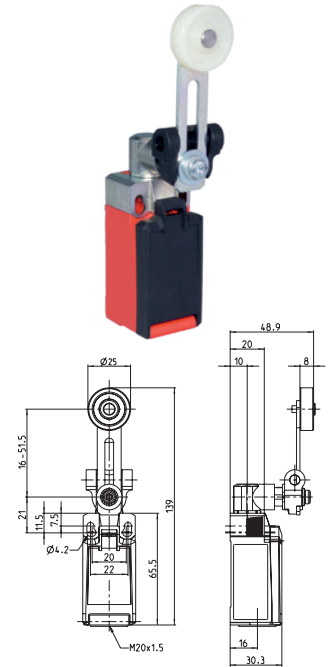

Replacement actuator: 3918262349

IN65-... KNK

	1 NC / 1 NO \rightarrow	2 NC \rightarrow	2 NO	1 NC / 1 NO overlapping \rightarrow
Slow-action system	6083000262 IN65-U1Z KNK 10,1 3,2 \rightarrow 4,4 1,9 0 [mm] 18 5 [N]	6083000264 IN65-A2Z KNK 10,1 3,2 \rightarrow 1,9 0 [mm] 17 4 [N]	6083000266 IN65-E2 KNK 10,1 4,4 0 [mm] 19 6 [N]	6083000267 IN65-UV1Z KNK 10,1 5,8 \rightarrow 4,4 2,7 0 [mm] 18 5 [N]
Snap-action system	6083000261 IN65-SU1Z KNK 10,1 8,7 \rightarrow 4,9 2,4 0 [mm] 13 10 [N]	6083000263 IN65-SA2Z KNK 10,1 9,2 \rightarrow 4,4 2,0 0 [mm] 13 10 [N]	6083000265 IN65-SE2 KNK 10,1 5,2 2,7 0 [mm] 13 10 [N]	

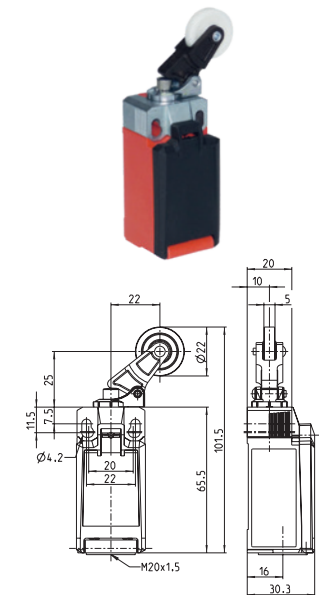

POSITION SWITCHES PLASTIC IN65

IN65-... DGKK

Replacement actuator: 3918202348

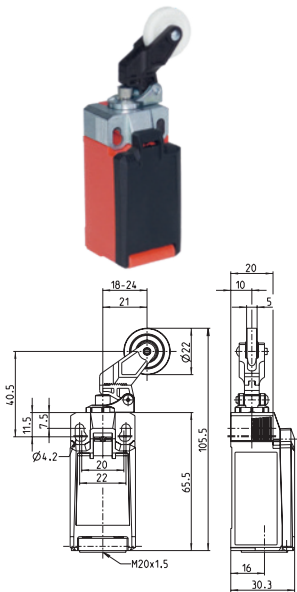

	1 NC / 1 NO \rightarrow	2 NC \rightarrow	2 NO	1 NC / 1 NO overlapping \rightarrow
Slow-action system	6083000255 IN65-U1Z DGKK 11,8 3,8 \oplus 5,2 2,2 0 [mm] 18 5 [N]	6083000257 IN65-A2Z DGKK 11,8 3,8 \oplus 2,2 0 [mm] 17 4 [N]	6083000259 IN65-E2 DGKK 11,8 5,2 0 [mm] 19 6 [N]	6083000260 IN65-UV1Z DGKK 11,8 6,8 \oplus 5,2 3,2 0 [mm] 18 5 [N]
Snap-action system	6083000254 IN65-SU1Z DGKK 11,8 10,2 \oplus 5,8 2,8 0 [mm] 13 10 [N]	6083000256 IN65-SA2Z DGKK 11,8 10,4 \oplus 5,2 2,4 0 [mm] 13 10 [N]	6083000258 IN65-SE2 DGKK 11,8 6,2 3,2 0 [mm] 13 10 [N]	

IN65-... DGHK

Replacement actuator: 3918202344

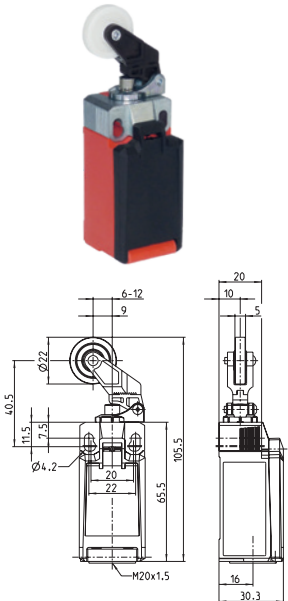

	1 NC / 1 NO \rightarrow	2 NC \rightarrow	2 NO	1 NC / 1 NO overlapping \rightarrow
Slow-action system	6083000229 IN65-U1Z DGHK 12,7 3,7 \oplus 5,2 2,1 0 [mm] 18 5 [N]	6083000231 IN65-A2Z DGHK 12,7 3,7 \oplus 2,1 0 [mm] 17 4 [N]	6083000233 IN65-E2 DGHK 12,7 5,2 0 [mm] 19 6 [N]	6083000234 IN65-UV1Z DGHK 12,7 6,9 \oplus 5,2 3,1 0 [mm] 18 5 [N]
Snap-action system	6083000228 IN65-SU1Z DGHK 12,7 10,7 \oplus 5,8 2,7 0 [mm] 13 10 [N]	6083000230 IN65-SA2Z DGHK 12,7 11,4 \oplus 5,2 2,3 0 [mm] 13 10 [N]	6083000232 IN65-SE2 DGHK 12,7 6,2 3,1 0 [mm] 13 10 [N]	



Replacement actuator: 3918352406

IN65-... AHDB

	1 NC / 1 NO \rightarrow	2 NC \rightarrow	2 NO	1 NC / 1 NO overlapping \rightarrow
Slow-action system	6083000345 IN65-U1Z AHDB 	6083000347 IN65-A2Z AHDB 	6083000349 IN65-E2 AHDB 	6083000350 IN65-UV1Z AHDB
Snap-action system	6083000344 IN65-SU1Z AHDB 	6083000346 IN65-SA2Z AHDB 	6083000348 IN65-SE2 AHDB 	

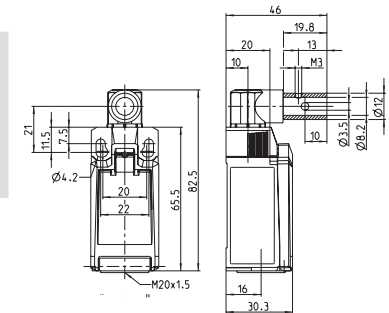

Replacement actuator: 3918352359

IN65-... AHSGU RO50

	1 NC / 1 NO \rightarrow	2 NC \rightarrow	2 NO	1 NC / 1 NO overlapping \rightarrow
Slow-action system	6083000296 IN65-U1Z AHSGU RO50 	6083000297 IN65-A2Z AHSGU RO50 	6083000298 IN65-E2 AHSGU RO50 	6083000299 IN65-UV1Z AHSGU RO50
Snap-action system	6083000300 IN65-SU1Z AHSGU RO50 	6083000301 IN65-SA2Z AHSGU RO50 	6083000302 IN65-SE2 AHSGU RO50 	

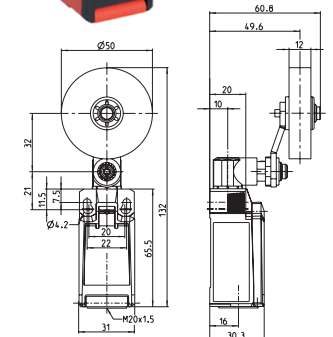

POSITION SWITCHES PLASTIC IN65

IN65-... AHDM

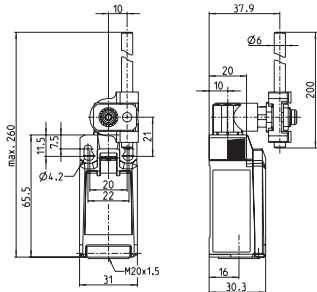

	1 NC / 1 NO \rightarrow	2 NC \rightarrow	2 NO	1 NC / 1 NO overlapping \rightarrow
--	---------------------------	--------------------	------	---------------------------------------

Slow-action system	6083000303 IN65-U1 AHDM	6083000304 IN65-A2 AHDM	6083000305 IN65-E2 AHDM	6083000306 IN65-UV1 AHDM
	75,6° 34,8° 15,6° 0°	75,6° 15,6° 0°	75,6° 34,8° 0°	75,6° 34,8° 22° 0°
	22,7 11,1 8,9 7,3 [Ncm]	22,7 8,8 7,1 [Ncm]	22,9 11,8 6,9 [Ncm]	23,5 10,8 9,1 6,7 [Ncm]

Snap-action system	6083000307 IN65-SU1 AHDM	6083000308 IN65-SA2 AHDM	6083000309 IN65-SE2 AHDM
	75,6° 38,7° 19,5° 0°	75,6° 34,8° 17° 0°	75,6° 41,2° 22° 0°
	22,7 11,3 10,7 9,8 [Ncm]	22,5 11 12,4 8,9 [Ncm]	23,2 11,4 11,4 10,5 [Ncm]

IN65-... AF

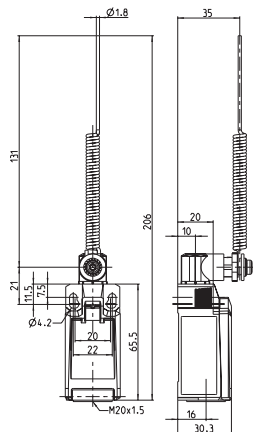

	1 NC / 1 NO \rightarrow	2 NC \rightarrow	2 NO	1 NC / 1 NO overlapping \rightarrow
--	---------------------------	--------------------	------	---------------------------------------

Slow-action system	6083000338 IN65-U1 AF	6083000340 IN65-A2 AF	6083000342 IN65-E2 AF	6083000343 IN65-UV1 AF
	75,6° 34,8° 15,6° 0°	75,6° 15,6° 0°	75,6° 34,8° 0°	75,6° 34,8° 22° 0°
	22,7 11,1 8,9 7,3 [Ncm]	22,7 8,8 7,1 [Ncm]	22,9 11,8 6,9 [Ncm]	23,5 10,8 9,1 6,7 [Ncm]

Snap-action system	6083000337 IN65-SU1 AF	6083000339 IN65-SA2 AF	6083000341 IN65-SE2 AF
	75,6° 38,7° 19,5° 0°	75,6° 34,8° 17° 0°	75,6° 41,2° 22° 0°
	22,7 11,3 10,7 9,8 [Ncm]	22,5 11 12,4 8,9 [Ncm]	23,2 11,4 11,4 10,5 [Ncm]

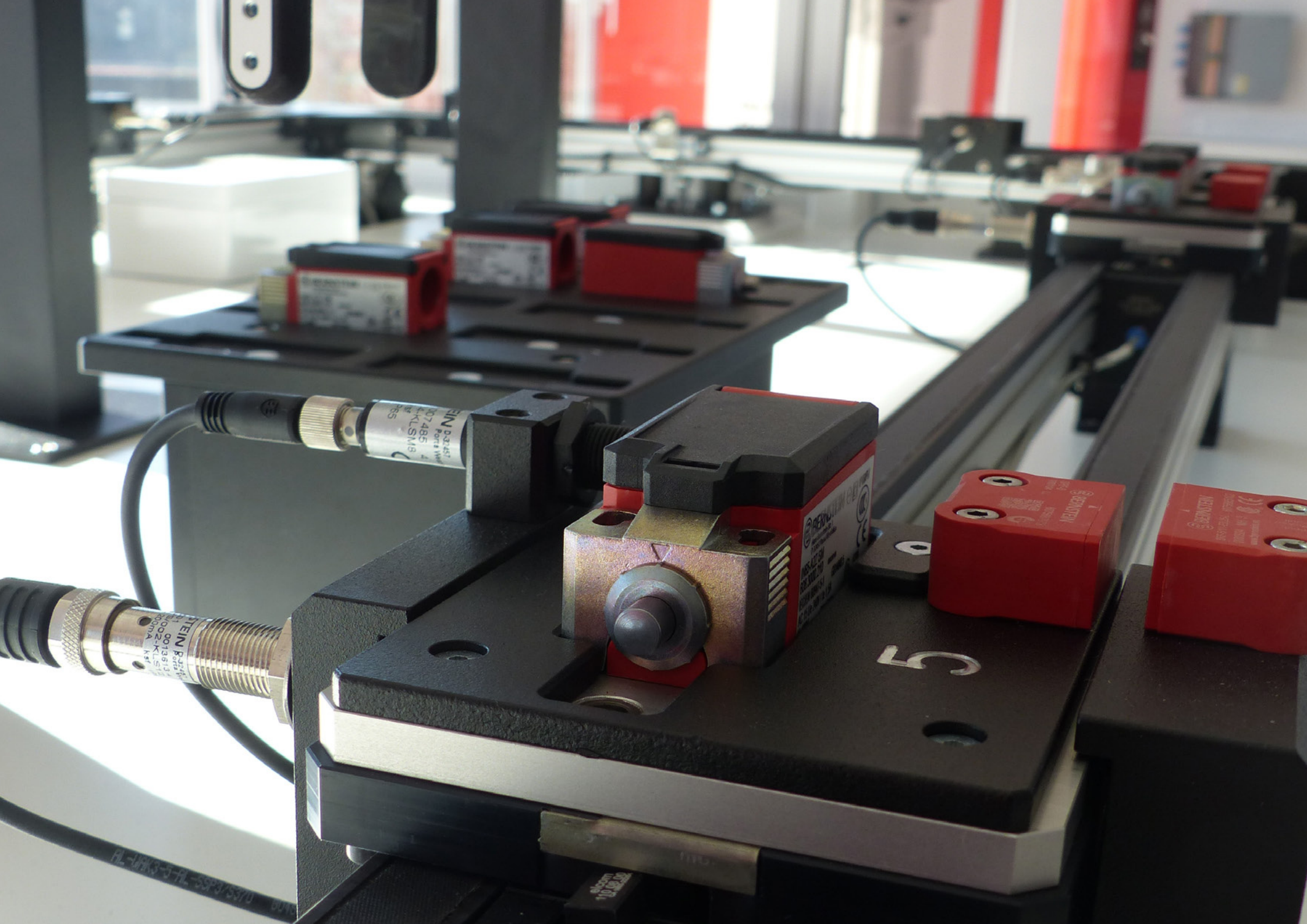

STEIN P-2-16
1 0013613
1002-KL5
1002-KL5
1002-KL5

STEIN P-2-16
1 0013613
1002-KL5
1002-KL5
1002-KL5

5

POSITION SWITCHES PLASTIC I81



I81-... SM



1 NC / 1 NO →

Slow-action system

6083000242
I81-U1Z SM

		R 0,8		
		0,9		
6	2,4	1,7	0	[mm]
		11-12		
		23-24		
[N]				

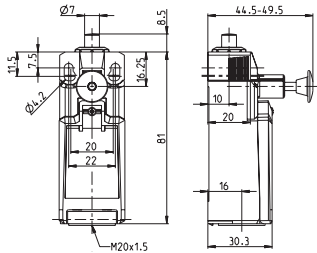

Replacement actuator: 3918052341



I81-... RK



1 NC / 1 NO →

Slow-action system

6083000243
I81-U1Z RK

		R 0,8		
		0,9		
6	2,4	1,7	0	[mm]
		11-12		
		23-24		
[N]				

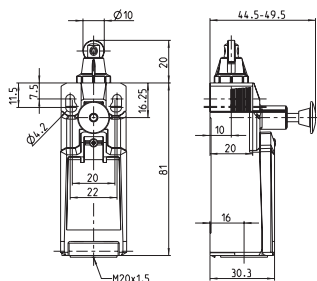

Replacement actuator: 3918172342



I81-... KNK



1 NC / 1 NO →

Slow-action system

6083000269
I81-U1Z KNK

		R 1,4		
		1,5		
10,1	4,0	2,8	0	[mm]
		11-12		
		23-24		
[N]				

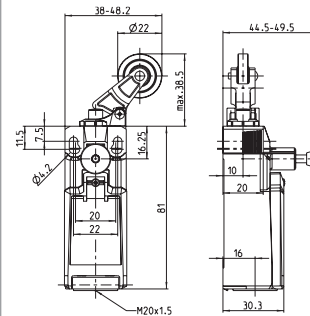

Replacement actuator: 3918262349



I81-... HK



1 NC / 1 NO →

Slow-action system

6083000244
I81-U1Z HK

		R 1,0		
		1,1		
7,7	2,9	2,0	0	[mm]
		11-12		
		23-24		
[N]				

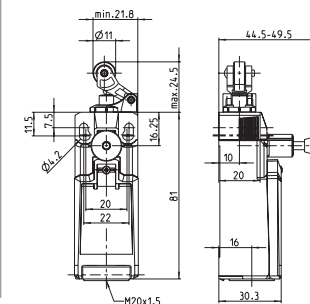

Replacement actuator: 3918202343

I81-... AHK



1 NC / 1 NO →

Slow-action system

6083000246
I81-U1Z AHK

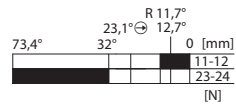

Replacement actuator: 3918352345

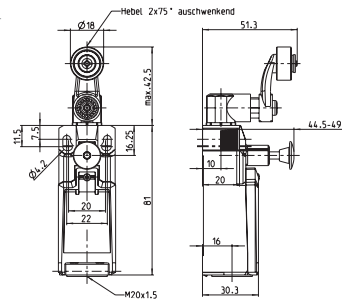

I81-... DGHK



1 NC / 1 NO →

Slow-action system

6083000245
I81-U1Z DGHK

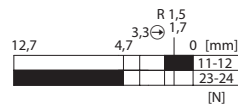

Replacement actuator: 3918202344

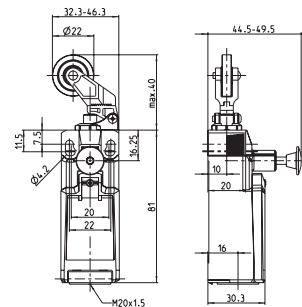

I81-... DGKK



1 NC / 1 NO →

Slow-action system

6083000268
I81-U1Z DGKK

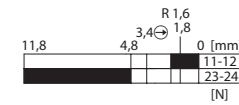

Replacement actuator: 3918202348

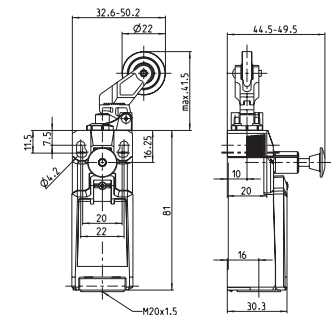

Plastic enclosures

Position switches Plastic IN73



2 OR 4 CONTACTS

Good to know ...

Our new standard switch, the IN73, is the latest in our ENK-series. It offers a modular, robust enclosure and a wide range of actuators made of metal. In mechanical and plant engineering, it is used as a position and safety switch in rough environments as it features additional fixing holes to achieve a better installation.

The “big brother” of the IN65, it has a similar modular design, however there is an important difference: Whereas the C14 switch insert (introduced on page 37) has 2 contacts, the IN73 can be equipped with the C17 switch insert with 4 contacts.

The modular design and the easy way to change the actuator allows for a great variety of applications, for example for monitoring doors, hoods, and flaps, or for detecting the position of moving machine parts. The IN73 is as cost effective as a plastic enclosed switch, robust to install like a metal switch, and clever due to its modular design and easy to change actuators.

Technical design

- Slow- and snap-action
- **Versions:**
 - With C14 switch insert: 2 NC, 2 NO, 1 NC/1 NO
 - With C17 switch insert: 4 NO, 4 NC, 2 NO/2 NC
 - 1 NC/3 NO and 3 NC/1 NO

Technical data

Electrical data		
Design insulation voltage	U_i max.	400 V AC
Conventional thermoelectric current	(up to) I_{the}	5 A
Rated operating voltage	U_e max.	240 V AC
Utilisation category (up to)		AC-15, U_e/I_e 240 V/3 A DC-13 U_e/I_e 24 V/1.5 A
Short-circuit protection (up to)		Safety fuse 4 A gG
Protection class		II, protective insulation
Mechanical data		
Enclosure/Cover material		Thermoplastics, glass-fibre reinforced (UL 94-V0)
Ambient temperature		-30 °C to +75 °C
Mechanical lifetime (up to)		10×10^6 switching cycles
B10d NC Contact cycles (up to)		20 million
B10d NO Contact cycles (up to)		1 million
Switching frequency		≤ 60 /min.
Type of connection		4 screwed connections (M3)
Conductor cross-sections		Single-wire 0.5 – 1.5 mm ² or strand with wire-end ferrule 0.5 – 1.5 mm ²
Cable entry		1 × M20 × 1.5
Protection class		IP66/IP67 according to EN 60529; DIN VDE 0470 T1
Standards		
VDE 0660 T211, DIN EN 60947-5-4, IEC 60947-5-4		
DIN EN ISO 13849-1, DIN EN ISO 13849-2		
① Depending on switching system		

Product characteristics

- High reliability at low currents (1 mA/24 VDC)
- Up to 4 contacts
- Actuator and installation collar with mounting holes made of metal
- Easy turning (8 x 45°) and changing of the actuators without a tool
- Standard switch and standard actuator according to DIN EN 50041
- Protection class IP66 and IP67 according to EN 60529



Options

- Available with an M12 connector
- On request, available with customised cables and connectors

Mounting

- 2 oval holes for adjustment for M5 screws
- 2 round holes for M5 screws for fixing when used for safety applications

POSITION SWITCHES PLASTIC IN73

IN73-... SM

Replacement actuator: 3918022415

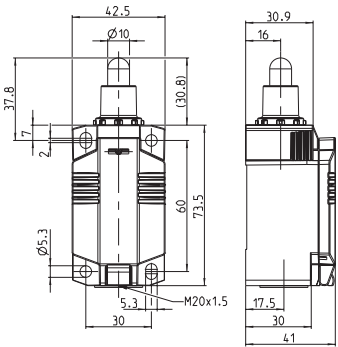

	1 NC / 1 NO	2 NC	2 NO	2 NC / 2 NO
--	-------------	------	------	-------------

Slow-action system

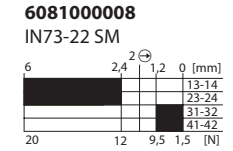
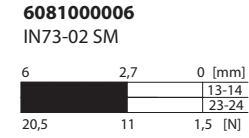
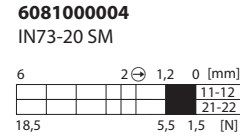
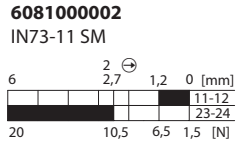

Snap-action system

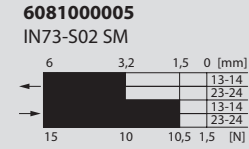
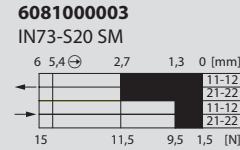
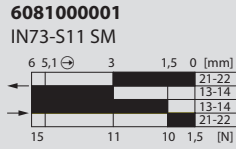

	4 NC	4 NO	3 NC / 1 NO	1 NC / 3 NO	1 NC / 1 NO overlapping
--	------	------	-------------	-------------	-------------------------

Slow-action system

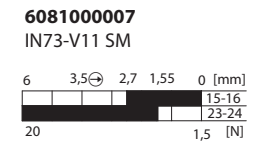
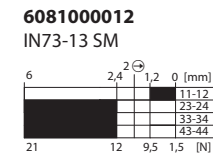
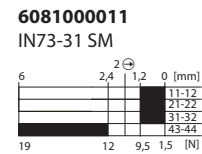
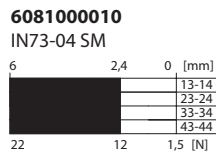
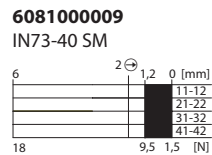



Replacement actuator: 3918172417

IN73-... RM

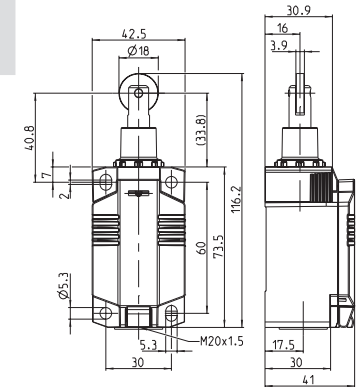

	1 NC / 1 NO	2 NC	2 NO	2 NC / 2 NO
--	-------------	------	------	-------------

Slow-action system

6081000014
IN73-11 RM

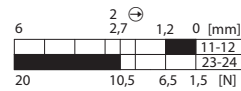

6081000016
IN73-20 RM

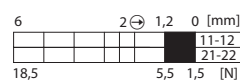

6081000018
IN73-02 RM

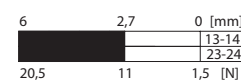

6081000020
IN73-22 RM

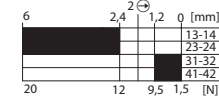

Snap-action system

6081000013
IN73-S11 RM



6081000015
IN73-S20 RM



6081000017
IN73-S02 RM

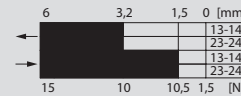

	4 NC	4 NO	3 NC / 1 NO	1 NC / 3 NO	1 NC / 1 NO overlapping
--	------	------	-------------	-------------	-------------------------

Slow-action system

6081000021
IN73-40 RM

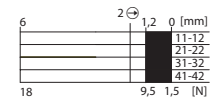

6081000022
IN73-04 RM

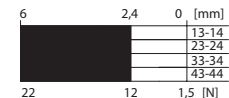

6081000023
IN73-31 RM

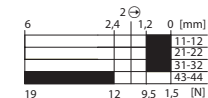

6081000024
IN73-13 RM

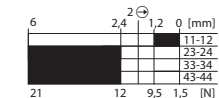

6081000019
IN73-V11 RM

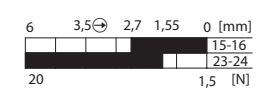

POSITION SWITCHES PLASTIC IN73

IN73-... HK

Replacement actuator: 3918202432

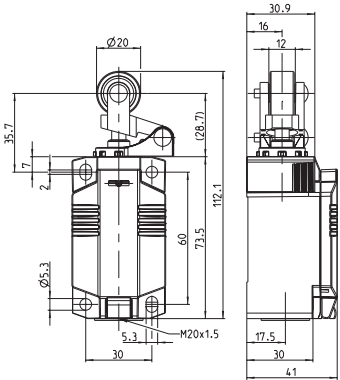

	1 NC / 1 NO	2 NC	2 NO	2 NC / 2 NO
--	-------------	------	------	-------------

Slow-action system

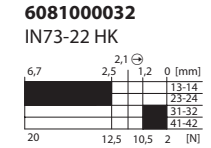
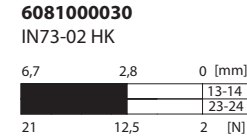
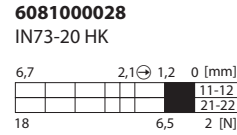
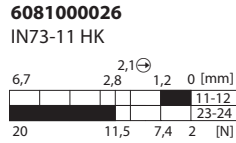

Snap-action system

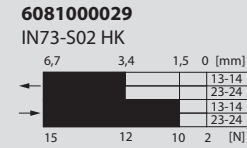
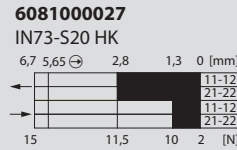
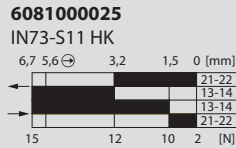

	4 NC	4 NO	3 NC / 1 NO	1 NC / 3 NO	1 NC / 1 NO overlapping
--	------	------	-------------	-------------	-------------------------

Slow-action system

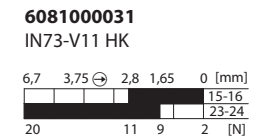
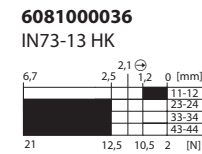
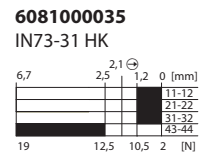
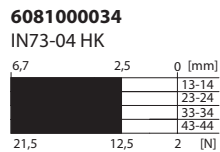
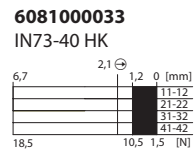



Replacement actuator: 3918202428

IN73-... DGHK

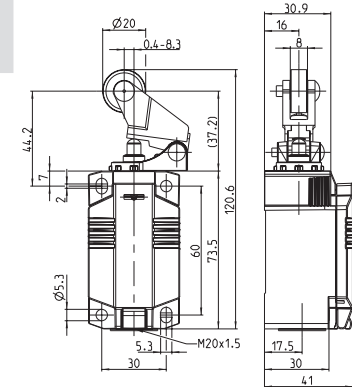

	1 NC / 1 NO	2 NC	2 NO	2 NC / 2 NO
--	-------------	------	------	-------------

Slow-action system

608100038
IN73-11 DGHK

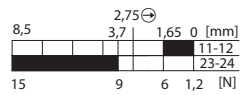

608100040
IN73-20 DGHK

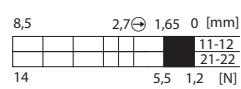

608100042
IN73-02 DGHK

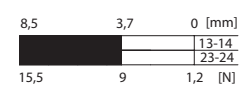

608100044
IN73-22 DGHK

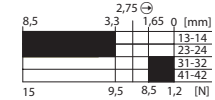

Snap-action system

608100037
IN73-S11 DGHK



608100039
IN73-S20 DGHK

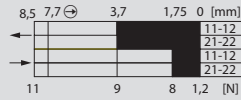

608100041
IN73-S02 DGHK



	4 NC	4 NO	3 NC / 1 NO	1 NC / 3 NO	1 NC / 1 NO overlapping
--	------	------	-------------	-------------	-------------------------

Slow-action system

608100045
IN73-40 DGHK

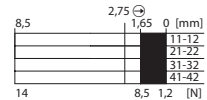

608100046
IN73-04 DGHK

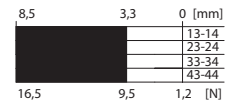

608100047
IN73-31 DGHK

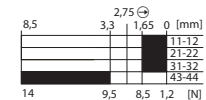

608100048
IN73-13 DGHK

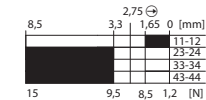

608100043
IN73-V11 DGHK

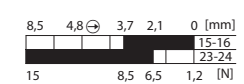

POSITION SWITCHES PLASTIC IN73

IN73-... DGKK

Replacement actuator: 3918202430

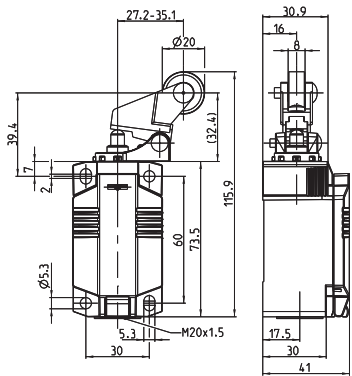

	1 NC / 1 NO	2 NC	2 NO	2 NC / 2 NO
--	-------------	------	------	-------------

Slow-action system	608100050 IN73-11 DGKK 	608100052 IN73-20 DGKK 	608100054 IN73-02 DGKK 	608100056 IN73-22 DGKK
--------------------	--------------------------------------	--------------------------------------	--------------------------------------	--------------------------------------

Snap-action system	608100049 IN73-S11 DGKK 	608100051 IN73-S20 DGKK 	608100053 IN73-S02 DGKK
--------------------	---------------------------------------	---------------------------------------	---------------------------------------

	4 NC	4 NO	3 NC / 1 NO	1 NC / 3 NO	1 NC / 1 NO overlapping
--	------	------	-------------	-------------	-------------------------

Slow-action system	608100057 IN73-40 DGKK 	608100058 IN73-04 DGKK 	608100059 IN73-31 DGKK 	608100060 IN73-13 DGKK 	608100055 IN73-V11 DGKK
--------------------	--------------------------------------	--------------------------------------	--------------------------------------	--------------------------------------	---------------------------------------



Replacement actuator: 3918352393

IN73-... AHK

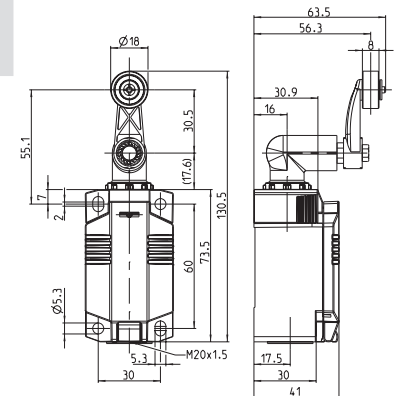

	1 NC / 1 NO	2 NC	2 NO	2 NC / 2 NO
--	-------------	------	------	-------------

Slow-action system	608100062 IN73-11 AHK 	608100064 IN73-20 AHK 	608100066 IN73-02 AHK 	608100068 IN73-22 AHK
--------------------	-------------------------------------	-------------------------------------	-------------------------------------	-------------------------------------

Snap-action system	608100061 IN73-S11 AHK 	608100063 IN73-S20 AHK 	608100065 IN73-S02 AHK
--------------------	--------------------------------------	--------------------------------------	--------------------------------------

	4 NC	4 NO	3 NC / 1 NO	1 NC / 3 NO	1 NC / 1 NO overlapping
--	------	------	-------------	-------------	-------------------------

Slow-action system	608100069 IN73-40 AHK 	608100070 IN73-04 AHK 	608100071 IN73-31 AHK 	608100072 IN73-13 AHK 	608100067 IN73-V11 AHK
--------------------	-------------------------------------	-------------------------------------	-------------------------------------	-------------------------------------	--------------------------------------

POSITION SWITCHES PLASTIC IN73

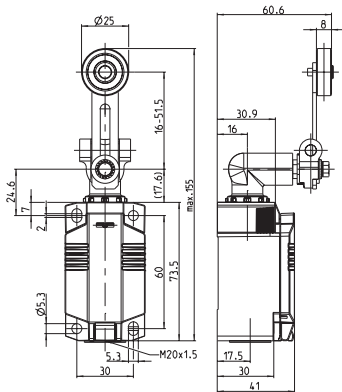

IN73-... AVK

Replacement actuator: 3918362424



	1 NC / 1 NO	2 NC	2 NO	2 NC / 2 NO
--	-------------	------	------	-------------

Slow-action system

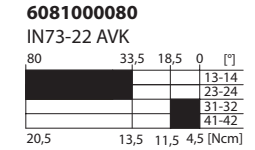
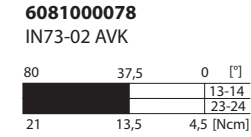
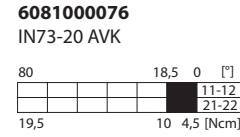
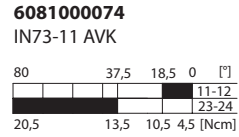

Snap-action system

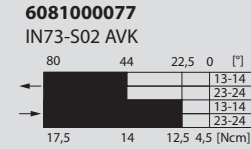
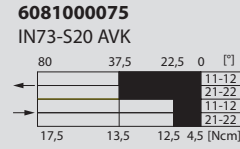
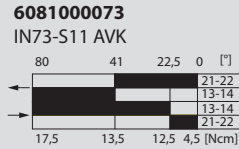

	4 NC	4 NO	3 NC / 1 NO	1 NC / 3 NO	1 NC / 1 NO overlapping
--	------	------	-------------	-------------	-------------------------

Slow-action system

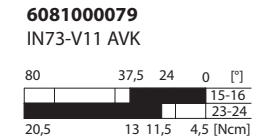
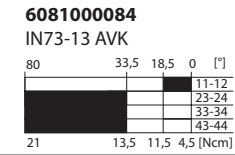
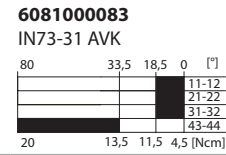
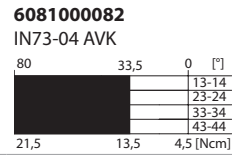
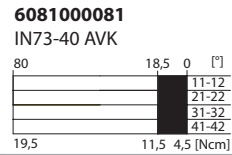



Replacement actuator: 3918372421

IN73-... AHDM

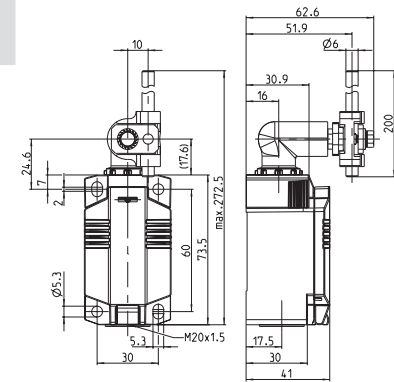

	1 NC / 1 NO	2 NC	2 NO	2 NC / 2 NO
--	-------------	------	------	-------------

Slow-action system	608100086 IN73-11 AHDM 	608100088 IN73-20 AHDM 	608100090 IN73-02 AHDM 	608100092 IN73-22 AHDM
--------------------	--------------------------------------	--------------------------------------	--------------------------------------	--------------------------------------

Snap-action system	608100085 IN73-S11 AHDM 	608100087 IN73-S20 AHDM 	608100089 IN73-S02 AHDM
--------------------	---------------------------------------	---------------------------------------	---------------------------------------

	4 NC	4 NO	3 NC / 1 NO	1 NC / 3 NO	1 NC / 1 NO overlapping
--	------	------	-------------	-------------	-------------------------

Slow-action system	608100093 IN73-40 AHDM 	608100094 IN73-04 AHDM 	608100095 IN73-31 AHDM 	608100096 IN73-13 AHDM 	608100091 IN73-V11 AHDM
--------------------	--------------------------------------	--------------------------------------	--------------------------------------	--------------------------------------	---------------------------------------

POSITION SWITCHES PLASTIC IN73



IN73-... AHGU RO50

Replacement actuator: 3918352422



	1 NC / 1 NO	2 NC	1 NC / 1 NO overlapping
--	-------------	------	-------------------------

Slow-action system

6081000109
IN73-11 AHGU Ro50

80	29	37,5	18,5	0	[°]
26,5	19	16	7,5	[Ncm]	

6081000110
IN73-20 AHGU Ro50

80	29	18,5	0	[°]
26	15,5 7,5 [Ncm]			

6081000111
IN73-V11 AHGU Ro50

80	48	37,5	24	0	[°]
26,5	19	17	7,5	[Ncm]	

Snap-action system

6081000108
IN73-S11 AHGU Ro50

80	68	41	22,5	0	[°]
24	19	18	7,5	[Ncm]	

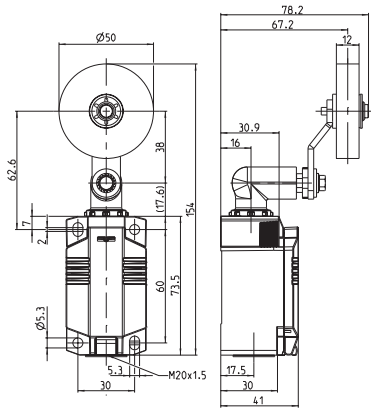



Replacement actuator: 3918362423

IN73-... AVGU RO50

	1 NC / 1 NO	2 NC	1 NC / 1 NO overlapping
Slow-action system	6081000105 IN73-11 AVGU Ro50 	6081000106 IN73-20 AVGU Ro50 	6081000107 IN73-V11 AVGU Ro50
Snap-action system	6081000104 IN73-S11 AVGU Ro50 		

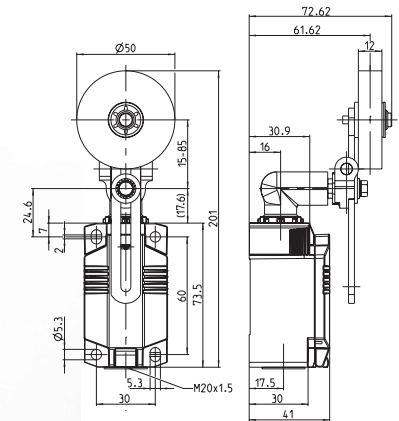
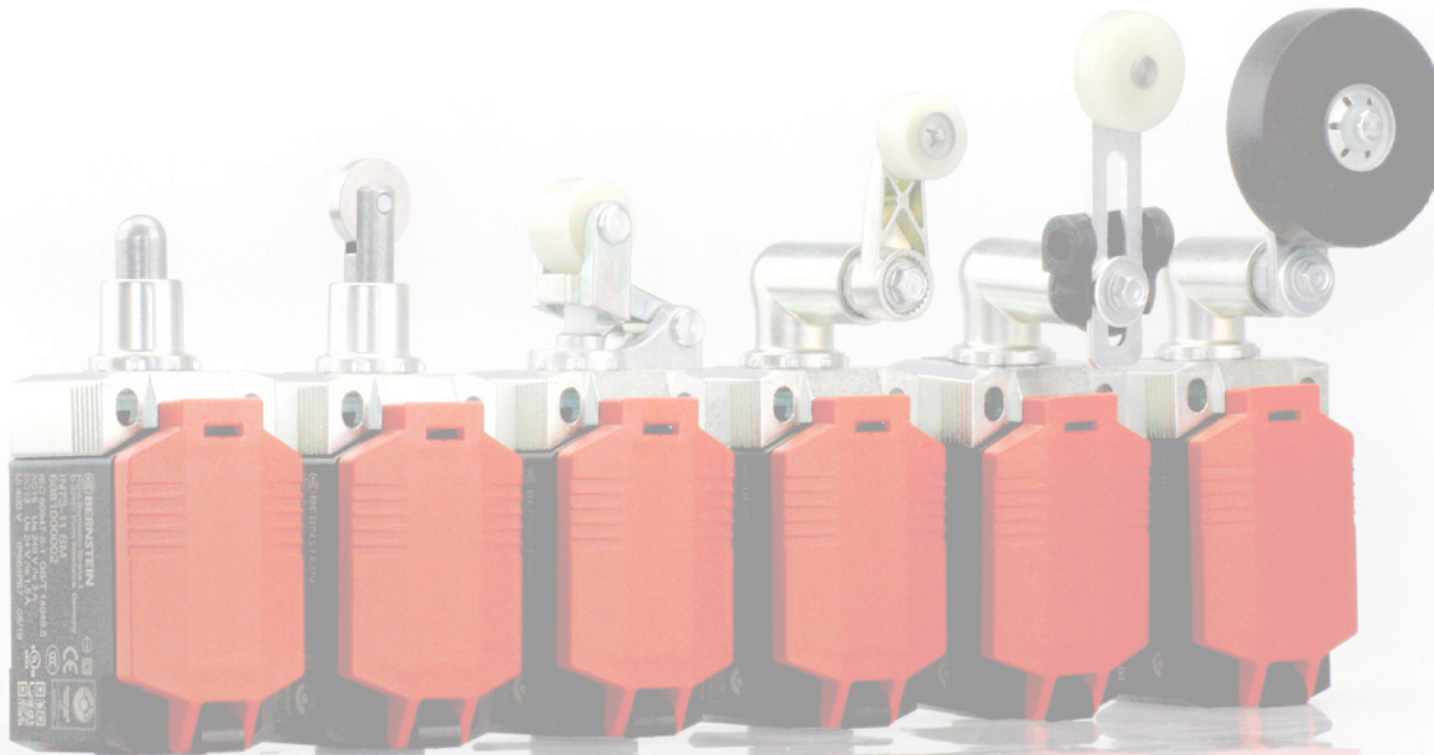

Metal enclosures

Position switches Metal M49



Product characteristics

- Flat and compact design
- Pre-installed connecting cable (1m length) for quick and easy installation
- Top-mounting versions available
- Cable or M12-connector outlet on the side or at the bottom
- High protection class IP67
- Suitable for safety applications according to DIN EN 60947-5-1 (positive break)

Good to know ...

Due to the space-saving enclosures and the high protection class IP67 the position switches of the M49 series are perfect for an installation where a flat design and a high protection class of IP67 is required. The switches are often used for the monitoring of covers and inspection doors, for position monitoring applications and similar applications. The high protection class allows outdoor applications.

Options

- Different cable lengths are available on request

Technical design

- Slow- and snap action
- **Versions:** 1 NC/1 NO, 2 NC, 2 NO, 2 NC/2 NO

Technical data

Electrical data		
Design insulation voltage	U_i max.	400 V AC
Conventional thermoelectric current	I_{the}	10 A
Rated operating voltage	U_e max.	240 V
Utilisation category		AC-15; 24 V / 10 A; 240 V / 3 A
Protection class		II, protective insulation
Mechanical data		
Ambient temperature		-25 °C to +70 °C (connecting cable firmly wired)
Mechanical lifetime		10 x 10 ⁶ switching cycles
Switching frequency		≤ 60/min.
Type of connection		Cable 4 x 0.75 mm ²
Protection class		IP67 conforming to IEC/EN 60529
Standards		
VDE 0660 T100, DIN EN 60947-1, IEC 60947-1		
VDE 0660 T200, DIN EN 60947-5-1, IEC 60947-5-1		

Application examples

- Position monitoring of moving parts
- Object detection in conveying technology
- End position control of components
- Position monitoring on rolling doors
- Monitoring of sliding doors



POSITION SWITCHES METAL M49

M49-... IW

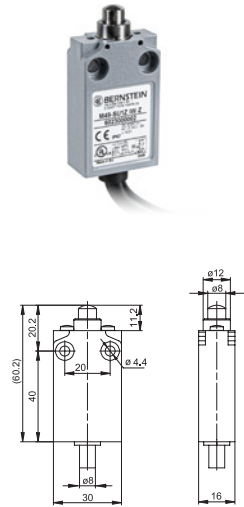

	1 NC / 1 NO Snap-action	1 NC / 1 NO Slow-action	2 NC Slow-action	2 NO Slow-action	2 NC / 2 NO Slow-action
Switching diagram					
Cable outlet right	602300001 M49-SU1Z IW	602300003 M49-U1Z IW	602300005 M49-A2Z IW	602300007 M49-E2 IW	602300009 M49-U2Z IW
Cable outlet below	602300002 M49-SU1Z IW Z	602300004 M49-U1Z IW Z	602300006 M49-A2Z IW Z	602300008 M49-E2 IW Z	602300010 M49-U2Z IW Z
M12 connector right	602300011 M49-SU1Z IW M12	602300013 M49-U1Z IW M12	602300015 M49-A2Z IW M12	602300017 M49-E2 IW M12	
M12 connector below	602300012 M49-SU1Z IW Z M12	602300014 M49-U1Z IW Z M12	602300016 M49-A2Z IW Z M12	602300018 M49-E2 IW Z M12	

M49-... AH

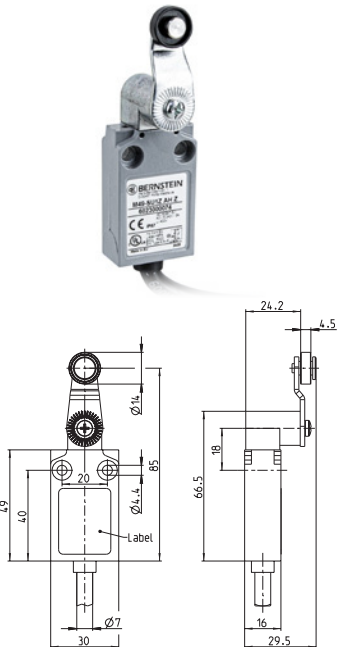

	1 NC / 1 NO Snap-action	1 NC / 1 NO Slow-action	2 NC Slow-action	2 NO Slow-action	2 NC / 2 NO Slow-action
Switching diagram					
Cable outlet right	6023000073 M49-SU1Z AH	6023000075 M49-U1Z AH	6023000077 M49-A2Z AH	6023000079 M49-E2 AH	6023000081 M49-U2Z AH
Cable outlet below	6023000074 M49-SU1Z AH Z	6023000076 M49-U1Z AH Z	6023000078 M49-A2Z AH Z	6023000080 M49-E2 AH Z	6023000082 M49-U2Z AH Z
M12 connector right	6023000083 M49-SU1Z AH M12	6023000085 M49-U1Z AH M12	6023000087 M49-A2Z AH M12	6023000089 M49-E2 AH M12	
M12 connector below	6023000084 M49-SU1Z AH Z M12	6023000086 M49-U1Z AH Z M12	6023000088 M49-A2Z AH Z M12	6023000090 M49-E2 AH Z M12	



M49-... RIW

	1 NC / 1 NO Snap-action	1 NC / 1 NO Slow-action	2 NC Slow-action	2 NO Slow-action	2 NC / 2 NO Slow-action
Switching diagram					
Cable outlet right	6023000019 M49-SU1Z RIW	6023000021 M49-U1Z RIW	6023000023 M49-A2Z RIW	6023000025 M49-E2 RIW	6023000027 M49-U2Z RIW
Cable outlet below	6023000020 M49-SU1Z RIW Z	6023000022 M49-U1Z RIW Z	6023000024 M49-A2Z RIW Z	6023000026 M49-E2 RIW Z	6023000028 M49-U2Z RIW Z
M12 connector right	6023000029 M49-SU1Z RIW M12	6023000031 M49-U1Z RIW M12	6023000033 M49-A2Z RIW M12	6023000035 M49-E2 RIW M12	
M12 connector below	6023000030 M49-SU1Z RIW Z M12	6023000032 M49-U1Z RIW Z M12	6023000034 M49-A2Z RIW Z M12	6023000036 M49-E2 RIW Z M12	

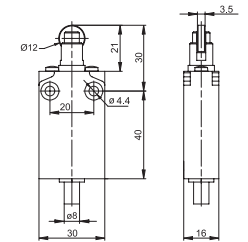

M49-... IWF

	1 NC / 1 NO Snap-action	1 NC / 1 NO Slow-action	2 NC Slow-action	2 NO Slow-action	2 NC / 2 NO Slow-action
Switching diagram					
Cable outlet right	6023000037 M49-SU1Z IWF	6023000039 M49-U1Z IWF	6023000041 M49-A2Z IWF	6023000043 M49-E2 IWF	6023000045 M49-U2Z IWF
Cable outlet below	6023000038 M49-SU1Z IWF Z	6023000040 M49-U1Z IWF Z	6023000042 M49-A2Z IWF Z	6023000044 M49-E2 IWF Z	6023000046 M49-U2Z IWF Z
M12 connector right	6023000047 M49-SU1Z IWF M12	6023000049 M49-U1Z IWF M12	6023000051 M49-A2Z IWF M12	6023000053 M49-E2 IWF M12	
M12 connector below	6023000048 M49-SU1Z IWF Z M12	6023000050 M49-U1Z IWF Z M12	6023000052 M49-A2Z IWF Z M12	6023000054 M49-E2 IWF Z M12	

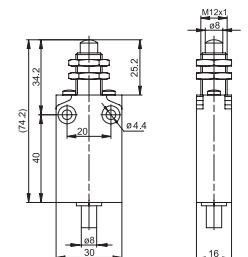

POSITION SWITCHES METAL M49

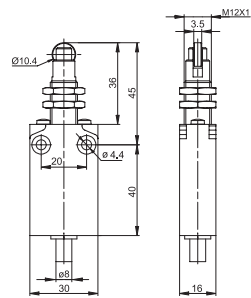

M49-... RIWF



	1 NC / 1 NO Snap-action	1 NC / 1 NO Slow-action	2 NC Slow-action	2 NO Slow-action	2 NC / 2 NO Slow-action
Switching diagram					
Cable outlet right	6023000055 M49-SU1Z RIWF	6023000057 M49-U1Z RIWF	6023000059 M49-A2Z RIWF	6023000061 M49-E2 RIWF	6023000063 M49-U2Z RIWF
Cable outlet below	6023000056 M49-SU1Z RIWF Z	6023000058 M49-U1Z RIWF Z	6023000060 M49-A2Z RIWF Z	6023000062 M49-E2 RIWF Z	6023000064 M49-U2Z RIWF Z
M12 connector right	6023000065 M49-SU1Z RIWF M12	6023000067 M49-U1Z RIWF M12	6023000069 M49-A2Z RIWF M12	6023000071 M49-E2 RIWF M12	
M12 connector below	6023000066 M49-SU1Z RIWF Z M12	6023000068 M49-U1Z RIWF Z M12	6023000070 M49-A2Z RIWF Z M12	6023000072 M49-E2 RIWF Z M12	

M49-... AV

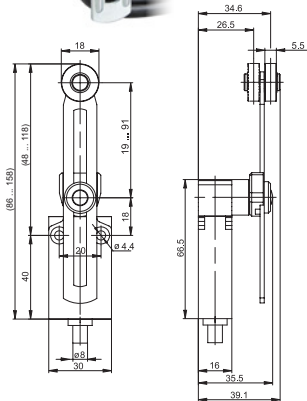

	1 NC / 1 NO Snap-action	1 NC / 1 NO Slow-action	2 NC Slow-action	2 NO Slow-action	2 NC / 2 NO Slow-action
Switching diagram					
Cable outlet right	6023000091 M49-SU1 AV	6023000093 M49-U1 AV	6023000095 M49-A2 AV	6023000097 M49-E2 AV	6023000099 M49-U2 AV
Cable outlet below	6023000092 M49-SU1 AV Z	6023000094 M49-U1 AV Z	6023000096 M49-A2 AV Z	6023000098 M49-E2 AV Z	6023000100 M49-U2 AV Z
M12 connector right	6023000101 M49-SU1 AV M12	6023000103 M49-U1 AV M12	6023000105 M49-A2 AV M12	6023000107 M49-E2 AV M12	
M12 connector below	6023000102 M49-SU1 AV Z M12	6023000104 M49-U1 AV Z M12	6023000106 M49-A2 AV Z M12	6023000108 M49-E2 AV Z M12	



M49-... AD

	1 NC / 1 NO Snap-action	1 NC / 1 NO Slow-action	2 NC Slow-action	2 NO Slow-action	2 NC / 2 NO Slow-action
Switching diagram					
Cable outlet right	6023000113 M49-SU1 AD	6023000115 M49-U1 AD	6023000117 M49-A2 AD	6023000119 M49-E2 AD	6023000121 M49-U2 AD
Cable outlet below	6023000114 M49-SU1 AD Z	6023000116 M49-U1 AD Z	6023000118 M49-A2 AD Z	6023000120 M49-E2 AD Z	6023000122 M49-U2 AD Z
M12 connector right	6023000123 M49-SU1 AD M12	6023000125 M49-U1 AD M12	6023000127 M49-A2 AD M12	6023000129 M49-E2 AD M12	
M12 connector below	6023000124 M49-SU1 AD Z M12	6023000126 M49-U1 AD Z M12	6023000128 M49-A2 AD Z M12	6023000130 M49-E2 AD Z M12	

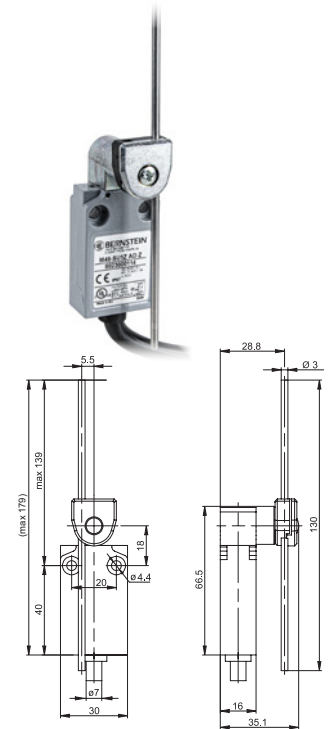

M49-... FF

	1 NC / 1 NO Snap-action	
Switching diagram		
Cable outlet right	6023000109 M49-SU1 FF	
Cable outlet below	6023000110 M49-SU1 FF Z	
M12 connector right	6023000111 M49-SU1 FF M12	
M12 connector below	6023000112 M49-SU1 FF Z M12	

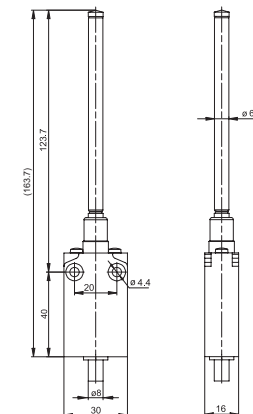

Metal enclosure

Position switches Metal MN78



2 OR 4 CONTACTS

Product characteristics

- Standard switch according to DIN EN 50041, standard actuator according to DIN EN 50041
- Protection class IP66 and IP67 conforming to EN 60529
- Enclosure: Die-cast aluminium
- Cover: Aluminium
- Actuator rotatable by $8 \times 45^\circ$
- Cable entry M20 \times 1.5

Good to know ...

The MN78 is the metal version of the IN73 and designed for the use in very rough environments. A modular, robust metal enclosure with a wide range of Metalast actuators. Just as with the IN73, the MN78 offers additional fixing holes for safe installation.

It can be equipped with the C14 or C17 switch insert (2 contacts or 4 contacts).

Rough environments, outdoor areas, or high mechanical loads are all no problem for the MN78.

Technical design

- Slow- and snap action
- **Versions:**
 With C14 switch insert: 2 NC, 2 NO, 1 NC/1 NO
 With C17 switch insert: 4 NO, 4 NC, 2 NO/2 NC
 1 NC/3 NO and 3 NC/1 NO

Technical data

Electrical data		
Design insulation voltage	U_i max.	400 V AC
Conventional thermoelectric current	(up to) I_{the}	5 A
Rated operating voltage	U_e max.	240 V AC/24 V DC
Utilisation category (up to)		AC-15, U_e/I_e 240 V/3 A DC-13 U_e/I_e 24 V/1.5 A (B300 Table A.1)
Short circuit protection (up to)		Safety fuse 4 A gG
Protection class		II, protective insulation
Mechanical data		
Enclosure material		Metal, glass-fibre reinforced (UL 94-V0)
Ambient temperature		-30 °C to +75 °C
Mechanical lifetime (up to)		30×10^6 switching cycles
B10d NC Contact cycles (up to)		20 million
B10d NO Contact cycles (up to)		1 million
Switching frequency		≤ 60 /min.
Type of connection		4 screwed connections (M3)
Conductor cross-sections		Single-wire 0.5 – 1.5 mm ² or strand with wire-end ferrule 0.5 – 1.5 mm ²
Cable entry		1 × M20 × 1.5
Protection class		IP66/IP67 according to EN 60529; DIN VDE 0470 T1
Standards		
VDE 0660 T211, DIN EN 60947-5-4, IEC 60947-5-4 DIN EN ISO 13849-1, DIN EN ISO 13849-2		
① Depending on switching system		

Options

- Available with M12 connector
- Customised cables and connectors are available on request

Mounting

- 2 screws M5, adjustment with oval holes
- 2 screws M5 for safety applications without additional fixation required



POSITION SWITCHES METAL MN78

MN78-... SM

Replacement actuator: 3918022415

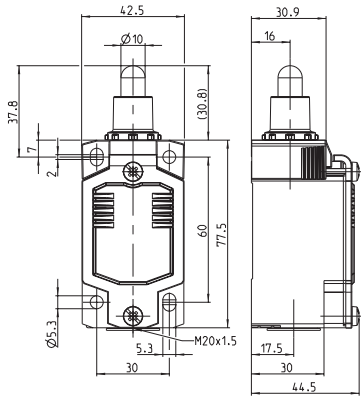

	1 NC / 1 NO	2 NC	2 NO	2 NC / 2 NO
--	-------------	------	------	-------------

Slow-action system	608700002 MN78-11 SM 	608700004 MN78-20 SM 	608700006 MN78-02 SM 	608700008 MN78-22 SM
--------------------	------------------------------------	------------------------------------	------------------------------------	------------------------------------

Snap-action system	608700001 MN78-S11 SM 	608700003 MN78-S20 SM 	608700005 MN78-S02 SM
--------------------	-------------------------------------	-------------------------------------	-------------------------------------

	4 NC	4 NO	3 NC / 1 NO	1 NC / 3 NO	1 NC / 1 NO overlapping
--	------	------	-------------	-------------	-------------------------

Slow-action system	608700009 MN78-40 SM 	608700010 MN78-04 SM 	608700011 MN78-31 SM 	608700012 MN78-13 SM 	608700007 MN78-V11 SM
--------------------	------------------------------------	------------------------------------	------------------------------------	------------------------------------	-------------------------------------



Replacement actuator: 3918172417

MN78-... RM

	1 NC / 1 NO	2 NC	2 NO	2 NC / 2 NO
--	-------------	------	------	-------------

Slow-action system

6087000014
MN78-11 RM

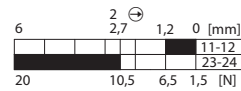

6087000016
MN78-20 RM

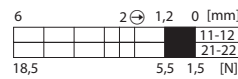

6087000018
MN78-02 RM

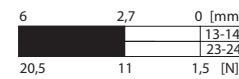

6087000020
MN78-22 RM

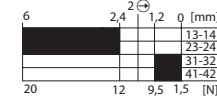

Snap-action system

6087000013
MN78-S11 RM



6087000015
MN78-S20 RM

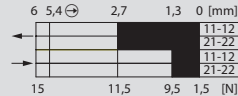

6087000017
MN78-S02 RM

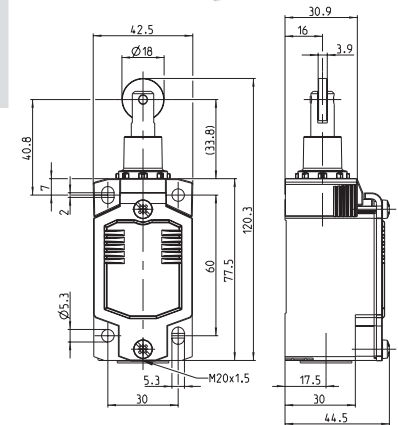
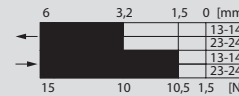

	4 NC	4 NO	3 NC / 1 NO	1 NC / 3 NO	1 NC / 1 NO overlapping
--	------	------	-------------	-------------	-------------------------

Slow-action system

6087000021
MN78-40 RM

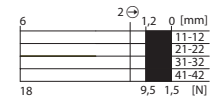

6087000022
MN78-04 RM

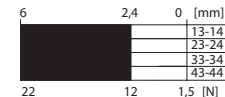

6087000023
MN78-31 RM

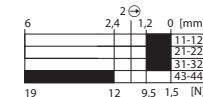

6087000024
MN78-13 RM

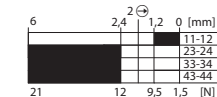

6087000019
MN78-V11 RM



POSITION SWITCHES METAL MN78

MN78-... HK

Replacement actuator: 3918202432

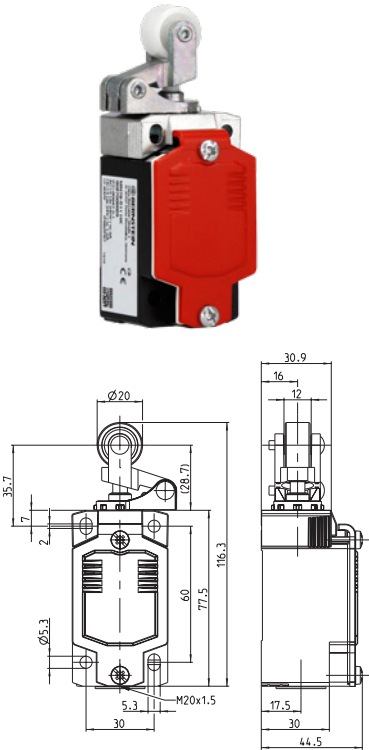

	1 NC / 1 NO	2 NC	2 NO	2 NC / 2 NO
--	-------------	------	------	-------------

Slow-action system	608700026 MN78-11 HK	608700028 MN78-20 HK	608700030 MN78-02 HK	608700032 MN78-22 HK
	6,7 2,8 1,2 0 [mm] 20 11,5 7,4 2 [N]	6,7 2,1 1,2 0 [mm] 18 6,5 2 [N]	6,7 2,8 0 [mm] 21 12,5 2 [N]	6,7 2,5 1,2 0 [mm] 20 12,5 10,5 2 [N]

Snap-action system	608700025 MN78-S11 HK	608700027 MN78-S20 HK	608700029 MN78-S02 HK
	6,7 5,6 3,2 1,5 0 [mm] 15 12 10 2 [N]	6,7 5,65 2,8 1,3 0 [mm] 15 11,5 10 2 [N]	6,7 3,4 1,5 0 [mm] 15 12 10 2 [N]

	4 NC	4 NO	3 NC / 1 NO	1 NC / 3 NO	1 NC / 1 NO overlapping
--	------	------	-------------	-------------	-------------------------

Slow-action system	608700033 MN78-40 HK	608700034 MN78-04 HK	608700035 MN78-31 HK	608700036 MN78-13 HK	608700031 MN78-V11 HK
	6,7 2,1 1,2 0 [mm] 18,5 10,5 1,5 [N]	6,7 2,5 0 [mm] 21,5 12,5 2 [N]	6,7 2,5 2,1 1,2 0 [mm] 19 12,5 10,5 2 [N]	6,7 2,5 2,1 1,2 0 [mm] 21 12,5 10,5 2 [N]	6,7 3,75 2,8 1,65 0 [mm] 20 11 9 2 [N]



Replacement actuator: 3918202428

MN78-... DGHK



	1 NC / 1 NO	2 NC	2 NO	2 NC / 2 NO
Slow-action system	6087000038 MN78-11 DGHK 	6087000040 MN78-20 DGHK 	6087000042 MN78-02 DGHK 	6087000044 MN78-22 DGHK
Snap-action system	6087000037 MN78-S11 DGHK 	6087000039 MN78-S20 DGHK 	6087000041 MN78-S02 DGHK 	

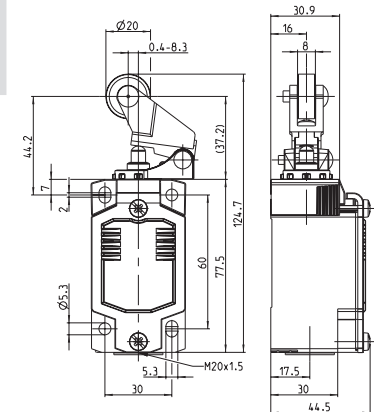

	4 NC	4 NO	3 NC / 1 NO	1 NC / 3 NO	1 NC / 1 NO overlapping
Slow-action system	6087000045 MN78-40 DGHK 	6087000046 MN78-04 DGHK 	6087000047 MN78-31 DGHK 	6087000048 MN78-13 DGHK 	6087000043 MN78-V11 DGHK

POSITION SWITCHES METAL MN78

MN78-... DGKK

Replacement actuator: 3918202430

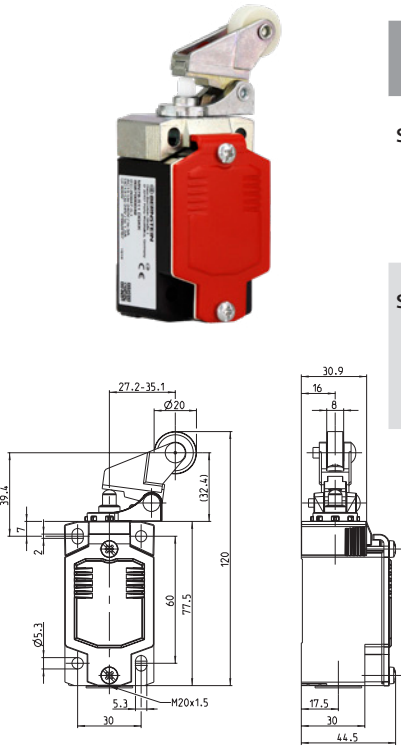

	1 NC / 1 NO	2 NC	2 NO	2 NC / 2 NO
--	-------------	------	------	-------------

Slow-action system

608700050
MN78-11 DGKK

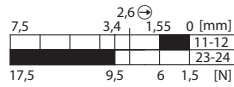

608700052
MN78-20 DGKK

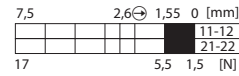

608700054
MN78-02 DGKK

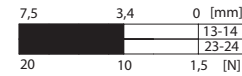

608700056
MN78-22 DGKK

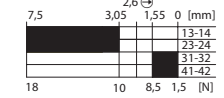

Snap-action system

608700049
MN78-S11 DGKK

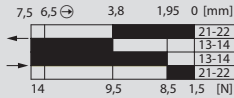

608700051
MN78-S20 DGKK

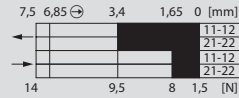

608700053
MN78-S02 DGKK

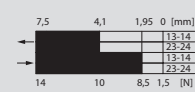

	4 NC	4 NO	3 NC / 1 NO	1 NC / 3 NO	1 NC / 1 NO overlapping
--	------	------	-------------	-------------	-------------------------

Slow-action system

608700057
MN78-40 DGKK

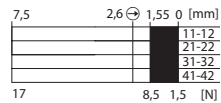

608700058
MN78-04 DGKK

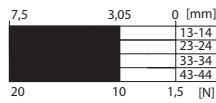

608700059
MN78-31 DGKK

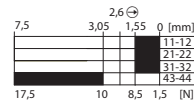

608700060
MN78-13 DGKK

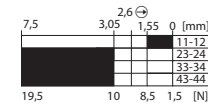

608700055
MN78-V11 DGKK

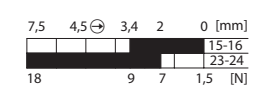



Replacement actuator: 3918352393

MN78-... AHK

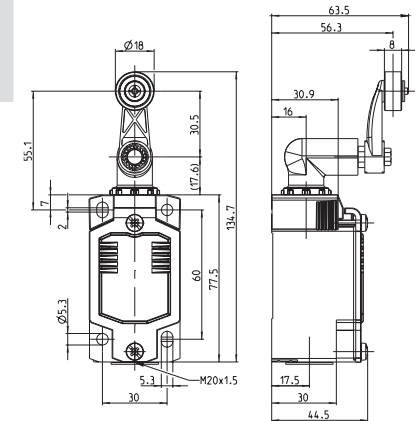

	1 NC / 1 NO	2 NC	2 NO	2 NC / 2 NO
--	-------------	------	------	-------------

Slow-action system	6087000062 MN78-11 AHK 20,5 13,5 10,5 4,5 [Ncm]	6087000064 MN78-20 AHK 19,5 10 4,5 [Ncm]	6087000066 MN78-02 AHK 21 13,5 4,5 [Ncm]	6087000068 MN78-22 AHK 20,5 13,5 11,5 4,5 [Ncm]
--------------------	--	---	---	--

Snap-action system	6087000061 MN78-S11 AHK 17,5 13,5 12,5 4,5 [Ncm]	6087000063 MN78-S20 AHK 17,5 13,5 12,5 4,5 [Ncm]	6087000065 MN78-S02 AHK 17,5 14 12,5 4,5 [Ncm]
--------------------	---	---	---

	4 NC	4 NO	3 NC / 1 NO	1 NC / 3 NO	1 NC / 1 NO overlapping
--	------	------	-------------	-------------	-------------------------

Slow-action system	6087000069 MN78-40 AHK 19,5 11,5 4,5 [Ncm]	6087000070 MN78-04 AHK 21,5 13,5 4,5 [Ncm]	6087000071 MN78-31 AHK 20 13,5 11,5 4,5 [Ncm]	6087000072 MN78-13 AHK 21 13,5 11,5 4,5 [Ncm]	6087000067 MN78-V11 AHK 20,5 13 11,5 4,5 [Ncm]
--------------------	---	---	--	--	---

POSITION SWITCHES METAL MN78

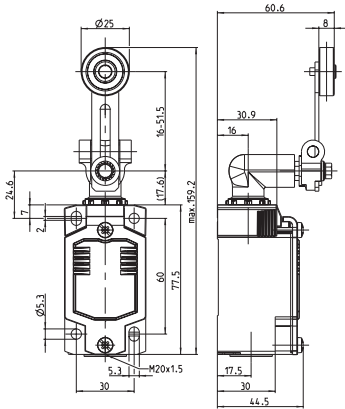

MN78-... AVK

Replacement actuator: 3918362424



	1 NC / 1 NO	2 NC	2 NO	2 NC / 2 NO
--	-------------	------	------	-------------

Slow-action system

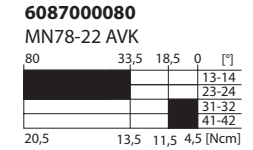
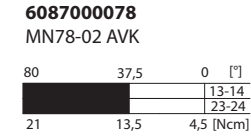
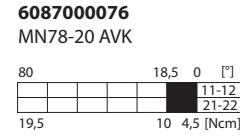
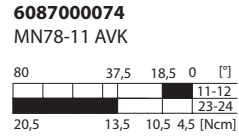

Snap-action system

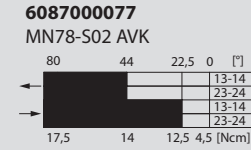
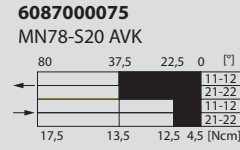
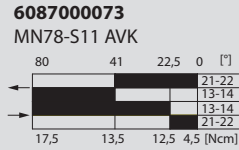

	4 NC	4 NO	3 NC / 1 NO	1 NC / 3 NO	1 NC / 1 NO overlapping
--	------	------	-------------	-------------	-------------------------

Slow-action system

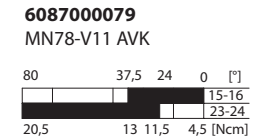
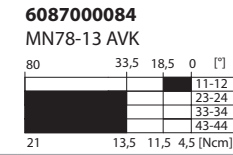
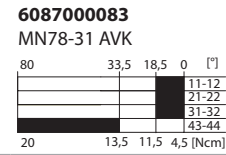
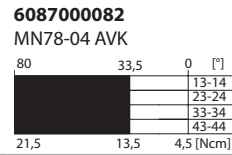
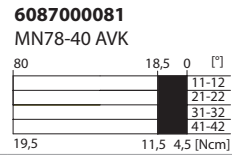



Replacement actuator: 3918372421

MN78-... AHDM

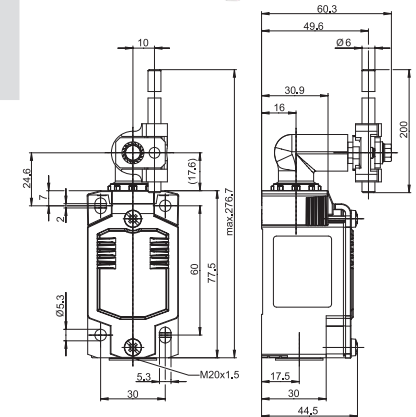

	1 NC / 1 NO	2 NC	2 NO	2 NC / 2 NO
--	-------------	------	------	-------------

Slow-action system	608700086 MN78-11 AHDM 	608700088 MN78-20 AHDM 	608700090 MN78-02 AHDM 	608700092 MN78-22 AHDM
--------------------	--------------------------------------	--------------------------------------	--------------------------------------	--------------------------------------

Snap-action system	608700085 MN78-S11 AHDM 	608700087 MN78-S20 AHDM 	608700089 MN78-S02 AHDM
--------------------	---------------------------------------	---------------------------------------	---------------------------------------

	4 NC	4 NO	3 NC / 1 NO	1 NC / 3 NO	1 NC / 1 NO overlapping
--	------	------	-------------	-------------	-------------------------

Slow-action system	608700093 MN78-40 AHDM 	608700094 MN78-04 AHDM 	608700095 MN78-31 AHDM 	608700096 MN78-13 AHDM 	608700091 MN78-V11 AHDM
--------------------	--------------------------------------	--------------------------------------	--------------------------------------	--------------------------------------	---------------------------------------

ACTUATORS IN73, MN78

Here is a small selection of our actuators. Others are available on request.

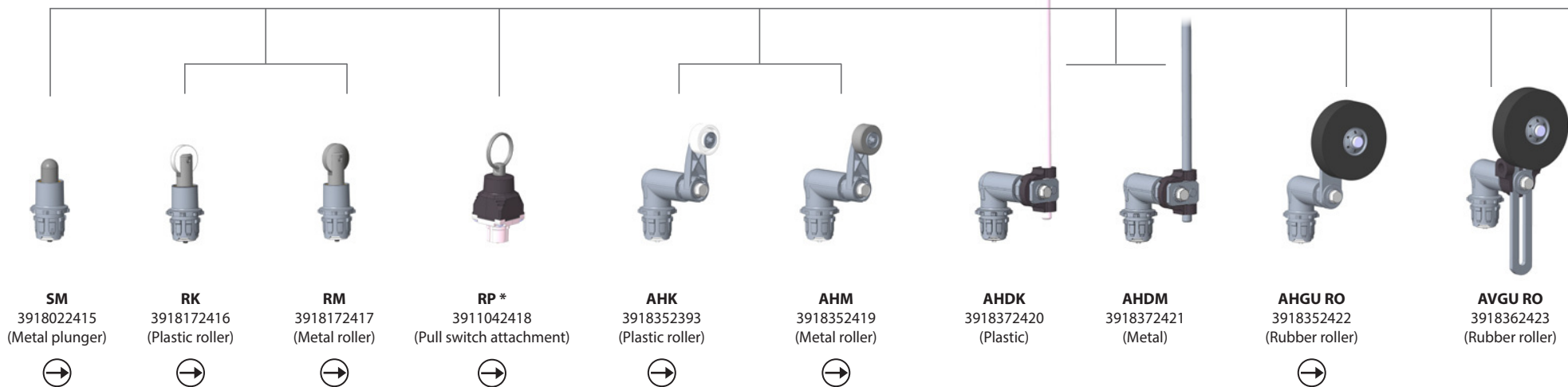

IN73 partially assembled with a switching unit and M20-threaded connection or with switching system and M12 plug

		1 NC / 1 NO	2 NC	2 NO	2 NC / 2 NO
Slow-action system	M20	6081000113 IN73-11 M20	6081000115 IN73-20 M20	6081000117 IN73-02 M20	6081000119 IN73-22 M20
	M12	6081000126 IN73-11 03	6081000128 IN73-20 03	6081000130 IN73-02 03	6081000132 IN73-22 05
Snap-action system	M20	6081000112 IN73-S11 M20	6081000114 IN73-S20 M20	6081000116 IN73-S02 M20	
	M12	6081000125 IN73-S11 03	6081000127 IN73-S20 03	6081000129 IN73-S02 03	

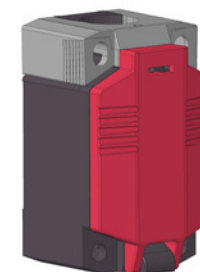

		4 NC	4 NO	3 NC / 1 NO	1 NC / 3 NO	1 NC / 1 NO overlapping
Slow-action system	M20	6081000120 IN73-40 M20	6081000121 IN73-04 M20	6081000122 IN73-31 M20	6081000123 IN73-13 M20	6081000118 IN73-V11 M20
	M12	6081000133 IN73-40 05	6081000134 IN73-04 05	6081000135 IN73-31 05	6081000136 IN73-13 05	6081000131 IN73-V11 03

* Can only be used with slow-action systems.

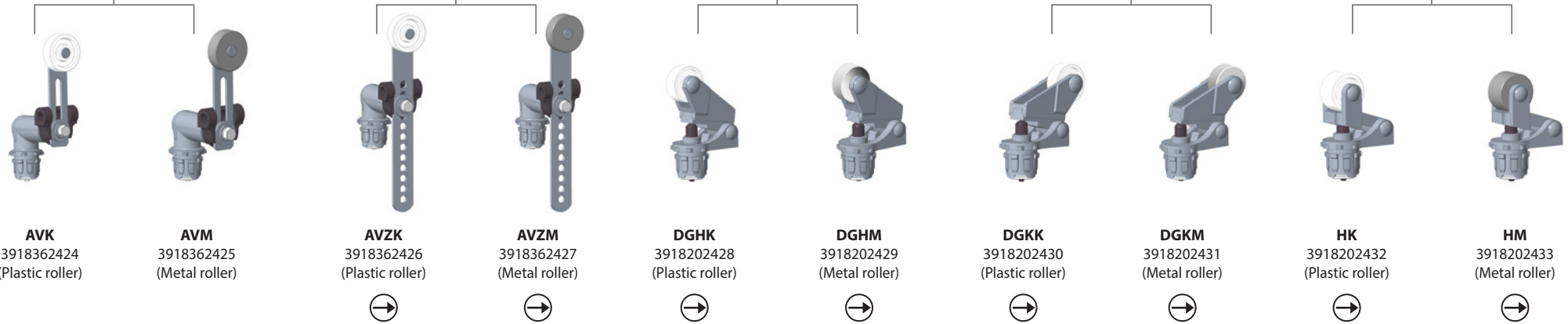

MN78 partially assembled with a switching unit and M20-threaded connection or with switching system and M12 plug

		1 NC / 1 NO	2 NC	2 NO	2 NC / 2 NO
Slow-action system	M20	6087000103 MN78-11 M20	6087000105 MN78-20 M20	6087000107 MN78-02 M20	6087000109 MN78-22 M20
	M12	6087000115 * MN78-11 04	6087000117 * MN78-20 04	6087000119 * MN78-02 04	6087000121 * MN78-22 05
Snap-action system	M20	6087000102 MN78-S11 M20	6087000104 MN78-S20 M20	6087000106 MN78-S02 M20	
	M12	6087000114 * MN78-S11 04	6087000116 * MN78-S20 04	6087000118 * MN78-S02 04	

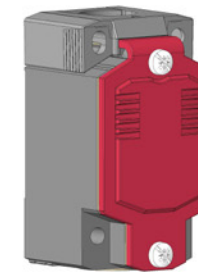

		4 NC	4 NO	3 NC / 1 NO	1 NC / 3 NO	1 NC / 1 NO overlapping
Slow-action system	M20	6087000110 MN78-40 M20	6087000111 MN78-04 M20	6087000112 MN78-31 M20	6087000113 MN78-13 M2	6087000108 MN78-V11 M20
	M12	6087000122 * MN78-40 05	6087000123 * MN78-04 05	6087000124 * MN78-31 05	6087000125 * MN78-13 05	6087000120 * MN78-V11 04

Metal enclosure

Position switches Metal GC



Product characteristics

- Protection class IP65 conforming to VDE 0470 T1
- Enclosure: Die-cast aluminium
- Cover: Sheet aluminium
- Actuator can be repositioned by 4 x 90°
- Cable entry M20 x 1.5
- Connection designation conforming to DIN EN 50013
- Metal actuators for high loads
- Graduated adjustment of the AH lever
- Selectable direction-dependent contact-making of the AH actuator (basic setting: contact-making on both sides)

Good to know ...

Thanks to its compact design, this metal-enclosed switch is ideally suited for virtually all safety and position monitoring applications.

Options

- Customised cables and connectors available on request

Technical data

Electrical data		
Design insulation voltage (up to) ^①	U _i max.	400 V AC
Conventional thermoelectric current (up to) ^①	I _{the}	10 A
Rated operating voltage	U _e max.	240 V
Utilisation category (up to) ^①		AC-15, U _e /I _e 240 V/3 A
Short circuit protection (up to) ^①		Safety fuse 10 A gL/gG
Protection class		I
Mechanical data		
Enclosure material		Die-cast aluminium
Ambient temperature		-30 °C to + 80 °C
Mechanical lifetime (up to) ^①		10 x 10 ⁶ switching cycles
B10d (up to) ^①		20 million
Switching frequency		≤ 100/min.
Type of connection		Screwed connections
Conductor cross-sections		Single-wire 0.5 – 1.5 mm ² or strand with wire-end ferrule 0.5 – 1.5 mm ²
Cable entry		1 x M20 x 1.5
Protection class		IP65 conforming to IEC/EN 60529
Standards		
VDE 0660 T100, DIN EN 60947-1, IEC 60947-1		
VDE 0660 T200, DIN EN 60947-5-1, IEC 60947-5-1		

^① Depending on switching system

Technical design

- Slow- and snap action
- **Versions:** 1 NC/1 NO, 2 NC/2 NO, 2 NC, overlapping contacts
- All NC contacts with ⊕ in the circuit diagram are positively opening contacts
- Type: Zb (galvanically isolated changeover contact)
- Latching function available on request

Mounting

- 2 M4 oval holes for adjustment
(for safety applications there is a blind hole for a Ø 4.0 mm fitted pin in the enclosure base or an enclosure with holes for M5)



POSITION SWITCHES METAL GC

GC-... IW

Replacement actuator: 3912020520

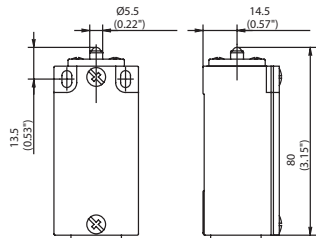

	1 NC / 1 NO	2 NC
--	-------------	------

Slow-action system

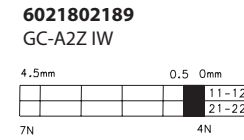
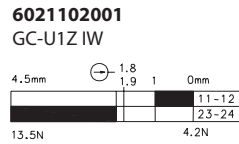

Snap-action system

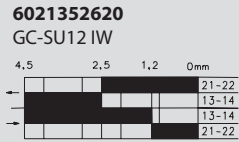

Special features: on request

GC-... STIW

Replacement actuator: 3912050523

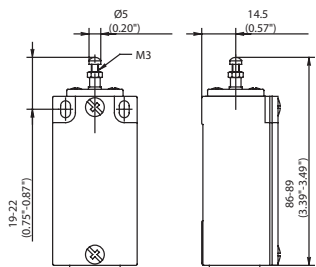

	1 NC / 1 NO	1 NC / 1 NO overlapping
--	-------------	-------------------------

Slow-action system

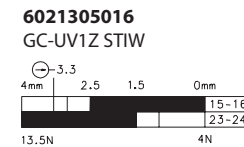
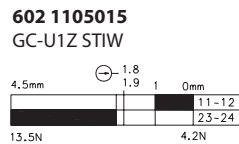

Snap-action system

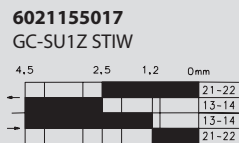

Special feature: Actuator length adjustable with adjusting screw



Replacement actuator: 3912170518

GC... RIW

	1 NC / 1 NO	2 NC	1 NC / 1 NO overlapping
Slow-action system	6021117029 GC-U1Z RIW 	6021817172 GC-A2Z RIW 	6021317030 GC-UV1Z RIW
Snap-action system	6021367626 GC-SU1Z RIW 		

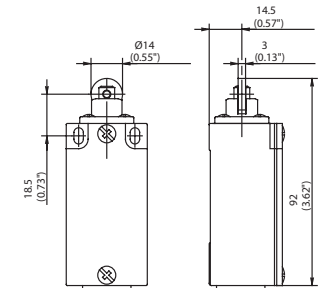

Special features (on request): available for high temperature range and the following contacts: 2 NC / 1 NO; 2 NC / 2 NO (larger enclosure)



Replacement actuator: 3912350722

GC... AH

	1 NC / 1 NO	2 NC	2 NO	1 NC / 1 NO overlapping
Slow-action system	6021135102 GC-U1Z AH 	6121835833 siehe gesondertes GC-A2Z AHS Datenblatt 	6021835160 GC-E2 AH 	6021335133 GC-UV1Z AH
Snap-action system	6021385634 GC-SU1Z AH 			

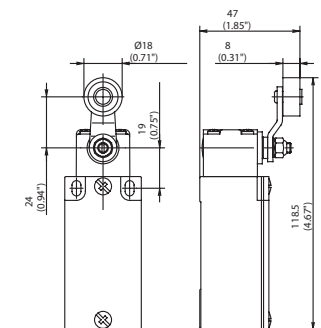

Special feature (on request): available with various roller diameters, cranked or straight lever and with various lever lengths with roller over switch and with the following contacts: 2 NC / 2 NO (larger enclosure)



Replacement actuator: 3912200552

GC... HIW

	1 NC / 1 NO	2 NC	2 NO	1 NC / 1 NO overlapping
Slow-action system	6021120057 GC-U1Z HIW 	6021820175 GC-A2Z HIW 	6021820157 GC-E2 HIW 	6021320058 GC-UV1Z HIW
Snap-action system	6021370629 GC-SU1Z HIW 			

Special features (on request): available with different actuating directions; available with a steel roller; with the following contacts: 2 NC / 2 NO; 1 NC / 2 NO with overlap (larger enclosure)

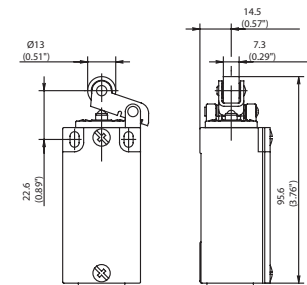

Replacement actuator: 3912400510

GC... FF

	1 NC / 1 NO
Slow-action system	6021140476 GC-U1 FF
Snap-action system	6021190100 GC-SU1 FF

Special features (on request): different spring lengths; different spring versions or spring rod

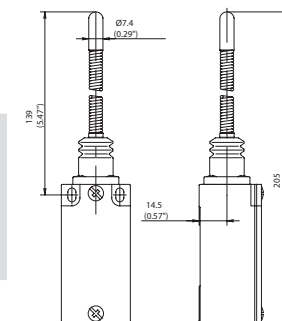

POSITION SWITCHES METAL GC

GC-... AF

Replacement actuator: 3912390725



1 NC / 1 NO

Slow-action system

6021139106
GC-U1 AF

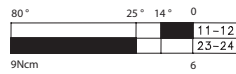

Snap-action system

6021189128
GC-SU1 AF

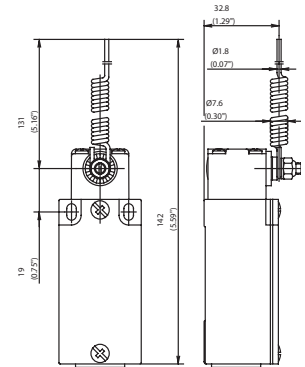
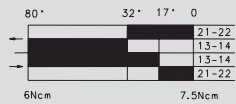

Special features (on request): available with various actuator lengths and actuator directions

GC-... DR

Replacement actuator: 3912410593



1 NC / 1 NO

Snap-action system

6021191099
GC-SU1Z DR

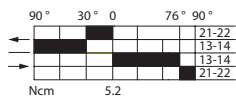

Special features (on request)

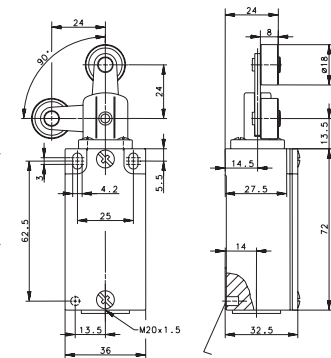

Notes

Diagrams. Sketches. Ideas.

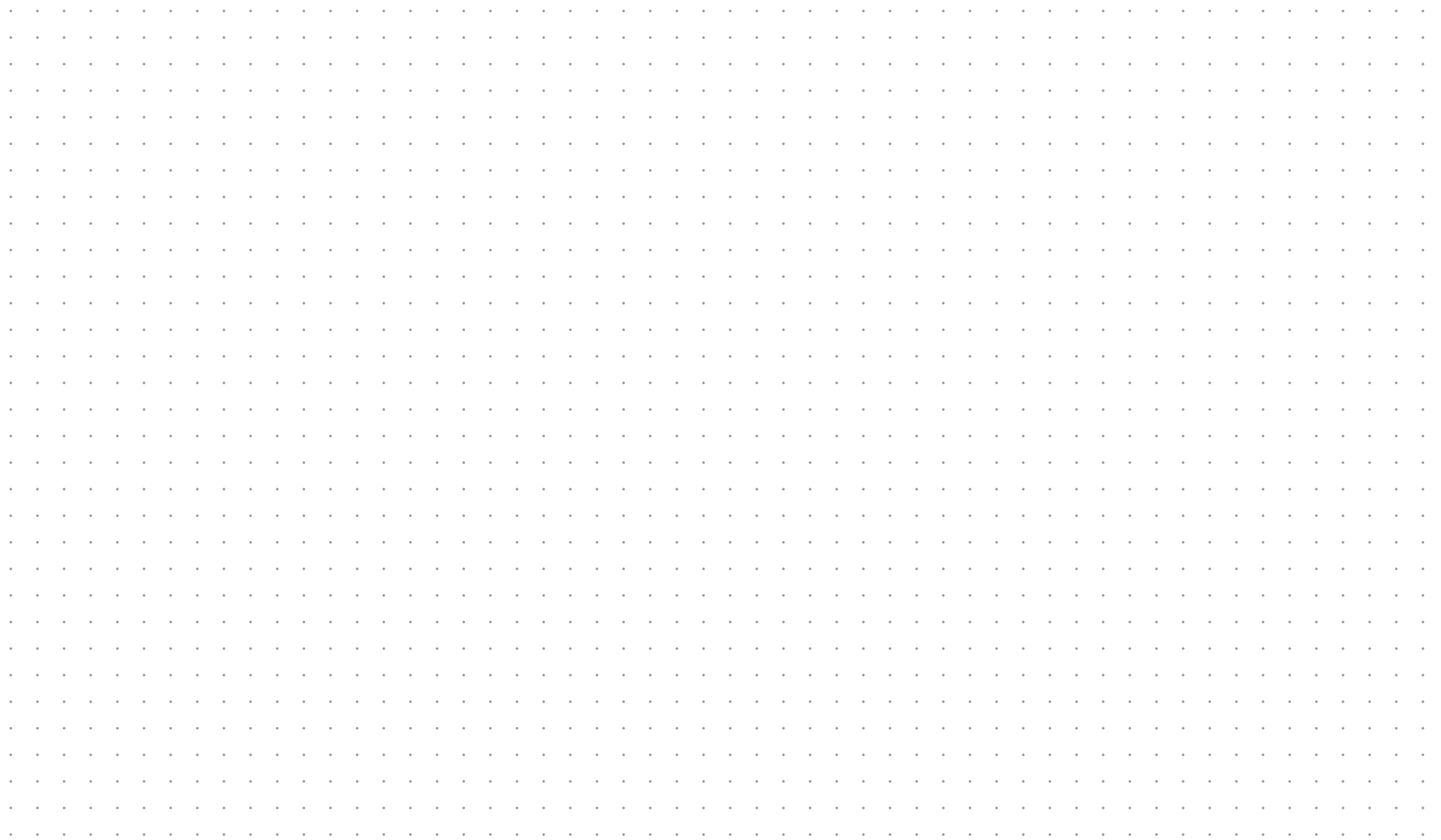

Metal enclosure

Position switches Metal SN2



Product characteristics

- Protection class IP65 conforming to VDE 0470 T1
- Enclosure: Die-cast aluminium
- Cover: Sheet aluminium
- Actuator can be repositioned by 4 x 90°
- Cable entry 3 x M20 x 1.5
- Connection designation conforming to DIN EN 50013
- Metal actuators for high loads
- Graduated adjustment of the AH lever
- Selectable direction-dependent contact-making of the AH actuator (basic setting: contact-making on both sides)

Good to know ...

With its three cable entries and spacious connection area, the SN2 limit switch is the optimum solution for through-wiring or even for branching off electrical circuits.

Options

- Customised cables and connectors are available on request

Technical design

- Slow- and snap action
- **Versions:** 1 NC/1 NO, 2 NC
- All NC contacts with \ominus in the circuit diagram are positively opening contacts
- Type: Zb (galvanically isolated changeover contact)
- Latching function available on request

Technical data

Electrical data		
Design insulation voltage	U_i max.	400 V AC
Conventional thermoelectric current	I_{the}	10 A
Rated operating voltage	U_e max.	240 V
Utilisation category		AC-15, A300, U_e/I_e 240 V/3 A
Short circuit protection (up to) ^①		Safety fuse 10 A gL/gG
Protection class		I
Mechanical data		
Enclosure material		Die-cast aluminium
Ambient temperature		-30 °C to + 80 °C
Mechanical lifetime		10 x 10 ⁶ switching cycles
B10d (up to) ^①		20 million
Switching frequency		max. 100/min.
Type of connection		Screwed connections
Conductor cross-sections		Single-wire 0.5 – 1.5 mm ² or strand with wire-end ferrule 0.5 – 1.5 mm ²
Cable entry		3 x M20 x 1.5
Protection class		IP65 conforming to EN 60529, DIN VDE 0470 T1
Standards		
conforms to EN 60947-1; EN 60947-5-1		
① Depending on switching system		

Mounting

- 2 M5 oval holes for adjustment
- 2 additional holes for M5 mounting screws in safety applications

Installation advantages

- 3 cable entries for through-wiring
- Generously dimensioned connection space
- Screw connections with self-lifting clamping plates
- Easy-to-change switching system thanks to snap-in retainer
- Finely adjustable switching point with adjusting screw

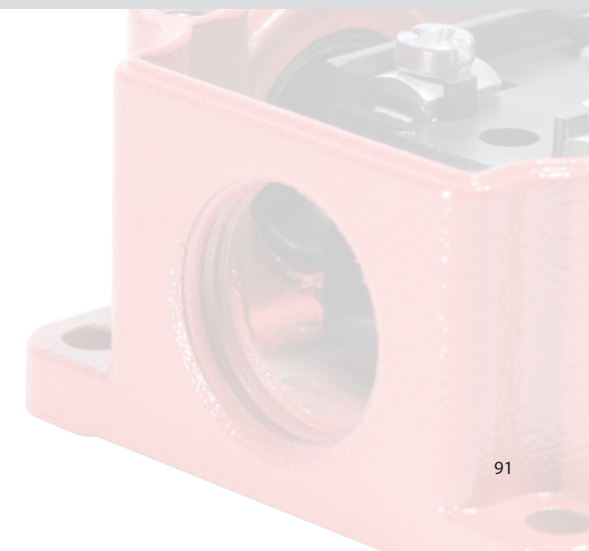
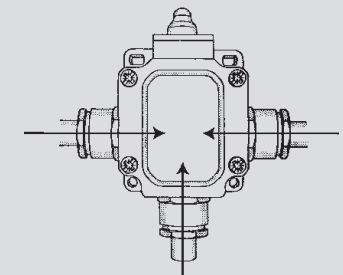

POSITION SWITCHES METAL SN2

SN2-... W



1 NC / 1 NO

Slow-action system

6033103023
SN2-U1Z W

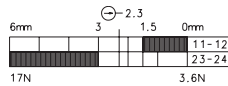

Snap-action system

6033353016
SN2-SU1Z W

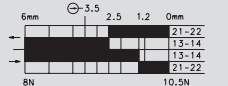

Special features (on request)

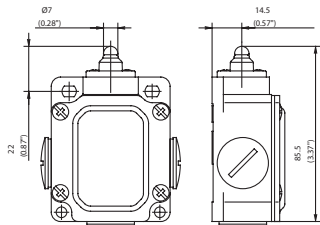

SN2-... RIW

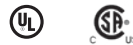

1 NC / 1 NO

Slow-action system

6033117025
SN2-U1Z RIW

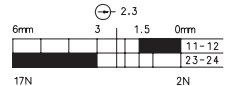

Snap-action system

6033367017
SN2-SU1Z RIW

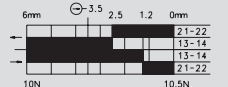

Special feature (on request): available with different actuating directions; with latching function

Replacement actuator: 3918170587

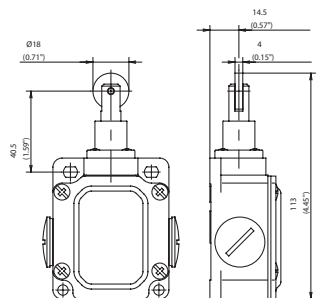

SN2-... LIW



1 NC / 1 NO

Snap-action system

6033194022
SN2-SU1 LIW

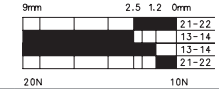

Special feature: Telescopic plunger, particularly long actuation travel of 9 mm

Replacement actuator: 3912440536

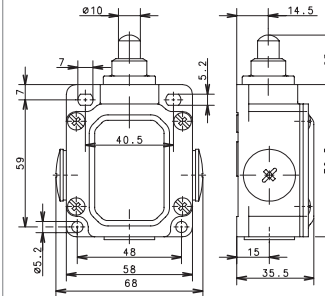

SN2-... AHS



1 NC / 1 NO

Slow-action system

6033135002
SN2-U1Z AHS

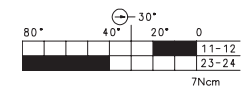

Snap-action system

6033385018
SN2-SU1Z AHS

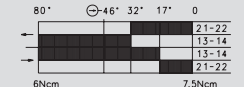

Special feature (on request): available with different actuating directions

Replacement actuator: 3913351913

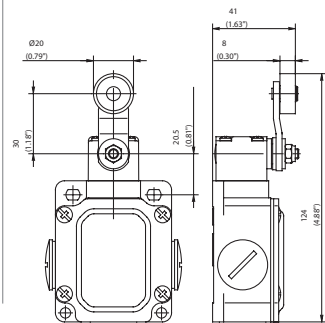

SN2-... DGHW



1 NC / 1 NO

Slow-action system

6033121005
SN2-U1Z DGHW

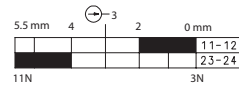

Snap-action system

6033371004
SN2-SU1Z DGHW



Special feature (on request): available with different actuating directions

Replacement actuator: 3918211656

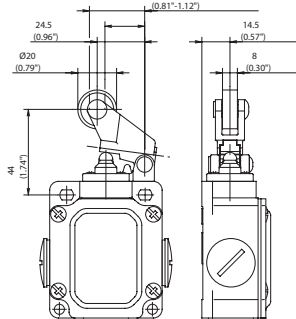

SN2-... HW



1 NC / 1 NO

Slow-action system

6033121007
SN2-U1Z HW

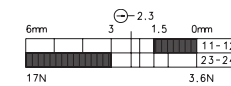

Snap-action system

6033371006
SN2-SU1Z HW

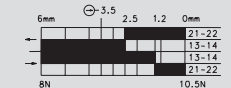

Special feature (on request): available with different actuating directions

Replacement actuator: 3913210553

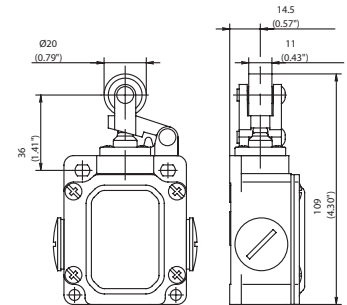

SN2-... DGKW



1 NC / 1 NO

Slow-action system

6033377011
SN2-SU1Z DGKW

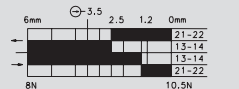

Special feature (on request): available with different actuating directions

Replacement actuator: 3918271655

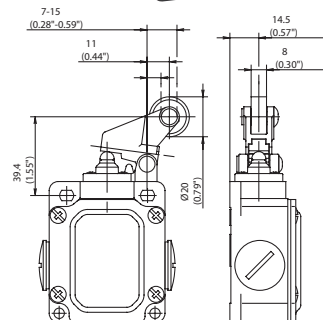

SN2-... AD4K

2 NC

Snap-action system

6133887022
SN2-SA2Z AD4K

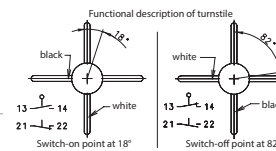

Special feature (on request)

Replacement actuator: **3913371712**

without screws, without seals

3992000042

accessory bag (40 screws, 10 seals)

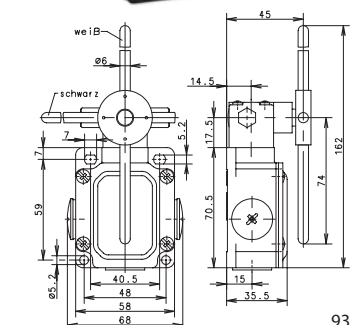

Metal enclosure

Position switches Metal D



Product characteristics

- Protection class IP65 according to VDE 0470 T1
- Enclosure: Die-cast aluminium
- Cover: Sheet aluminium
- Actuator rotatable by 4 x 90° (depending on type)
- Cable entries 2 x M20 x 1.5
- Connection designation conforming to DIN EN 50013
- Sturdy contacts
- Hard wearing guide bushes

Good to know ...

Heavy duty enclosure for harsh operating conditions with a particularly tough design of the actuator and switching systems.

Technical design

- Slow- and snap action
- **Versions:** 1 NC/1 NO, 2 NC, 2 NO, 3 NC, 3 NO, overlapping contacts
- All NC contacts with \ominus in the circuit diagram are positively opening contacts
- Latching function available on request

Technical data

Electrical data		
Design insulation voltage	U_i max.	400 V AC
Conventional thermoelectric current (up to) ^①	I_{the}	10 A
Rated operating voltage	U_e max.	240 V
Utilisation category		AC-15, U_e/I_e 240 V/3 A
Short circuit protection (up to) ^①		Safety fuse 10 A gL/gG
Protection class		I
Mechanical data		
Enclosure material		Die-cast aluminium
Ambient temperature		-30 °C to + 80 °C
Mechanical lifetime		10 x 10 ⁶ switching cycles
B10d		20 million
Switching frequency		≤ 100/min.
Type of connection		Screwed connections
Conductor cross-sections		Single-wire 0.5 – 1.5 mm ² or strand with wire-end ferrule 0.5 – 1.5 mm ²
Cable entry		2 x M20 x 1.5
Protection class		IP65 conforming to IEC/EN 60529
Standards		
VDE 0660 T100, DIN EN 60947-1, IEC 60947-1		
VDE 0660 T200, DIN EN 60947-5-1, IEC 60947-5-1		

^① Depending on switching system

Mounting

- 4 M5 oval holes

Options

- Customised cables and connectors are available on request

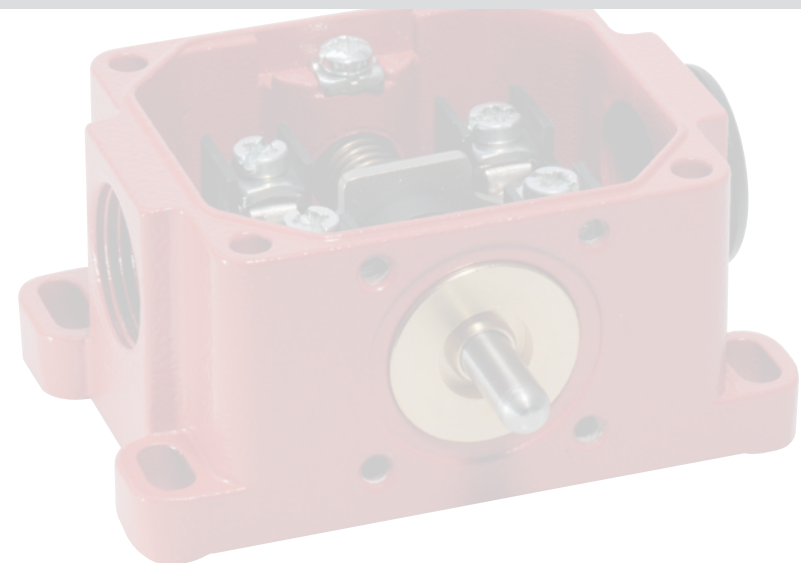

POSITION SWITCHES METAL D

D-... W



	1 NC / 1 NO	2 NC	2 NO	1 NC / 1 NO overlapping
--	-------------	------	------	-------------------------

Slow-action system

6041103002
D-U1 W

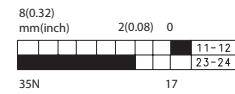

6041803090
D-A2 W

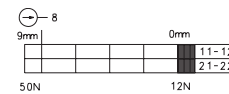

6041803046
D-E2 W

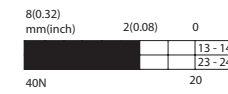

6041303134
D-UV1Z W

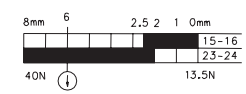

Snap-action system

6041153156
D-SU1 W

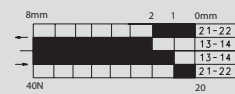

Special feature (on request):

Also available with the following contacts: 3 NC, 3 NO, 2 NC / 2 NO (larger enclosure)

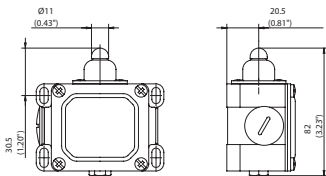

D-... RW



	1 NC / 1 NO	2 NC	2 NO	1 NC / 1 NO overlapping
--	-------------	------	------	-------------------------

Slow-action system

6041118229
D-U1Z RW

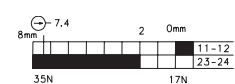

6041818741
D-A2Z RW

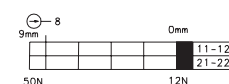

6041818052
D-E2 RW

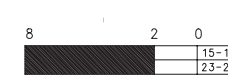

6041318140
D-UV1Z RW

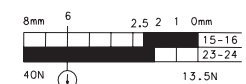

Snap-action system

6041168162
D-SU1 RW

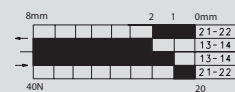

Special feature (on request):

Available for high temperature range
With the following contacts: 3 NC, 3 NO, 2 NC / 2 NO (larger enclosure)

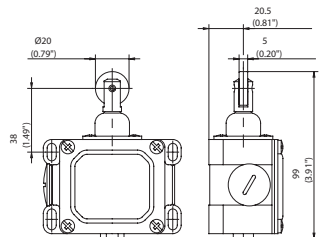



Replacement actuator: 3914350924

D-... AH

	1 NC / 1 NO	2 NC
--	-------------	------

Slow-action system

6041135019
D-U1 AH

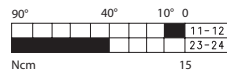

6041835107
D-A2 AH

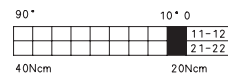

Snap-action system

6041185173
D-SU1 AH

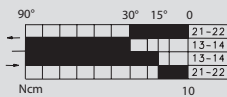

Special feature (on request):

with steel roller, various roller diameters; cranked or straight lever; different lever lengths
Also available with the following contacts: 3 NC; 2 NC / 2 NO

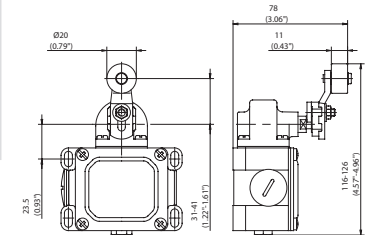

Replacement actuator: 3914211065

D-... HW

	1 NC / 1 NO	1 NC / 1 NO overlapping
--	-------------	-------------------------

Slow-action system

6041121010
D-U1 HW

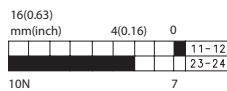

6041321142
D-UV1Z HW

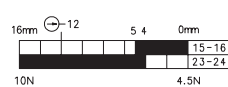

Snap-action system

6041171164
D-SU1 HW

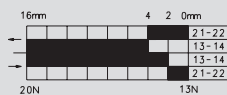

Special feature (on request):

Available for high temperature range
Also available with the following contacts: 3 NC, 2 NC / 2 NO (larger enclosure)

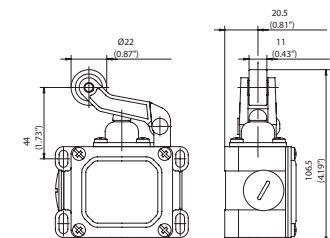

POSITION SWITCHES METAL D



D-... PW

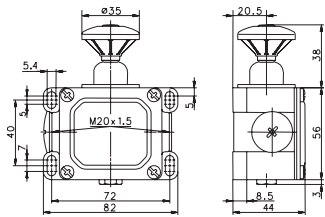

	1 NC / 1 NO	2 NC
--	-------------	------

Slow-action system	6041113006 D-U1 PW	6041813835 D-A2Z PW
	<p>8mm 2 0-1.2mm 11-12 23-24 35N 17N</p>	<p>9mm 0mm 11-12 21-22 50N 12N</p>

Special feature (on request): Also available with the following contacts: 3 NC, 3 NO, 2 NC / 2 NO (larger enclosure)

Position switches

Accessories

Finger guard



The Finger guard helps to prevent the user from receiving an electric shock.

Product range

Article number	Series
3595900060	Bi2

Guide element



The guide element provides additional support to the rear of the switches IN62 / IN65 / I81.

Product range

Article number	Series
3515900209	IN62 / IN65 / I81

Mounting plate, control cabinet



The mounting plate allows IN62 / IN65 / I81 switches to be din rail mounted in control enclosures.

Product range

Article number	Series
3595900087	IN62 / IN65

Sealed cable gland



Product range

Article number	Series
3998000120	M16
3998000121	M20

NPT adapter M16 on 1/2" (NPT 14)



Product range

Article number	Series
3998000115	various families

NPT adapter M20 on 1/2" (NPT 14)



Product range

Article number	Series
3998000116	various families

LED Cover



Product range

Article number	Series
3908031788	IN62 / IN65

POSITION SENSORS



INDUCTIVE SENSORS

110 Standard range

140 NAMUR sensors

144 AC sensors

148 Analogue sensors

150 ATEX sensors

CAPACITIVE SENSORS

156 Standard range

168 NAMUR sensors

MAGNETIC SENSORS

170 Electromechanical magnetic sensors

192 Electronic magnetic sensors

200 Cylinder sensors

204 ATEX sensors

ACCESSORIES

208 Magnets

218 Mounting brackets, Snap-In connectors

220 Connectors

224 Type Code

POSITION SENSORS

Functional principle of the sensor system

A sensor detects non-electrical physical quantities without contact and converts them into electrical quantities like currents or voltages. In this field, BERNSTEIN concentrates on inductive, capacitive and magnetic proximity switches.

Inductive Sensors

An inductive proximity switch detects metallic objects and consists of four functional groups: a coil, an oscillator, a threshold switch and a switching output stage.

The oscillator generates a high-frequency alternating magnetic field that exits the coil at the active surface. When a metal object enters this field, eddy currents are induced in it. These eddy currents draw energy from the magnetic field and thus from the oscillator; it is damped. The energy withdrawal is greater the closer the metal object is brought to the active surface. The threshold value switch switches on the switching output stage at a defined value of damping.

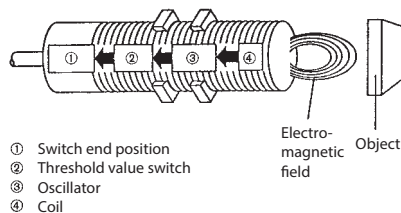

Capacitive Sensors

Capacitive proximity switches detect conductive and non-conductive materials in a solid or liquid state. The sensors consist of 4 functional groups: a sensor electrode, an oscillator, a threshold value switch and a switching output stage.

The sensor electrode, which is located behind the active surface, forms a capacitor with an actuating medium in combination with mass. An approximate medium increases the capacitance, which is why the RC oscillator begins to oscillate. The capacitance value required for oscillation can be determined by changing the amplification of the oscillator with a potentiometer. In this way, the response sensitivity/switching distance to the medium can be adjusted. The oscillator output signal is fed to an evaluation circuit which controls the respective switching amplifier.

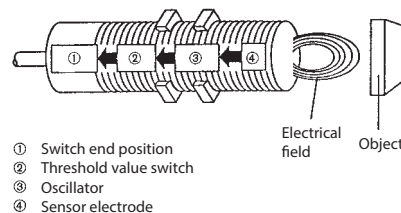

Electromechanical magnetic switches

Electromechanical magnetic switches detect electro- and permanent magnets. Basic elements of these magnetic switches are reed contacts which change their electrical behaviour by approaching the actuating magnet. Under the influence of a magnetic field, the contact paddles assume an opposite polarity (south and north pole). Approaching or removing a magnet causes the contact paddles to close or open. The sensitivity of the switch and the field strength of the magnet determine the switching distance.

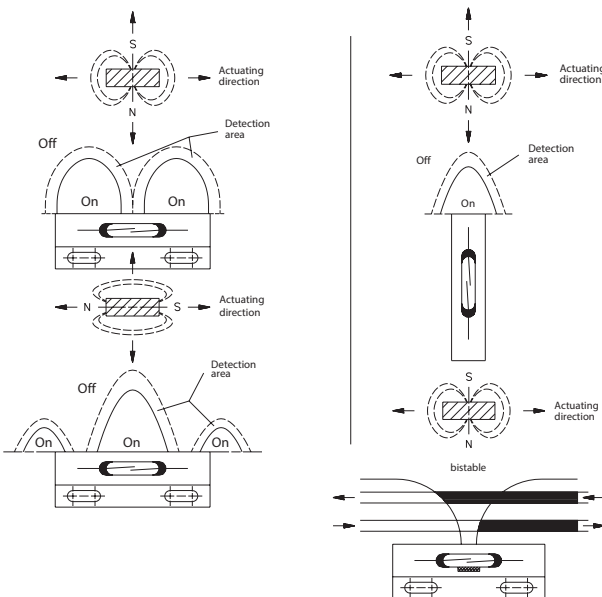

Electronic Magnetic Sensors

Magnetic switches with magnetoresistive elements or Hall elements detect an actuating magnet without contact. Magnetoresistive sensors react with an increase in resistance, while Hall elements generate a voltage when a magnetic field passes through them. With high switching frequencies and switching distances, as well as vibration resistance, the sensors are a good alternative to electromechanical sensors for challenging applications.

Speed sensors:

Are electronic magnetic sensors with Hall elements, which detect the rotation of ferromagnetic gears with switching distances of up to 2 mm. The high user-friendliness of Hall sensor technology is also fully effective here: high switching frequencies and insensitivity to shock impact.

Cylinder sensors

The sensors are based on the operating principles of magnetic sensors. They are defined by their design, which can be used in all common T and C profiles (e.g. type FESTO or SMC) or in space-saving applications. For this reason, they are often used for checking pneumatic cylinders.

For applications without changing the switching point, fixed sensors can be used. For this purpose, BERNSTEIN offers Hall sensors with adjusted sensitivity or reed contact versions which operate without auxiliary power.

For flexible use, sensors are also offered which permit one or two freely programmable and independent switching points, as well as IO-Link sensors which permit an analog output between two teach-in end positions.

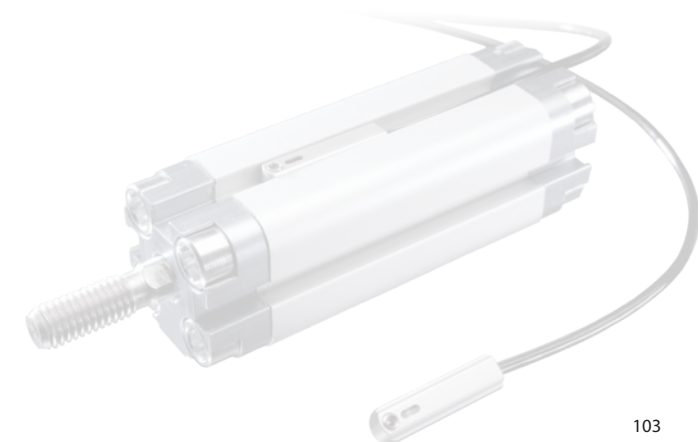

POSITION SENSORS

Technology Overview

NEW IO-Link

IO-Link is a manufacturer-independent, standardized communication interface. It enables continuous communication from the sensor to the controller. With a “wake-up command”, the single-switching sensor becomes an IO-Link device. Bidirectional data packets are exchanged via the point-to-point connection, whereby not only the switching signal is transmitted, but also parameter, diagnostic and communication data.

In IO-Link mode, the switching distance and the switching function can be configured, among other things. The sensor can then be operated in IO-Link mode or in standard input/output mode (SIO mode).

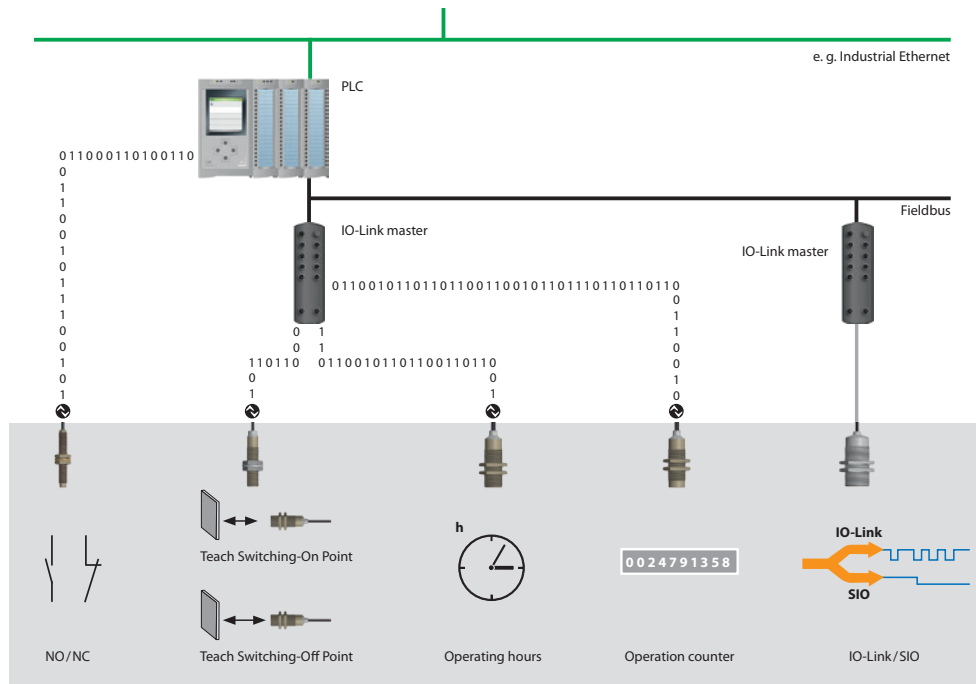

AC-2 Wire

These 2-wire sensors are used in applications where AC loads need to be switched. Instead of transistors, thyristors are used as switching output stages.

Analog output

The inductive analogue sensors do not switch at a defined switching point, but instead output an assigned output signal in accordance with their specific characteristic curve at a defined switching distance. Sensors with voltage or current output are commonly used.

Namur

Standard Namur sensors are DC 2-wire devices consisting of a coil and an oscillator. They change their current consumption depending on the object distance. BERNSTEIN has built on this and also offers sensors that switch at a defined value.

POSITION SENSORS

Basic information

PNP output / Source output

With the source output the load is connected between the switching output and V-. The current flows at Switch V+ through the transistor and then through the load to ground.

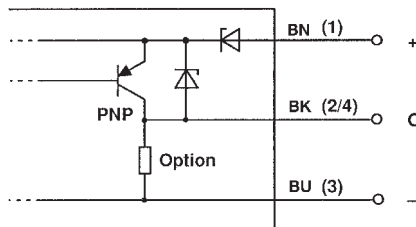

NPN output / Sink output

With the sink output, the load is connected between the switching output and V+. The current flows at Switching from V+ via the load and then through the transistor to V-.

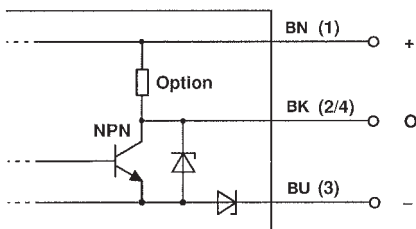

Normally-open contact



When the target enters the detection area, the load current flows. When the target is removed from the detection zone, the circuit is interrupted.

Normally-closed contact



If the target enters the detection area, the circuit is broken. When the target is removed from the detection area, the load current flows again.

Changeover contact



Is a combination of the normally open and normally closed function. When the target enters the detection zone, both elements change their state.

Bistable

These magnetic sensors have integrated bias magnets which keep the contacts closed or pre-tension them. The contacts remain in their switching position until an oppositely polarised stronger magnet cancels the pretensioning.

POSITION SENSORS

Basic information

Sensing distance

Refers to the distance between target and sensor when approaching causes a signal change at the output.

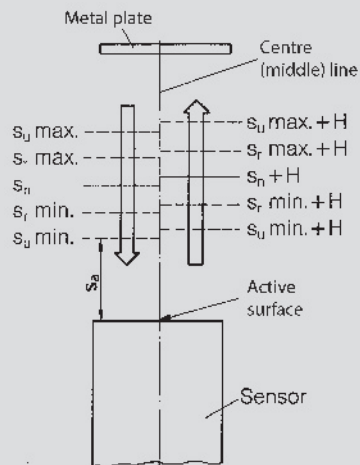

Nominal sensing distance (S_n)

The switching distance does not take into account manufacturing tolerances or changes due to external influences.

Real sensing distance (S_r)

This distance is the effective operating distance measured at nominal voltage and nominal temperature. For inductive and capacitive proximity switches, it must be between 90 % - 110 % of the rated operating distance.

Useable sensing distance (S_u)

The measurement of this switching distance takes place within the permissible temperature and voltage ranges. The distance must be between 90 % and 110 % of the real switching distance for inductive sensors and between 80 % and 120 % of the real switching distance for capacitive sensors.

Assured switching distance (S_a)

The distance from the active surface, which ensures switching under the influence of the permissible operating conditions. For inductive proximity switches, the distance must be between 0 % and 81 %, and for capacitive proximity switches between 0 % and 72 % of the rated switching distance.



Hysteresis

Refers to the difference between the switch-on point when an object approaches and the switch-off point when it is moved away. It is given as a percentage in relation to the nominal switching distance.

The hysteresis is necessary to prevent the output from fluttering when objects slowly approach each other due to external influences such as temperature changes, and to prevent electrical interference or vibration.

Response sensitivity

Capacitive sensors react to changes in the electric field. Therefore, depending on the dielectric constant of the object to be detected, different switching distances result. Capacitive sensors often allow the sensitivity to be adjusted with a potentiometer.

Reduction factors

The definition of the switching distance for inductive sensors is based on the measurement with a standardized steel measuring plate. If other materials with the same dimensions are used, the switching distance is reduced.

Switching frequency

Specifies the maximum number of switching cycles per second.

Repeatability

Is the maximum percentage change of the real switching distance when repeated actuation occurs under specified conditions.

Residual current

Indicates the current which flows through the load circuit in the unswitched state.

Voltage drop

Is the maximum voltage which is lost in the switched state via the component resistances of the sensor.

Lowest operating current

The minimum current required at the switching output to maintain the function of the sensor.

Idle current

Is the intrinsic current of a 3-/4-wire proximity switch without a load being connected.

Ready delay

Period between the application of the supply voltage and the time at which the switching output assumes the switching state.

Short-circuit protection

The circuit arrangement protects the sensor from destruction in the event of a short circuit. The output is blocked and the status is interrogated in a clocked manner. Once the short-circuit is removed, the sensor resumes operation.

Reverse polarity protection

If the supply voltage is reversed, the Proximity switch is protected against destruction.



POSITION SENSORS

Basic information

Overload protection

The sensors are protected against destruction by overload. The output is blocked and the status is interrogated in a clogged manner. If the overload is removed, the sensor resumes operation.

Pickup delay

Is a time function integrated in the sensor, which delays the switching of the output when an object is detected.

Dropout delay

Is a time function integrated in the sensor which delays the switching of the output when an object leaves the active field.

MTTF

Stands for "mean time to failure" and means the average time until a failure. This information is used for the reliability prognosis and predicts a statistical period until failure.

Non-flush

Inductive sensors must have a free zone with the following meet criteria:

- parallel to the active surface, a free zone at a distance of $\geq 3 \times$ rated switching distance
- laterally to the active surface, a free zone at a distance of $\geq 1 \times$ housing diameter
- free zone of a depth to the active surface $\geq 2 \times$ rated switching distance

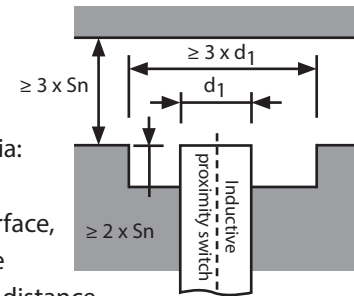

Capacitive sensors must maintain a free zone with the following criteria:

- parallel to the active surface, a free zone at a distance of $\geq 3 \times$ rated switching distance
- laterally to the active surface, a free zone at a distance of $\geq 3 \times$ housing diameter
- free zone of a depth to the active surface $\geq 3 \times$ rated switching distance

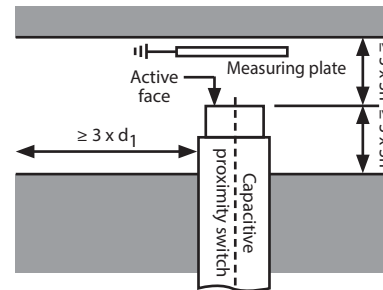

Flush

- with flush sensors, the active surface can be flush with a metal surface without being influenced.

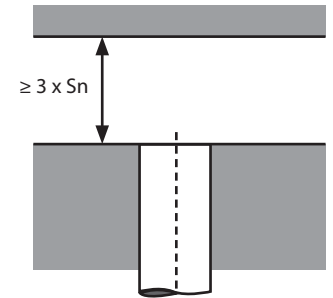

ATEX-Sensors

Protection against ignitable energies is achieved by encapsulation in the case of magnetic switches and by the principle of intrinsic safety in the case of inductive NAMUR sensors. The magnetic switches offer solutions for zones 1, 2, 21, 22 (2G/2D) and the inductive sensors for zones 1, 2, 21, 22 (2G/2D/3G/3D). The sensors are provided with a connecting cable at the factory. This is inseparably connected to the housing and part of the required approval.



Definition of protection classes in accordance with DIN EN 60529

The protection class of an enclosed device denotes the degree of protection. The degree of protection includes the protection of persons against contact with parts under voltage and the protection of equipment against the infiltration of foreign bodies and water.

ISO 20653	DIN EN 60529	IP Protection classes International Protection
1. number		Protection against foreign bodies and contact
0	0	No protection
1	1	Protection against foreign bodies ≥ 50 mm/Access with the back of the hand
2	2	Protection against foreign bodies ≥ 12.5 mm/Access with one finger
3	3	Protection against foreign bodies ≥ 2.5 mm/Access with a tool
4	4	Protection against foreign bodies ≥ 1.0 mm/Access with a wire
5K	5	Protection against harmful amounts of dust/Access with a wire
6K	6	Dust proof/Protection against access with a wire

ISO 20653	DIN EN 60529	IP Protection classes International Protection
2. number		Protection against water
0	0	No protection
1	1	Protection against vertical dripping water
2	2	Protection against dripping water up to 15° inclination
3	3	Protection against spray water up to 60°
4	4	Protection against splash water
4K		Protection against splash water at elevated pressure
5	5	Protection against hose water
6	6	Protection against strong hose water
6K		Protection against strong hose water at elevated pressure
7	7	Protection against temporary immersion
8	8	Protection against permanent immersion
9K	9	Protection against steam jet cleaning/high jet water temperature

Inductive Sensors

Standard range



Product features

- Microsensors: Ø 3 mm – Ø 6 mm
- Metric types: M08 – M30
- Special types: smooth cylindrical, rectangular, square
- Sensing distance: 0.6 mm – 40 mm
- Switching function: NO contact, NC contact, Changeover contact
- Switching frequency: up to 3,000 Hz
- Enclosure material: stainless steel, brass and plastic enclosure

Good to know ...

A wide range of Ø 4 mm – M30 mm sensors are IO-Link capable. Take advantage of the flexibility, switching distances and switching functions to be optimally adapted to your specific plant.

The IO-Link can be found under inductive sensors at www.bernstein.eu

Reduction factors

The definition of the operating distance is based on the measurement with a standardized square measuring plate made of steel. If other materials with the same dimensions are used, the operating distance is reduced as shown in the diagram.

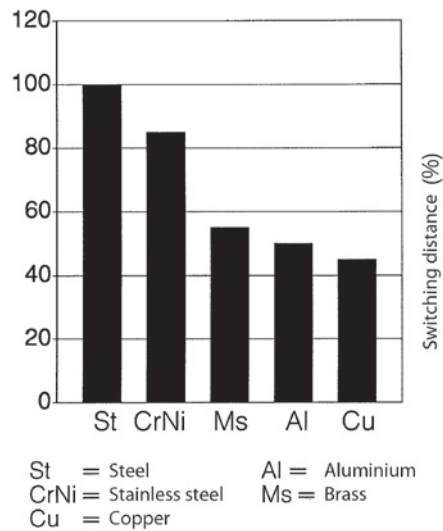

Options

- Cable and connector assembly
- Adaptation of the enclosures
- Product adaptations and modifications
- Customized development



INDUCTIVE SENSORS Type Ø 4 mm, Ø 6.5 mm



Type	Ø 4 mm	Ø 6.5 mm	Ø 6.5 mm	Ø 6.5 mm
Enclosure material	Stainless steel 1.4401	Stainless steel 1.4401	Stainless steel 1.4401	Stainless steel 1.4401
Type of installation	flush	flush	flush	flush
Nominal sensing distance	0.8 mm	1.5 mm	1.5 mm	1.5 mm
Type of connection	Cable 2 m	Cable 2 m	Connector M8	Cable 5 m
Special feature				Short type
PNP	DC	NO contact	6532999001 KIB-D04PS/001-KL2I	6502999010 KIB-D06PS/1,5-KL2
			6532799001 KIB-D04PÖ/001-KL2I	6502999012 KIB-D06PS/1,5-KLSM8
			6532399001 KIB-D04NS/001-KL2	6602999460 KIB-D06PS/1,5-KL5V
PNP	DC	NC contact		
NPN	DC	NO contact		
NPN	DC	NC contact		
Technical data				
Rated operating voltage range	U_B	10–30 VDC	10–36 VDC	10–36 VDC
Rated operating current	I_e	≤ 200 mA	≤ 200 mA	≤ 200 mA
Max. switching voltage	F	1000 Hz	1000 Hz	1000 Hz
Short circuit-protection		cyclic	cyclic	cyclic
Function/operating voltage indicator		LED/–	LED/–	LED/–
Mechanical data				
Ambient temperature (min/max)		–25°C/+70°C	–25°C/+70°C	–25°C/+70°C
Protection class in accordance with IEC 529, EN 60529		IP67	IP67	IP67
Connection		3 x 0.14	3 x 0.14 mm ²	M8 x 1 3 x 0.14 mm ²
Approvals				

= IO-Link

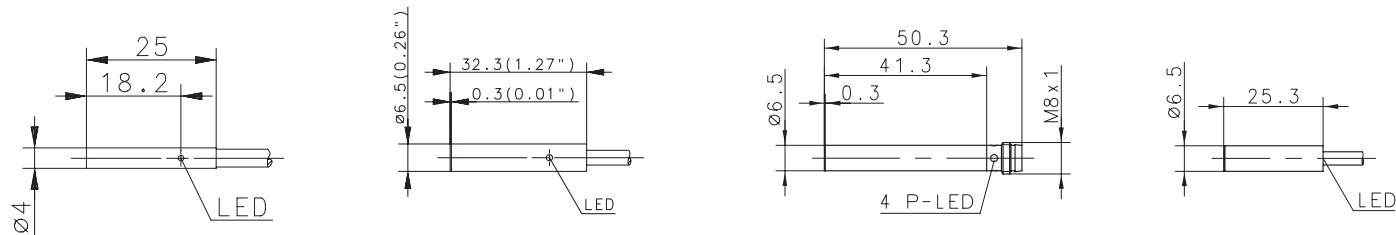

Cable couplings and other accessories can be found from p. 208

INDUCTIVE SENSORS Type Ø 6.5 mm



Type	Ø 6.5 mm		
Enclosure material	Stainless steel 1.4401		
Type of installation	non-flush		
Nominal sensing distance	2 mm		
Type of connection	Connector M8		
Special feature			
PNP	DC	NO contact	6502999013 KIN-D06PS/002-KLSM8
PNP	DC	NC contact	
NPN	DC	NO contact	
NPN	DC	NC contact	
Technical data			
Rated operating voltage range	U_B	10–36 VDC	
Rated operating current	I_e	≤ 200 mA	
Max. switching voltage	F	750 Hz	
Short circuit-protection	cyclic		
Function/operating voltage indicator	LED/–		
Mechanical data			
Ambient temperature (min/max)	–25°C/+70°C		
Protection class in accordance with IEC 529, EN 60529	IP67		
Connection	M8 x 1		
Approvals			

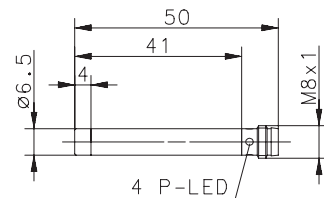

INDUCTIVE SENSORS Type M5



Type	M5		M5
Enclosure material	CuZn39Pb3		CuZn39Pb3
Type of installation	flush		flush
Nominal sensing distance	1 mm		1 mm
Type of connection	Cable 2m		Connector M8
Special feature			
PNP	DC	NO contact	6532999002 KIB-M05PS/001-KL2I
PNP	DC	NC contact	6532799002 KIB-M05PÖ/001-KL2I
NPN	DC	NO contact	6532399002 KIB-M05NS/001-KL2
NPN	DC	NC contact	6532199002 KIB-M05NÖ/001-KL2
NPN	DC	NO contact	6532999003 KIB-M05PS/001-KLSM8I
NPN	DC	NC contact	6532799003 KIB-M05PÖ/001-KLSM8I
NPN	DC	NO contact	6532399003 KIB-M05NS/001-KLSM8
NPN	DC	NC contact	6532199003 KIB-M05NÖ/001-KLSM8
Technical data			
Rated operating voltage range	U_B	10–30 VDC	10–30 VDC
Rated operating current	I_e	≤ 200 mA	≤ 200 mA
Max. switching voltage	F	1000 Hz	1000 Hz
Short circuit-protection		cyclic	cyclic
Function/operating voltage indicator		LED/–	LED/–
Mechanical data			
Ambient temperature (min/max)		–25°C/+70°C	–25°C/+70°C
Protection class in accordance with IEC 529, EN 60529		IP67	IP67
Connection		3 x 0.14 mm ²	M8 x 1
Approvals			

= IO-Link

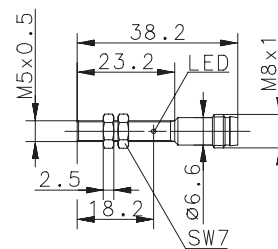
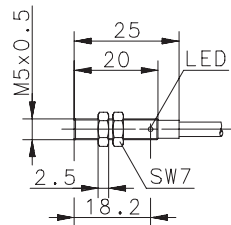

INDUCTIVE SENSORS Type M8



Type	M8	M8	M8	M8
Enclosure material	Stainless steel 1.4305	Stainless steel 1.4305	Stainless steel 1.4305	Stainless steel 1.4305
Type of installation	flush	flush	flush	flush
Nominal sensing distance	1 mm	1 mm	1 mm	1 mm
Type of connection	Cable 2 m	Cable 2 m	Connector M8	Connector M8
Special feature	Short type	Standard type	Short type	Standard type
PNP DC NO contact	6532901001 KIB-M08PS/001-KL2VI	6532902001 KIB-M08PS/001-KL2I	6532942001 KIB-M08PS/001-KLSM8VI	6532942003 KIB-M08PS/001-KLSM8I
PNP DC NC contact	6532701001 KIB-M08PÖ/001-KL2VI	6532702001 KIB-M08PÖ/001-KL2I	6532742001 KIB-M08PÖ/001-KLSM8VI	6532742003 KIB-M08PÖ/001-KLSM8I
NPN DC NO contact	6532301001 KIB-M08NS/001-KL2V	6532302001 KIB-M08NS/001-KL2	6532342001 KIB-M08NS/001-KLSM8V	6532342003 KIB-M08NS/001-KLSM8
NPN DC NC contact	6532101001 KIB-M08NÖ/001-KL2V	6532102001 KIB-M08NÖ/001-KL2	6532142001 KIB-M08NÖ/001-KLSM8V	6532142003 KIB-M08NÖ/001-KLSM8
Technical data				
Rated operating voltage range	U_B 10–30 VDC	10–30 VDC	10–30 VDC	10–30 VDC
Rated operating current	I_e ≤ 200 mA	≤ 200 mA	≤ 200 mA	≤ 200 mA
Max. switching voltage	F 1000 Hz	1000 Hz	1000 Hz	1000 Hz
Short circuit-protection	cyclic	cyclic	cyclic	cyclic
Function/operating voltage indicator	LED/–	LED/–	LED/–	LED/–
Mechanical data				
Ambient temperature (min/max)	–25°C/+70°C	–25°C/+70°C	–25°C/+70°C	–25°C/+70°C
Protection class in accordance with IEC 529, EN 60529	IP67	IP67	IP67	IP67
Connection	3 x 0.14 mm ²	3 x 0.14 mm ²	M8 x 1	M8 x 1
Approvals				

= IO-Link

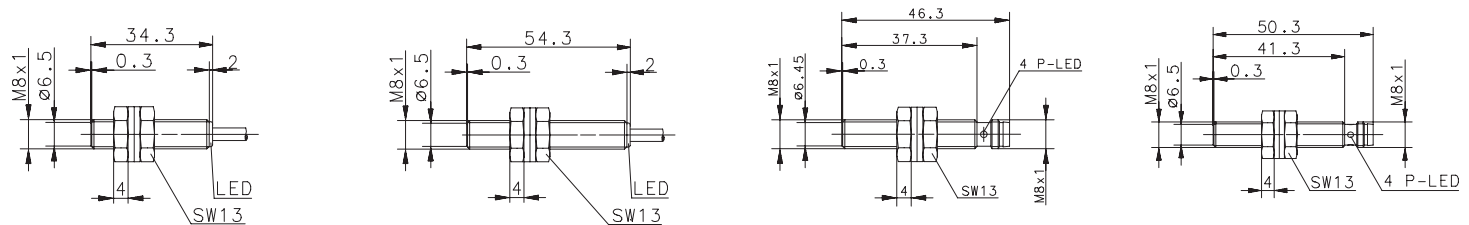

You can find detailed product data sheets at www.bernstein.eu

INDUCTIVE SENSORS Type M8



Type	M8	M8	M8	M8
Enclosure material	Stainless steel 1.4305	Stainless steel 1.4305	Stainless steel 1.4305	Stainless steel 1.4305
Type of installation	flush	flush	flush	flush
Nominal sensing distance	1.5 mm	1.5 mm	1.5 mm	1.5 mm
Type of connection	Cable 2 m	Cable 2 m	Connector M8	Connector M8
Special feature				
PNP	DC	NO contact	6932901001 KIB-M08PS/1,5-KL2	6932942001 KIB-M08PS/1,5-KLSM8
PNP	DC	NC contact	6502701001 KIB-M08PÖ/1,5-KL2	6502742001 KIB-M08PÖ/1,5-KLSM8
NPN	DC	NO contact	6932301001 KIB-M08NS/1,5-KL2	
NPN	DC	NC contact		
Technical data				
Rated operating voltage range	U_B	10–36 VDC	10–36 VDC	10–36 VDC
Rated operating current	I_e	≤ 200 mA	≤ 200 mA	≤ 200 mA
Max. switching voltage	F	1000 Hz	1000 Hz	1000 Hz
Short circuit-protection		cyclic	cyclic	cyclic
Function/operating voltage indicator		LED/-	LED/-	LED/-
Mechanical data				
Ambient temperature (min/max)		-25°C/+70°C	-25°C/+70°C	-25°C/+70°C
Protection class in accordance with IEC 529, EN 60529		IP67	IP67	IP67
Connection		3 x 0.14 mm ²	3 x 0.14 mm ²	M8 x 1

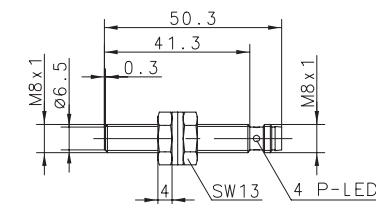
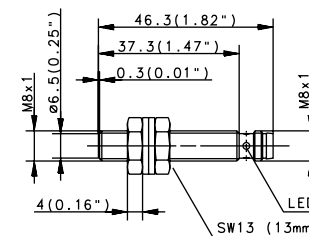
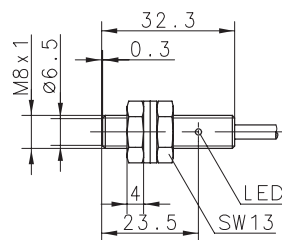
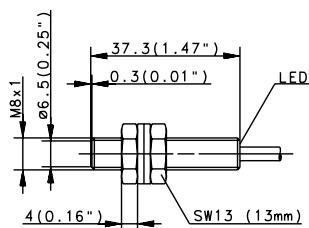

Cable couplings and other accessories can be found from p. 208

Type	M8		
Enclosure material	Stainless steel 1.4305		
Type of installation	flush		
Nominal sensing distance	1.5 mm		
Type of connection	Connector M12		
Special feature			
PNP	DC	NO contact	6502942007 KIB-M08PS/0,1-KS12
PNP	DC	NC contact	
NPN	DC	NO contact	
NPN	DC	NC contact	
Technical data			
Rated operating voltage range	U_B	10–36 VDC	
Rated operating current	I_e	≤ 200 mA	
Max. switching voltage	F	1000 Hz	
Short circuit-protection	cyclic		
Function/operating voltage indicator	–/–		
Mechanical data			
Ambient temperature (min/max)	–25°C/+70°C		
Protection class in accordance with IEC 529, EN 60529	IP67		
Connection	M12 x 1		

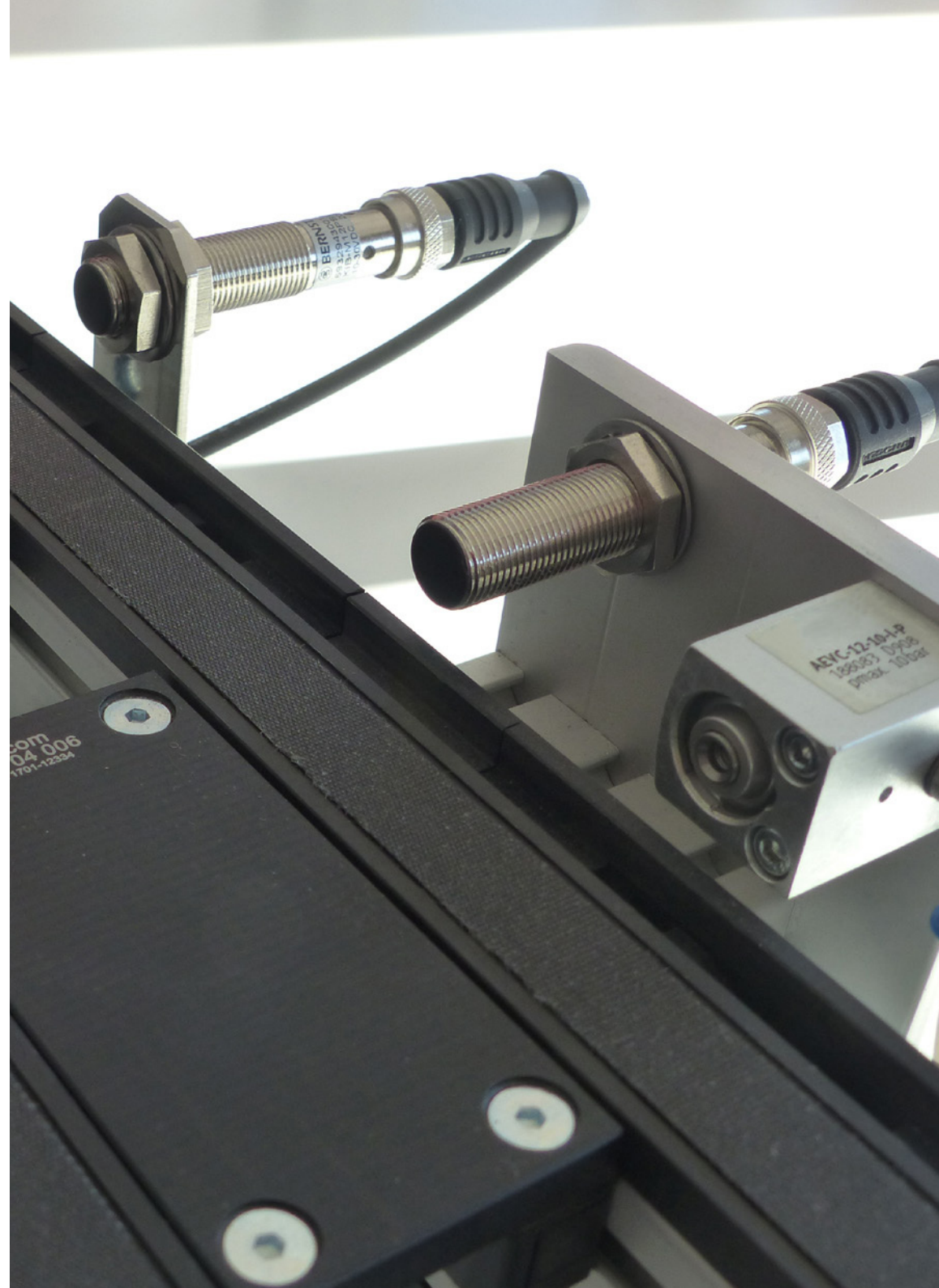
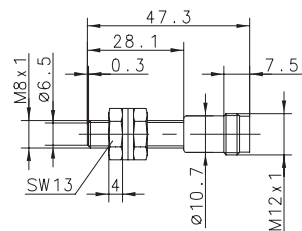

INDUKTIVE SENSOREN Type M8



Type	M8	M8	M8	M8		
Enclosure material	Stainless steel 1.4305	Stainless steel 1.4305	Stainless steel 1.4305	Stainless steel 1.4305		
Type of installation	non-flush	non-flush	non-flush	non-flush		
Nominal sensing distance	2 mm	2 mm	2 mm	2 mm		
Type of connection	Cable 2 m	Cable 2 m	Connector M8	Connector M8		
Special feature	Short type	Standard type	Short type	Standard type		
PNP	DC	NO contact	6532901002 KIN-M08PS/002-KL2VI	6532902002 KIN-M08PS/002-KL2I	6532942002 KIN-M08PS/002-KLSM8VI	6532942004 KIN-M08PS/002-KLSM8I
PNP	DC	NC contact	6532701002 KIN-M08PÖ/002-KL2VI	6532702002 KIN-M08PÖ/002-KL2I	6532742002 KIN-M08PÖ/002-KLSM8VI	6532742004 KIN-M08PÖ/002-KLSM8I
NPN	DC	NO contact	6532301002 KIN-M08NS/002-KL2V	6532302002 KIN-M08NS/002-KL2	6532342002 KIN-M08NS/002-KLSM8V	6532342004 KIN-M08NS/002-KLSM8
NPN	DC	NC contact	6532101002 KIN-M08NÖ/002-KL2V	6532102002 KIN-M08NÖ/002-KL2	6532142002 KIN-M08NÖ/002-KLSM8V	6532142004 KIN-M08NÖ/002-KLSM8
Technical data						
Rated operating voltage range	U_B	10–30 VDC	10–30 VDC	10–30 VDC	10–30 VDC	10–30 VDC
Rated operating current	I_e	≤ 200 mA	≤ 200 mA	≤ 200 mA	≤ 200 mA	≤ 200 mA
Max. switching voltage	F	750 Hz	750 Hz	750 Hz	750 Hz	750 Hz
Short circuit-protection		cyclic	cyclic	cyclic	cyclic	cyclic
Function/operating voltage indicator		LED/–	LED/–	LED/–	LED/–	LED/–
Mechanical data						
Ambient temperature (min/max)		–25°C/+70°C	–25°C/+70°C	–25°C/+70°C	–25°C/+70°C	–25°C/+70°C
Protection class in accordance with IEC 529, EN 60529		IP67	IP67	IP67	IP67	IP67
Connection		3 x 0.14 mm ²	3 x 0.14 mm ²	M8 x 1	M8 x 1	M8 x 1
Approvals						

= IO-Link

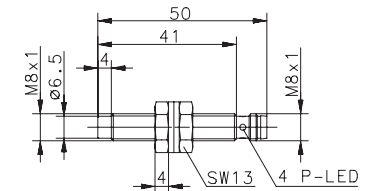
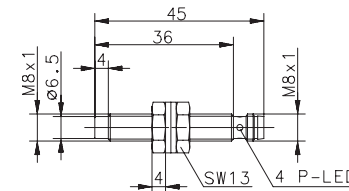
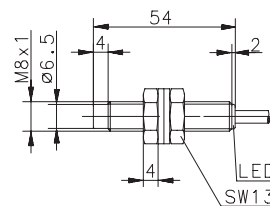
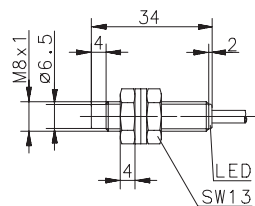

Cable couplings and other accessories can be found from p. 208

Type	M8		
Enclosure material	Stainless steel 1.4305		
Type of installation	non-flush		
Nominal sensing distance	2 mm		
Type of connection	Connector M12		
Special feature			
PNP	DC	NO contact	6502942008 KIN-M08PS/002-KS12
PNP	DC	NC contact	
NPN	DC	NO contact	
NPN	DC	NC contact	
Technical data			
Rated operating voltage range	U_B	10–36 VDC	
Rated operating current	I_e	≤ 200 mA	
Max. switching voltage	F	750 Hz	
Short circuit-protection	cyclic		
Function/operating voltage indicator	–/–		
Mechanical data			
Ambient temperature (min/max)	–25°C/+70°C		
Protection class in accordance with IEC 529, EN 60529	IP67		
Connection	M12 x 1		
Approvals			

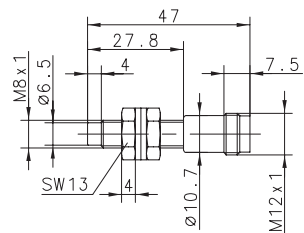

INDUCTIVE SENSORS Type M12



Type	M12	M12	M12	M12		
Enclosure material	CuZn39Pb3	CuZn39Pb3	CuZn39Pb3	CuZn39Pb3		
Type of installation	flush	flush	flush	flush		
Nominal sensing distance	2 mm	2 mm	2 mm	2 mm		
Type of connection	Cable 2 m	Cable 2 m	Connector M12	Connector M12		
Special feature	Short type	Standard type	Short type	Standard type		
PNP	DC	NO contact	6532903001 KIB-M12PS/002-KL2VI	6532903002 KIB-M12PS/002-KL2I	6532943001 KIB-M12PS/002-KLS12VI	6532943002 KIB-M12PS/002-KLS12I
PNP	DC	NC contact	6532703001 KIB-M12PÖ/002-KL2VI	6532703002 KIB-M12PÖ/002-KL2I	6532743001 KIB-M12PÖ/002-KLS12VI	6532743002 KIB-M12PÖ/002-KLS12I
NPN	DC	NO contact	6532303001 KIB-M12NS/002-KL2V	6532303002 KIB-M12NS/002-KL2	6532343001 KIB-M12NS/002-KLS12V	6532343002 KIB-M12NS/002-KLS12
NPN	DC	NC contact	6532103001 KIB-M12NÖ/002-KL2V	6532103002 KIB-M12NÖ/002-KL2	6532143001 KIB-M12NÖ/002-KLS12V	6532143002 KIB-M12NÖ/002-KLS12
Technical data						
Rated operating voltage range	U_B	10–30 VDC	10–30 VDC	10–30 VDC	10–30 VDC	10–30 VDC
Rated operating current	I_e	≤ 200 mA	≤ 200 mA	≤ 200 mA	≤ 200 mA	≤ 200 mA
Max. switching voltage	F	800 Hz	800 Hz	800 Hz	800 Hz	800 Hz
Short circuit-protection		cyclic	cyclic	cyclic	cyclic	cyclic
Function/operating voltage indicator		LED/–	LED/–	LED/–	LED/–	LED/–
Mechanical data						
Ambient temperature (min/max)		–25°C/+70°C	–25°C/+70°C	–25°C/+70°C	–25°C/+70°C	–25°C/+70°C
Protection class in accordance with IEC 529, EN 60529		IP67	IP67	IP67	IP67	IP67
Connection		3 x 0.14 mm ²	3 x 0.14 mm ²	M12 x 1	M12 x 1	M12 x 1
Approvals						

= IO-Link

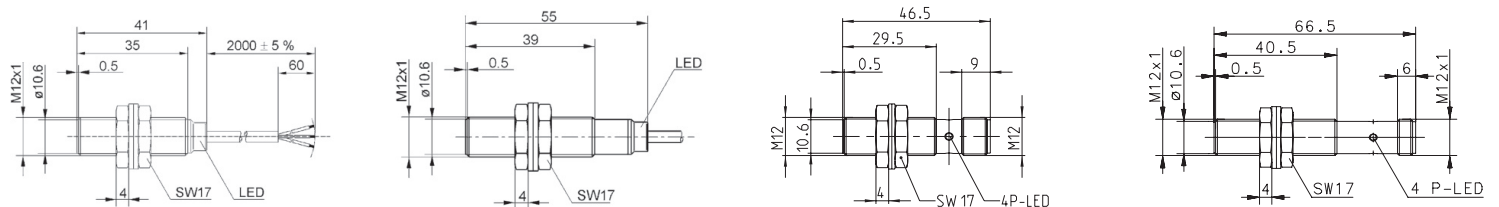

Cable couplings and other accessories can be found from p. 208



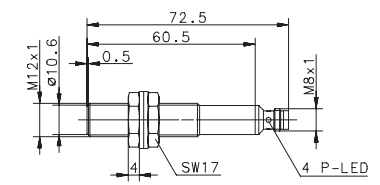
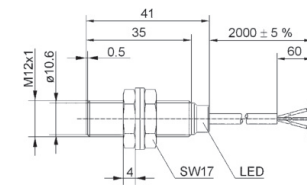
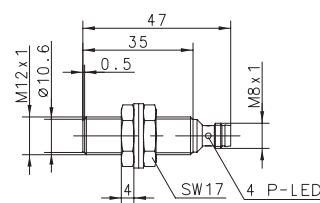
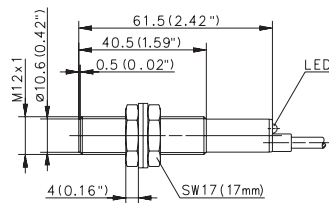

Type	M12	M12	M12	M12
Enclosure material	CuZn39Pb3	CuZn39Pb3	CuZn39Pb3	CuZn39Pb3
Type of installation	flush	flush	flush	flush
Nominal sensing distance	2 mm	2 mm	4 mm	4 mm
Type of connection	Cable 2 m	Connector M8	Cable 2 m	Connector M8
Special feature	4000 Hz	Short type	Short type	
PNP	DC	NO contact	6502903012 KIB-M12PS/002-KL2F	6502943008 KIB-M12PS/002-KLSM8V
PNP	DC	NC contact		6532903003 KIB-M12PS/004-KL2EVI
NPN	DC	NO contact		6602343366 KIB-M12NS/004-KLSM8E
NPN	DC	NC contact		
Technical data				
Rated operating voltage range	U_B	10–60 VDC	10–30 VDC	10–30 VDC
Rated operating current	I_e	≤ 200 mA	≤ 200 mA	200 mA
Max. switching voltage	F	4000 Hz	800 Hz	800 Hz
Short circuit-protection		cyclic	cyclic	cyclic
Function/operating voltage indicator		LED/–	LED/–	LED/–
Mechanical data				
Ambient temperature (min/max)		–25°C/+70°C	–25°C/+70°C	–25°C/+70°C
Protection class in accordance with IEC 529, EN 60529		IP67	IP67	IP67
Connection		3 x 0.14 mm ²	M8 x 1	3 x 0.14 mm ²
Approvals				

= IO-Link



INDUCTIVE SENSORS Type M12



Type	M12	M12
Enclosure material	CuZn39Pb3	CuZn39Pb3
Type of installation	flush	flush
Nominal sensing distance	4 mm	4 mm
Type of connection	Connector M12	Connector M12
Special feature	Sensing distance	Sensing distance
PNP	DC	NO contact
		6502943015 KIB-M12PS/004-KLS12E
		 6532943004 KIB-M12PS/004-KLS12EVI
PNP	DC	NC contact
NPN	DC	NO contact
NPN	DC	NC contact
Technical data		
Rated operating voltage range	U_B	10–36 VDC
Rated operating current	I_e	≤ 200 mA
Max. switching voltage	F	800 Hz
Short circuit-protection		cyclic
Function/operating voltage indicator		LED/–
Mechanical data		
Ambient temperature (min/max)		–25°C/+70°C
Protection class in accordance with IEC 529, EN 60529		IP67
Connection		M12 x 1
Approvals		

 =  IO-Link

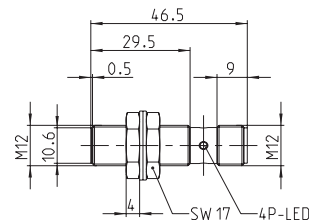
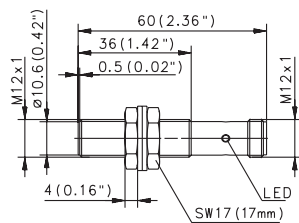

Cable couplings and other accessories can be found from p. 208



Type	M12	M12	M12	M12		
Enclosure material	CuZn39Pb3	CuZn39Pb3	CuZn39Pb3	CuZn39Pb3		
Type of installation	non-flush	non-flush	non-flush	non-flush		
Nominal sensing distance	4 mm	4 mm	4 mm	4 mm		
Type of connection	Cable 2 m	Cable 2 m	Connector M12	Connector M12		
Special feature	Short type	Standard type	Short type	Standard type		
PNP	DC	NO contact	6532904001 KIN-M12PS/004-KL2VI	6532904002 KIN-M12PS/004-KL2I	6532944001 KIN-M12PS/004-KLS12VI	6532944002 KIN-M12PS/004-KLS12I
PNP	DC	NC contact	6532704001 KIN-M12PÖ/004-KL2VI	6532704002 KIN-M12PÖ/004-KL2I	6532744001 KIN-M12PÖ/004-KLS12VI	6532744002 KIN-M12PÖ/004-KLS12I
NPN	DC	NO contact	6532304001 KIN-M12NS/004-KL2V	6532304002 KIN-M12NS/004-KL2	6532344001 KIN-M12NS/004-KLS12V	6532344002 KIN-M12NS/004-KLS12
NPN	DC	NC contact	6532104001 KIN-M12NÖ/004-KL2V	6532104002 KIN-M12NÖ/004-KL2	6532144001 KIN-M12NÖ/004-KLS12V	6532144002 KIN-M12NÖ/004-KLS12
Technical data						
Rated operating voltage range	U_B	10–30 VDC	10–30 VDC	10–30 VDC	10–30 VDC	10–30 VDC
Rated operating current	I_e	≤ 200 mA	≤ 200 mA	≤ 200 mA	≤ 200 mA	≤ 200 mA
Max. switching voltage	F	1000 Hz	1000 Hz	1000 Hz	1000 Hz	1000 Hz
Short circuit-protection		cyclic	cyclic	cyclic	cyclic	cyclic
Function/operating voltage indicator		LED/–	LED/–	LED/–	LED/–	LED/–
Mechanical data						
Ambient temperature (min/max)		–25°C/+70°C	–25°C/+70°C	–25°C/+70°C	–25°C/+70°C	–25°C/+70°C
Protection class in accordance with IEC 529, EN 60529		IP67	IP67	IP67	IP67	IP67
Connection		3 x 0.14 mm ²	3 x 0.14 mm ²	M12 x 1	M12 x 1	M12 x 1
Approvals						

= IO-Link

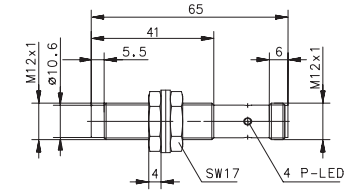
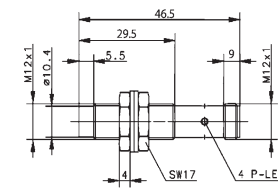
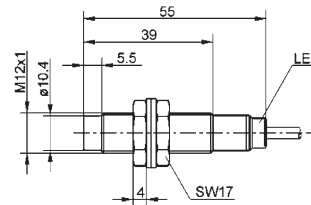
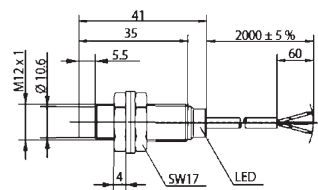

INDUCTIVE SENSORS Type M12



Type	M12	M12	M12	M12
Enclosure material	CuZn39Pb3	PA, red	CuZn39Pb3	CuZn39Pb3
Type of installation	non-flush	non-flush	non-flush	non-flush
Nominal sensing distance	4 mm	4 mm	8 mm	8 mm
Type of connection	Connector M8	Cable 2 m	Cable 2 m	Connector M12
Special feature	Short type		Sensing distance	Sensing distance
PNP	DC	NO contact	6502919001 KIN-T12PS/004-KL2	6502904021 KIN-M12PS/008-KL2E
PNP	DC	NC contact	6502744006 KIN-M12PÖ/004-KLSM8V	6502944013 KIN-M12PS/008-KLS12E
NPN	DC	NO contact		
NPN	DC	NC contact		
Technical data				
Rated operating voltage range	U_B	10–36 VDC	10–30 VDC	10–36 VDC
Rated operating current	I_e	≤ 200 mA	≤ 200 mA	≤ 200 mA
Max. switching voltage	F	1000 Hz	1000 Hz	400 Hz
Short circuit-protection		cyclic	cyclic	cyclic
Function/operating voltage indicator		LED/–	LED/–	LED/–
Mechanical data				
Ambient temperature (min/max)		–25°C/+70°C	–25°C/+70°C	–25°C/+70°C
Protection class in accordance with IEC 529, EN 60529		IP67	IP67	IP67
Connection		M8 x 1	3 x 0.14 mm ²	M12 x 1

Approvals

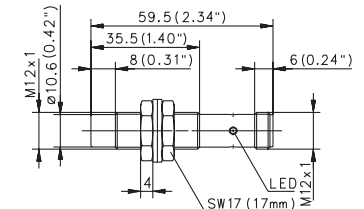
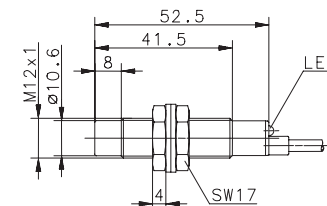
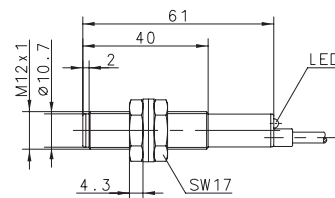
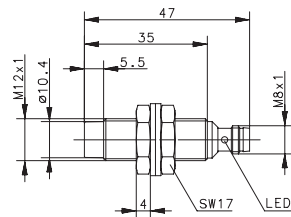

Cable couplings and other accessories can be found from p. 208

INDUCTIVE SENSORS Type M18



Type	M18	M18	M18	M18		
Enclosure material	CuZn39Pb3	CuZn39Pb3	CuZn39Pb3	CuZn39Pb3		
Type of installation	flush	flush	flush	flush		
Nominal sensing distance	5 mm	5 mm	5 mm	5 mm		
Type of connection	Cable 2 m	Cable 2 m	Connector M12	Connector M12		
Special feature	Short type	Standard type	Short type	Standard type		
PNP	DC	NO contact	6532905001 KIB-M18PS/005-KL2VI	6532905002 KIB-M18PS/005-KL2I	6532905003 KIB-M18PS/005-KLS12VI	6532905004 KIB-M18PS/005-KLS12I
PNP	DC	NC contact	6532705001 KIB-M18PÖ/005-KL2VI	6532705002 KIB-M18PÖ/005-KL2I	6532705003 KIB-M18PÖ/005-KLS12VI	6532705004 KIB-M18PÖ/005-KLS12I
NPN	DC	NO contact	6532305001 KIB-M18NS/005-KL2V	6532305002 KIB-M18NS/005-KL2	6532305003 KIB-M18NS/005-KLS12V	6532305004 KIB-M18NS/005-KLS12
NPN	DC	NC contact	6532105001 KIB-M18NÖ/005-KL2V	6532105002 KIB-M18NÖ/005-KL2	6532105003 KIB-M18NÖ/005-KLS12V	6532105004 KIB-M18NÖ/005-KLS12
Technical data						
Rated operating voltage range	U_B	10–30 VDC	10–30 VDC	10–30 VDC	10–30 VDC	10–30 VDC
Rated operating current	I_e	≤ 200 mA	≤ 200 mA	≤ 200 mA	≤ 200 mA	≤ 200 mA
Max. switching voltage	F	500 Hz	500 Hz	500 Hz	500 Hz	500 Hz
Short circuit-protection		cyclic	cyclic	cyclic	cyclic	cyclic
Function/operating voltage indicator		LED/–	LED/–	LED/–	LED/–	LED/–
Mechanical data						
Ambient temperature (min/max)		–25°C/+70°C	–25°C/+70°C	–25°C/+70°C	–25°C/+70°C	–25°C/+70°C
Protection class in accordance with IEC 529, EN 60529		IP67	IP67	IP67	IP67	IP67
Connection		3 x 0.34 mm ²	3 x 0.34 mm ²	M12 x 1	M12 x 1	M12 x 1
Approvals						

= IO-Link

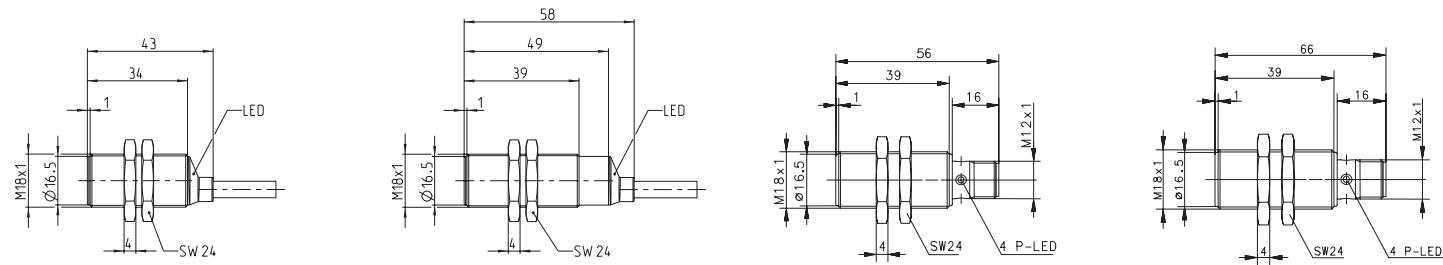

You can find detailed product data sheets at www.bernstein.eu

INDUCTIVE SENSORS Type M18



Type	M18	M18	M18	M18
Enclosure material	CuZn39Pb3	CuZn39Pb3	CuZn39Pb3	PA, red
Type of installation	flush	flush	flush	flush
Nominal sensing distance	5 mm	5 mm	5 mm	5 mm
Type of connection	DIN Connector	DIN Connector	Cable 2 m	Cable 2 m
Special feature			Temperature	
PNP	DC	NO contact	6602905662 KIB-M18PS/005-KLSD	6502940001 KIB-M18PS/005-KLSDV
PNP	DC	NC contact	6502705001 KIB-M18PÖ/005-KLSD	6502905023 KIB-M18PS/005-KL2PUT
NPN	DC	NO contact		6502920990 KIB-T18PS/005-KL2
NPN	DC	NC contact		
Technical data				
Rated operating voltage range	U_B	10–60 VDC	10–60 VDC	10–30 VDC
Rated operating current	I_e	≤ 200 mA	≤ 200 mA	≤ 200 mA
Max. switching voltage	F	500 Hz	500 Hz	500 Hz
Short circuit-protection		–	cyclic	cyclic
Function/operating voltage indicator		LED/–	LED/–	LED/–
Mechanical data				
Ambient temperature (min/max)		–25°C/+70°C	–25°C/+70°C	–40°C/+100°
Protection class in accordance with IEC 529, EN 60529		IP65	IP65	IP67
Connection		Plug connector DIN EN 175301-803	Plug connector DIN EN 175301-803	3 x 0.5 mm ²

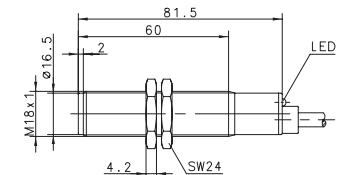
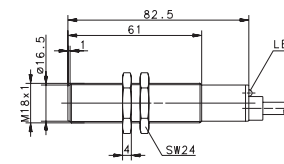
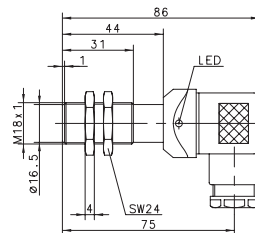
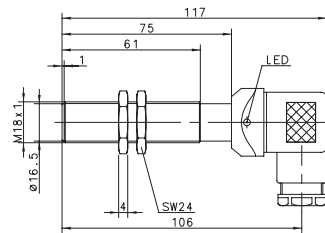

Cable couplings and other accessories can be found from p. 208



Type	M18	M18	M18	M18
Enclosure material	CuZn39Pb3	CuZn39Pb3	CuZn39Pb3	CuZn39Pb3
Type of installation	flush	flush	flush	non-flush
Nominal sensing distance	8 mm	8 mm	8 mm	8 mm
Type of connection	Cable 2 m	Cable 2 m	Connector	DIN Connector
Special feature	Sensing distance	Sensing distance	Sensing distance	
PNP	DC	NO contact	6502905010 KIB-M18PS/008-KL2VE	6502905022 KIB-M18PS/008-KL2E
PNP	DC	NC contact		6502940005 KIB-M18PS/008-KLS12E
NPN	DC	NO contact		6502941001 KIN-M18PS/008-KLSD
NPN	DC	NC contact		6502741001 KIN-M18PÖ/008-KLSD
Technical data				
Rated operating voltage range	U_B	10–36 VDC	10–36 VDC	10–36 VDC
Rated operating current	I_e	≤ 200 mA	≤ 200 mA	≤ 200 mA
Max. switching voltage	F	500 Hz	500 Hz	500 Hz
Short circuit-protection		cyclic	cyclic	cyclic
Function/operating voltage indicator		LED/-	LED/-	-/-
Mechanical data				
Ambient temperature (min/max)		-25°C/+70°C	-25°C/+70°C	-25°C/+70°C
Protection class in accordance with IEC 529, EN 60529		IP67	IP67	IP65
Connection		3 x 0.5 mm ²	3 x 0.5 mm ²	M12 x 1 Plug connector DIN EN 175301-803

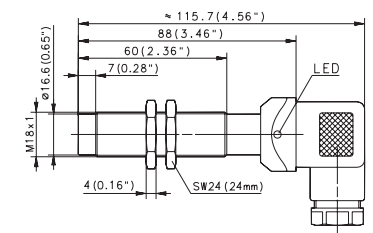
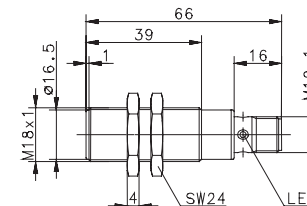
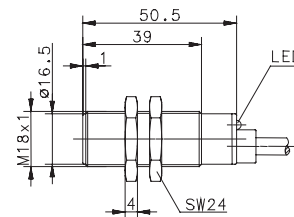
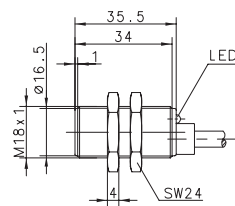

INDUCTIVE SENSORS Type M18



Type	M18	M18	M18	M18		
Enclosure material	CuZn39Pb3	CuZn39Pb3	CuZn39Pb3	CuZn39Pb3		
Type of installation	non-flush	non-flush	non-flush	non-flush		
Nominal sensing distance	8 mm	8 mm	8 mm	8 mm		
Type of connection	Cable 2 m	Cable 2 m	Connector M12	Connector M12		
Special feature	Short type	Standard type	Short type	Standard type		
PNP	DC	NO contact	6532906001 KIN-M18PS/008-KL2VI	6532906002 KIN-M18PS/008-KL2I	6532906003 KIN-M18PS/008-KLS12VI	6532906004 KIN-M18PS/008-KLS12I
PNP	DC	NC contact	6532706001 KIN-M18PÖ/008-KL2VI	6532706002 KIN-M18PÖ/008-KL2I	6532706003 KIN-M18PÖ/008-KLS12VI	6532706004 KIN-M18PÖ/008-KLS12I
NPN	DC	NO contact	6532306001 KIN-M18NS/008-KL2V	6532306002 KIN-M18NS/008-KL2	6532306003 KIN-M18NS/008-KLS12V	6532306004 KIN-M18NS/008-KLS12
NPN	DC	NC contact	6532106001 KIN-M18NÖ/008-KL2V	6532106002 KIN-M18NÖ/008-KL2	6532106003 KIN-M18NÖ/008-KLS12V	6532106004 KIN-M18NÖ/008-KLS12
Technical data						
Rated operating voltage range	U_B	10–30 VDC	10–30 VDC	10–30 VDC	10–30 VDC	10–30 VDC
Rated operating current	I_e	≤ 200 mA	≤ 200 mA	≤ 200 mA	≤ 200 mA	≤ 200 mA
Max. switching voltage	F	200 Hz	200 Hz	200 Hz	200 Hz	200 Hz
Short circuit-protection		cyclic	cyclic	cyclic	cyclic	cyclic
Function/operating voltage indicator		LED/–	LED/–	LED/–	LED/–	LED/–
Mechanical data						
Ambient temperature (min/max)		–25°C/+70°C	–25°C/+70°C	–25°C/+70°C	–25°C/+70°C	–25°C/+70°C
Protection class in accordance with IEC 529, EN 60529		IP67	IP67	IP67	IP67	IP67
Connection		3 x 0.34 mm ²	3 x 0.34 mm ²	M12 x 1	M12 x 1	M12 x 1
Approvals						

= IO-Link

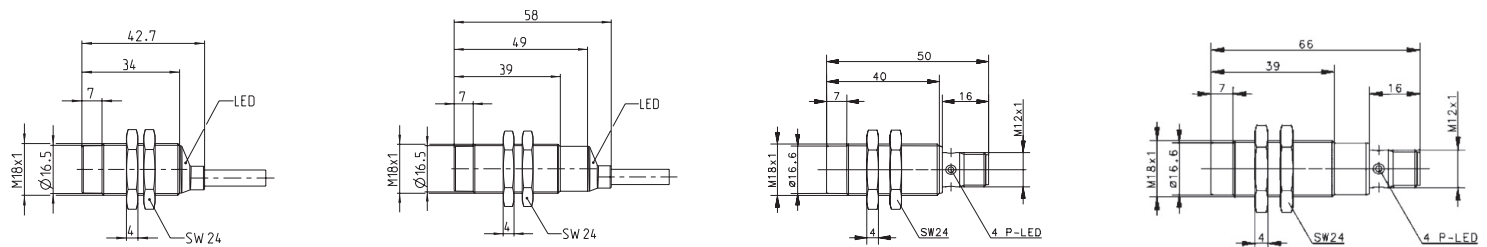

Cable couplings and other accessories can be found from p. 208



Type	M18	M18	M18	M18
Enclosure material	PA, red	CuZn39Pb3	CuZn39Pb3	CuZn39Pb3
Type of installation	non-flush	non-flush	non-flush	non-flush
Nominal sensing distance	8 mm	8 mm	16 mm	16 mm
Type of connection	Cable 2 m	Connector M12	Cable 2 m	Connector M12
Special feature		Sensing distance / Short type	Sensing distance	Sensing distance
PNP	DC	NO contact	6502921975 KIN-T18PS/008-KL2	6502906009 KIN-M18PS/008-KS12V
PNP	DC	NC contact		6502906018 KIN-M18PS/016-KL2E
NPN	DC	NO contact		6502941004 KIN-M18PS/016-KLS12E
NPN	DC	NC contact		
Technical data				
Rated operating voltage range	U_B	10–60 VDC	10–60 VDC	10–36 VDC
Rated operating current	I_e	≤ 200 mA	≤ 200 mA	≤ 200 mA
Max. switching voltage	F	200 Hz	200 Hz	200 Hz
Short circuit-protection		cyclic	cyclic	cyclic
Function/operating voltage indicator		LED/–	–/–	LED/–
Mechanical data				
Ambient temperature (min/max)		–25°C/+70°C	–25°C/+70°C	–25°C/+70°C
Protection class in accordance with IEC 529, EN 60529		IP67	IP67	IP67
Connection		3 x 0.5 mm ²	M12 x 1	3 x 0.5 mm ²

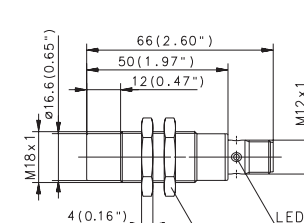
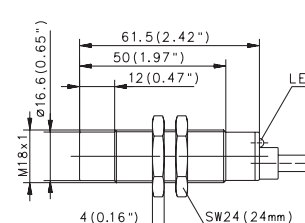
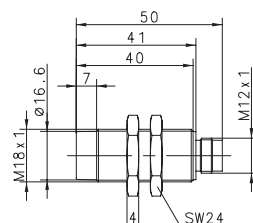
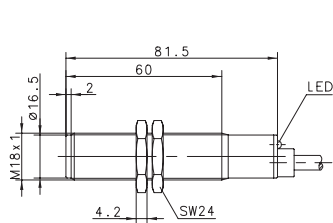

INDUCTIVE SENSORS Type M30



Type	M30	M30	M30	M30		
Enclosure material	CuZn39Pb3	CuZn39Pb3	CuZn39Pb3	CuZn39Pb3		
Type of installation	flush	flush	flush	flush		
Nominal sensing distance	10 mm	10 mm	10 mm	10 mm		
Type of connection	Cable 2 m	Cable 2 m	Connector M12	Connector M12		
Special feature	Short type	Standard type	Short type	Standard type		
PNP	DC	NO contact	6532907001 KIB-M30PS/010-KL2VI	6532907002 KIB-M30PS/010-KL2I	6532907003 KIB-M30PS/010-KLS12VI	6532907004 KIB-M30PS/010-KLS12I
PNP	DC	NC contact	6532707001 KIB-M30PÖ/010-KL2VI	6532707002 KIB-M30PÖ/010-KL2I	6532707003 KIB-M30PÖ/010-KLS12VI	6532707004 KIB-M30PÖ/010-KLS12I
NPN	DC	NO contact	6532307001 KIB-M30NS/010-KL2V	6532307002 KIB-M30NS/010-KL2	6532307003 KIB-M30NS/015-KLS12V	6532307004 KIB-M30NS/010-KLS12
NPN	DC	NC contact	6532107001 KIB-M30NÖ/010-KL2V	6532107002 KIB-M30NÖ/010-KL2	6532107003 KIB-M30NÖ/010-KLS12V	6532107004 KIB-M30NÖ/010-KLS12
Technical data						
Rated operating voltage range	U_B	10–30 VDC	10–30 VDC	10–30 VDC	10–30 VDC	10–30 VDC
Rated operating current	I_e	≤ 200 mA	≤ 200 mA	≤ 200 mA	≤ 200 mA	≤ 200 mA
Max. switching voltage	F	300 Hz	300 Hz	300 Hz	300 Hz	300 Hz
Short circuit-protection		cyclic	cyclic	cyclic	cyclic	cyclic
Function/operating voltage indicator		LED/–	LED/–	LED/–	LED/–	LED/–
Mechanical data						
Ambient temperature (min/max)		–25°C/+70°C	–25°C/+70°C	–25°C/+70°C	–25°C/+70°C	–25°C/+70°C
Protection class in accordance with IEC 529, EN 60529		IP67	IP67	IP67	IP67	IP67
Connection		3 x 0.34 mm ²	3 x 0.34 mm ²	M12 x 1	M12 x 1	M12 x 1
Approvals						

= IO-Link

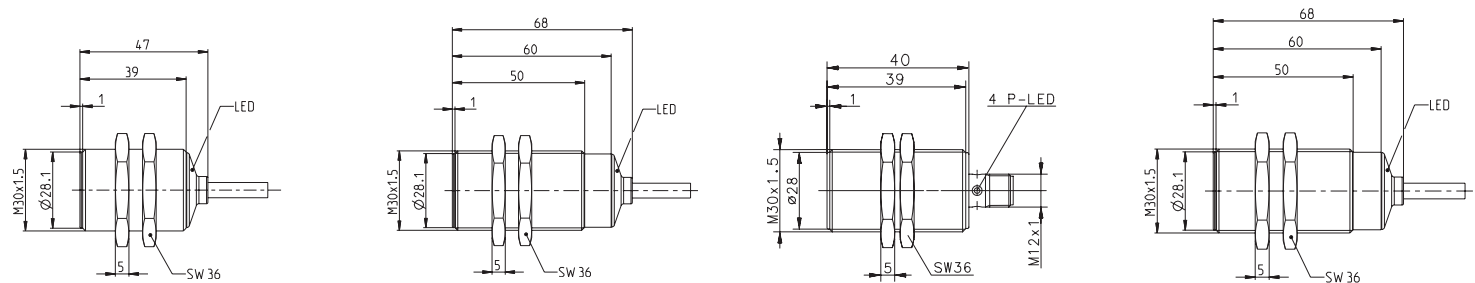

Cable couplings and other accessories can be found from p. 208



Type	M30	M30	M30	M30
Enclosure material	PA, red	CuZn39Pb3	CuZn39Pb3	PA, red
Type of installation	flush	flush	flush	flush
Nominal sensing distance	10 mm	10 mm	10 mm	10 mm
Type of connection	Cable 2 m	Connector M12	DIN Connector	DIN Connector
Special feature		Temperature		
PNP	DC	NO contact	6502939006 KIB-M30PS/010-KLS12T	6502939001 KIB-M30PS/010-KLSD
PNP	DC	NC contact	6502722708 KIB-T30PÖ/010-KL2	6502739001 KIB-M30PÖ/010-KLSD
NPN	DC	NO contact		
NPN	DC	NC contact		
PNP/NPN	DC	NO/NC prog.		6502822862 KIB-T30PP/010-KLSD
Technical data				
Rated operating voltage range	U_B	10–60 VDC	10–30 VDC	10–60 VDC
Rated operating current	I_e	≤ 200 mA	≤ 200 mA	≤ 200 mA
Max. switching voltage	F	300 Hz	300 Hz	300 Hz
Short circuit-protection		cyclic	cyclic	cyclic
Function/operating voltage indicator		LED/–	LED/–	LED/–
Mechanical data				
Ambient temperature (min/max)		–25°C/+70°C	–40°C/+100°	–25°C/+70°C
Protection class in accordance with IEC 529, EN 60529		IP67	IP67	IP65
Connection		3 x 0.5 mm ²	M12 x 1	Plug connector DIN EN 175301-803

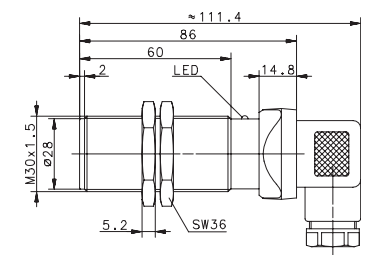
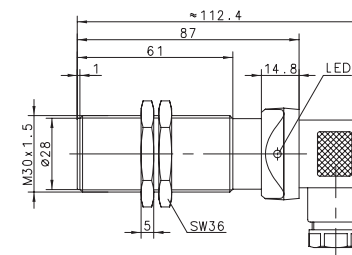
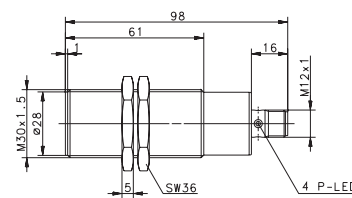
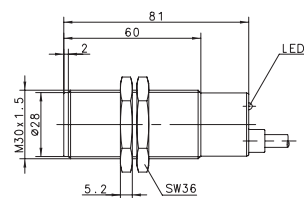

INDUCTIVE SENSORS Type M30



Type	M30	M30	M30	M30
Enclosure material	CuZn39Pb3	CuZn39Pb3	CuZn39Pb3	CuZn39Pb3
Type of installation	non-flush	non-flush	non-flush	non-flush
Nominal sensing distance	15 mm	15 mm	15 mm	15 mm
Type of connection	Cable 2 m	Cable 2 m	Connector M12	Connector M12
Special feature	Short type	Standard type	Short type	Standard type
PNP DC NO contact	6532908001 KIN-M30PS/015-KL2VI	6532908002 KIN-M30PS/015-KL2I	6532908003 KIN-M30PS/015-KLS12VI	6532908004 KIN-M30PS/015-KLS12I
PNP DC NC contact	6532708001 KIN-M30PÖ/015-KL2VI	6532708002 KIN-M30PÖ/015-KL2I	6532708003 KIN-M30PÖ/015-KLS12VI	6532708004 KIN-M30PÖ/015-KLS12I
NPN DC NO contact	6532308001 KIN-M30NS/015-KL2V	6532308002 KIN-M30NS/015-KL2	6532308003 KIN-M30NS/015-KLS12V	6532308004 KIN-M30NS/015-KLS12
NPN DC NC contact	6532108001 KIN-M30NÖ/015-KL2V	6532108002 KIN-M30NÖ/015-KL2	6532108003 KIN-M30NÖ/015-KLS12V	6532108004 KIN-M30NÖ/015-KLS12
Technical data				
Rated operating voltage range	U_B 10–30 VDC	10–30 VDC	10–30 VDC	10–30 VDC
Rated operating current	I_e ≤ 200 mA	≤ 200 mA	≤ 200 mA	≤ 200 mA
Max. switching voltage	F 100 Hz	100 Hz	100 Hz	100 Hz
Short circuit-protection	cyclic	cyclic	cyclic	cyclic
Function/operating voltage indicator	LED/–	LED/–	LED/–	LED/–
Mechanical data				
Ambient temperature (min/max)	–25°C/+70°C	–25°C/+70°C	–25°C/+70°C	–25°C/+70°C
Protection class in accordance with IEC 529, EN 60529	IP67	IP67	IP67	IP67
Connection	3 x 0.34 mm ²	3 x 0.34 mm ²	M12 x 1	M12 x 1
Approvals				

= IO-Link

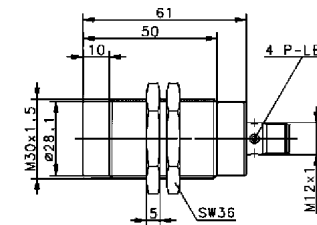
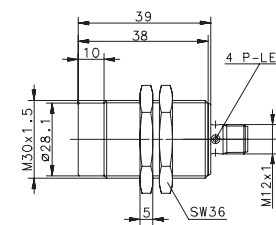
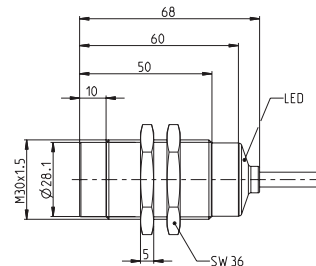
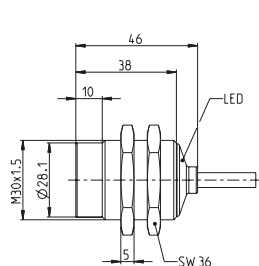

Cable couplings and other accessories can be found from p. 208



Type	M30	M30	M30
Enclosure material	PA, red	PA, red	CuZn39Pb3
Type of installation	non-flush	non-flush	non-flush
Nominal sensing distance	15 mm	15 mm	15 mm
Type of connection	Cable 2 m	Connector	DIN Connector
Special feature			
PNP	DC	NO contact	6502923981 KIN-T30PS/015-KL2
PNP	DC	NC contact	6502923002 KIN-T30PS/015-KS12
NPN	DC	NO contact	6502935001 KIN-M30PS/015-KLSD
NPN	DC	NC contact	
Technical data			
Rated operating voltage range	U_B	10–60 VDC	10–60 VDC
Rated operating current	I_e	≤ 200 mA	≤ 200 mA
Max. switching voltage	F	100 Hz	100 Hz
Short circuit-protection		cyclic	cyclic
Function/operating voltage indicator		LED/–	LED/–
Mechanical data			
Ambient temperature (min/max)		–25°C/+70°C	–25°C/+70°C
Protection class in accordance with IEC 529, EN 60529		IP67	IP65
Connection		3 x 0.5 mm ²	Plug connector DIN EN 175301-803

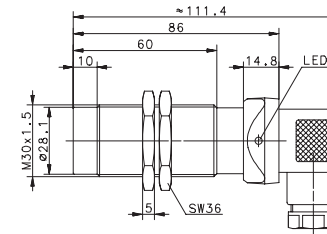
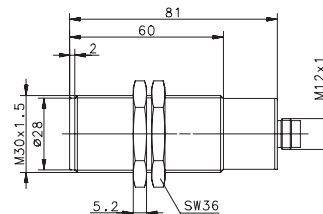
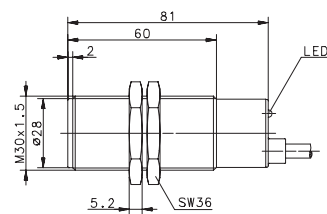

INDUCTIVE SENSORS Type Ø 34 mm, 5 x 5 x 25 mm, 8 x 8 x 40 mm



Type	Ø 34 mm	Ø 34 mm	5 x 5 x 25 mm	8 x 8 x 40 mm
Enclosure material	PBT, red	PBT, red	CuZn39Pb3	CuZn39Pb3
Type of installation	non-flush	non-flush	flush	flush
Nominal sensing distance	20 mm	20 mm	1.5 mm	1.5 mm
Type of connection	Cable 2 m	Connector	Cable	Cable 2 m
Special feature				
PNP	DC	NO contact	6502915002 KIN-R34PS/020-KL2	6502915004 KIN-R34PS/020-KS12
PNP	DC	NC contact		6502999026 KIB-Q05PS/001-K2PU
PNP	DC	antivalent NO/NC		6502799010 KIB-Q05PÖ/001-K2PU
NPN	DC	NO contact		6502980004 KIB-Q08PS/1,5-K2
				6502780001 KIB-Q08PÖ/1,5-K2
Technical data				
Rated operating voltage range	U_B	10–60 VDC	10–60 VDC	10–30 VDC
Rated operating current	I_e	≤ 200 mA	≤ 200 mA	200 mA
Max. switching voltage	F	100 Hz	100 Hz	1000 Hz
Short circuit-protection		cyclic	cyclic	cyclic
Function/operating voltage indicator		LED/–	LED/–	–/–
Mechanical data				
Ambient temperature (min/max)		–25°C/+70°C	–25°C/+70°C	–25°C/+70°C
Protection class in accordance with IEC 529, EN 60529		IP67	IP67	IP67
Connection		3 x 0.5 mm ²	M12 x 1	3 x 0.05 mm ²

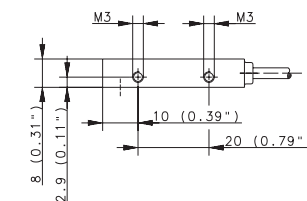
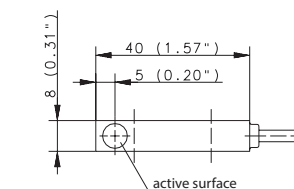
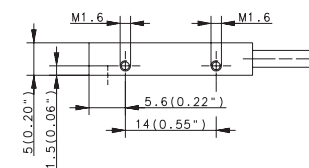
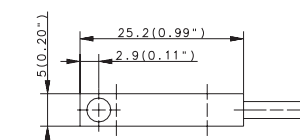
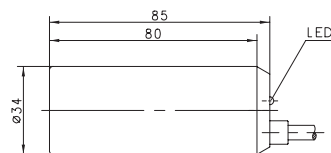

Cable couplings and other accessories can be found from p. 208

INDUCTIVE SENSORS Type 8x8x40 mm, 8x8x56 mm, 12x12x55 mm, 28x16x11 mm



Type	8 x 8 x 40 mm	8 x 8 x 56 mm	12 x 12 x 55 mm	28 x 16 x 11 mm
Enclosure material	CuZn39Pb3	CuZn39Pb3	CuZn39Pb3	PA, black
Type of installation	flush	flush	flush	flush
Nominal sensing distance	1.5 mm	1.5 mm	4 mm	2 mm
Type of connection	Cable 2 m	Connector M8	Cable 2 m	Cable 2 m
Special feature	Temperature			
PNP	DC	NO contact	6502980087 KIB-Q08PS/1,5-K2T	6502980002 KIB-Q08PS/1,5-KLSM8
PNP	DC	NC contact	6502780002 KIB-Q08PÖ/1,5-KLSM8	6502999028 KIB-Q12PS/004-KL2E
NPN	DC	NO contact		6502973001 KIB-E28PS/002-KL2
NPN	DC	NC contact		
Technical data				
Rated operating voltage range	U_B	10–36 VDC	10–36 VDC	10–60 VDC
Rated operating current	I_e	≤ 200 mA	≤ 200 mA	≤ 200 mA
Max. switching voltage	F	1000 Hz	1000 Hz	800 Hz
Short circuit-protection		cyclic	cyclic	cyclic
Function/operating voltage indicator		–/–	LED/–	LED/–
Mechanical data				
Ambient temperature (min/max)		0°C/+100°C	–25°C/+70°C	–25°C/+70°C
Protection class in accordance with IEC 529, EN 60529		IP67	IP67	IP67
Connection		3 x 0.14 mm ²	M8 x 1	3 x 0.14 mm ²

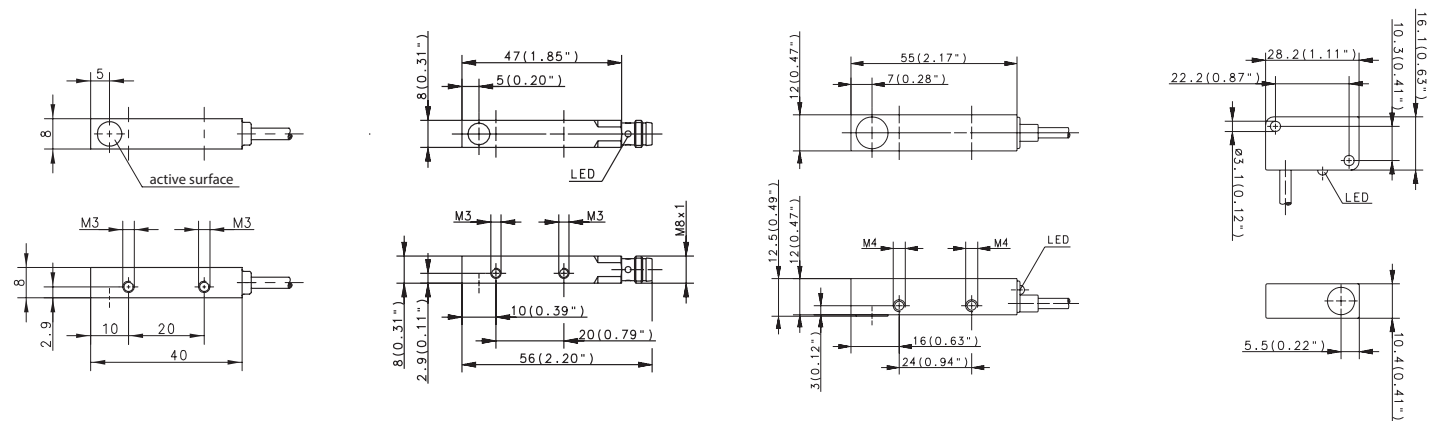

You can find detailed product data sheets at www.bernstein.eu

INDUCTIVE SENSORS Type 28x16x11 mm, 40x26x12 mm



Type			28 x 16 x 11 mm	40 x 26 x 12 mm
Enclosure material			PA, black	PBT, black
Type of installation			flush	flush
Nominal sensing distance			2 mm	2 mm
Type of connection			Connector M8	Cable 2 m
Special feature				
PNP	DC	NO contact	6502973002 KIB-E28PS/002-KLSM8	6502984023 KIB-E40PS/002-KL2
PNP	DC	NC contact	6502773001 KIB-E28PÖ/002-KLSM8	6502784006 KIB-E40PÖ/002-KL2
PNP	DC	antivalent NO/NC		
NPN	DC	NO contact		
Technical data				
Rated operating voltage range	U_B		10–30 VDC	10–36 VDC
Rated operating current	I_e		≤ 200 mA	≤ 200 mA
Max. switching voltage	F		800 Hz	800 Hz
Short circuit-protection			cyclic	cyclic
Function/operating voltage indicator			LED/–	LED/–
Mechanical data				
Ambient temperature (min/max)			–25°C/+70°C	–25°C/+70°C
Protection class in accordance with IEC 529, EN 60529			IP67	IP67
Connection			M8 x 1	3 x 0.5 mm ²

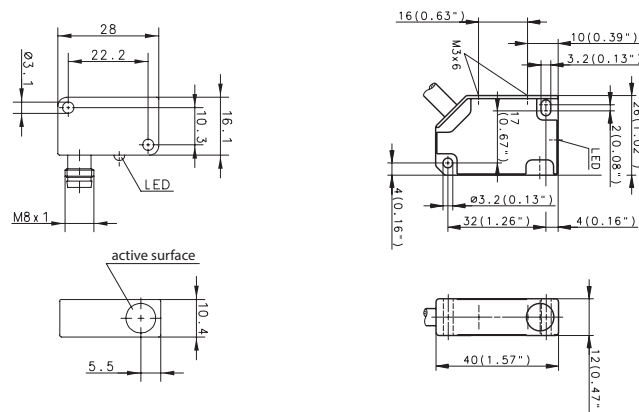

Cable couplings and other accessories can be found from p. 208

INDUCTIVE SENSORS Type 40x26x12 mm, 50x25x10 mm



Type	40 x 26 x 12 mm	40 x 26 x 12 mm	40 x 26 x 12 mm	50 x 25 x 10 mm
Enclosure material	PBT, black	PBT, black	PBT, black	PA, black
Type of installation	flush	non-flush	non-flush	flush
Nominal sensing distance	2 mm	4 mm	4 mm	5 mm
Type of connection	Connector M8	Cable 2 m	Connector M8	Cable 2 m
Special feature				
PNP	DC	NO contact	6502984025 KIB-E40PS/002-KLSM8	6502984024 KIN-E40PS/004-KL2
PNP	DC	NC contact		6502784007 KIN-E40PÖ/004-KL2
NPN	DC	NO contact		6502984026 KIN-E40PS/004-KLSM8
NPN	DC	NC contact		6502784008 KIN-E40PÖ/004-KLSM8
				6502390001 KIB-E50NS/005-KL2
Technical data				
Rated operating voltage range	U_B	10–36 VDC	10–36 VDC	10–36 VDC
Rated operating current	I_e	≤ 200 mA	≤ 200 mA	≤ 200 mA
Max. switching voltage	F	800 Hz	400 Hz	500 Hz
Short circuit-protection		cyclic	cyclic	cyclic
Function/operating voltage indicator		LED/–	LED/–	LED/–
Mechanical data				
Ambient temperature (min/max)		–25°C/+70°C	–25°C/+70°C	–25°C/+70°C
Protection class in accordance with IEC 529, EN 60529		IP67	IP67	IP67
Connection		M8 x 1	3 x 0.5 mm ²	M8 x 1

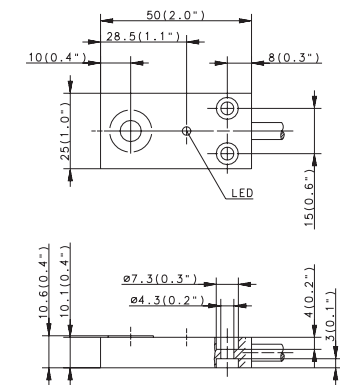
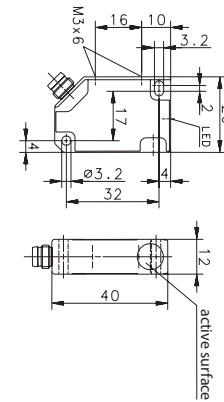
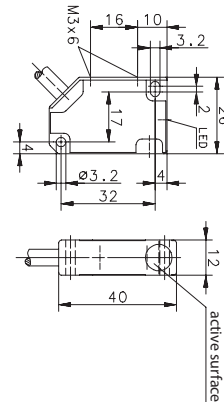
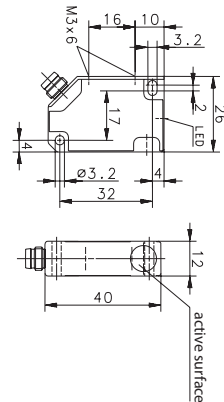

You can find detailed product data sheets at www.bernstein.eu

INDUCTIVE SENSORS Type 50x25x 10 mm, 60x36x 10 mm



Type	50 x 25 x 10 mm		50 x 25 x 10 mm		50 x 25 x 10 mm		60 x 36 x 10 mm	
Enclosure material	PA, black		PA, black		PA, black		PA, black	
Type of installation	flush		non-flush		non-flush		non-flush	
Nominal sensing distance	5 mm		8 mm		8 mm		8 mm	
Type of connection	Connector M8		Cable 2 m		Connector M8		Connector M8	
Special feature								
PNP	DC	NO contact	6502990005 KIB-E50PS/005-KLSM8	6502990003 KIN-E50PS/008-KL2	6502990006 KIN-E50PS/008-KLSM8			
PNP	DC	NC contact				6602790048 KIN-E60PÖ/008-KLSM8		
PNP	DC	antivalent NO/NC						
NPN	DC	NO contact						
Technical data								
Rated operating voltage range	U_B	10–60 VDC	10–60 VDC	10–60 VDC	10–60 VDC	10–60 VDC	10–60 VDC	
Rated operating current	I_e	≤ 200 mA	≤ 200 mA	≤ 200 mA	≤ 200 mA	≤ 200 mA	≤ 400 mA	
Max. switching voltage	F	500 Hz	200 Hz	200 Hz	200 Hz	200 Hz	200 Hz	
Short circuit-protection		cyclic	cyclic	cyclic	cyclic	cyclic	cyclic	
Function/operating voltage indicator		LED/–	LED/–	LED/–	LED/–	LED/–	LED/–	
Mechanical data								
Ambient temperature (min/max)		–25°C/+70°C	–25°C/+70°C	–25°C/+70°C	–25°C/+70°C	–25°C/+70°C	–25°C/+70°C	
Protection class in accordance with IEC 529, EN 60529		IP67	IP67	IP67	IP67	IP67	IP67	
Connection		M8 x 1	3 x 0.5 mm ²	3 x 0.5 mm ²	M8 x 1	M8 x 1	M8 x 1	

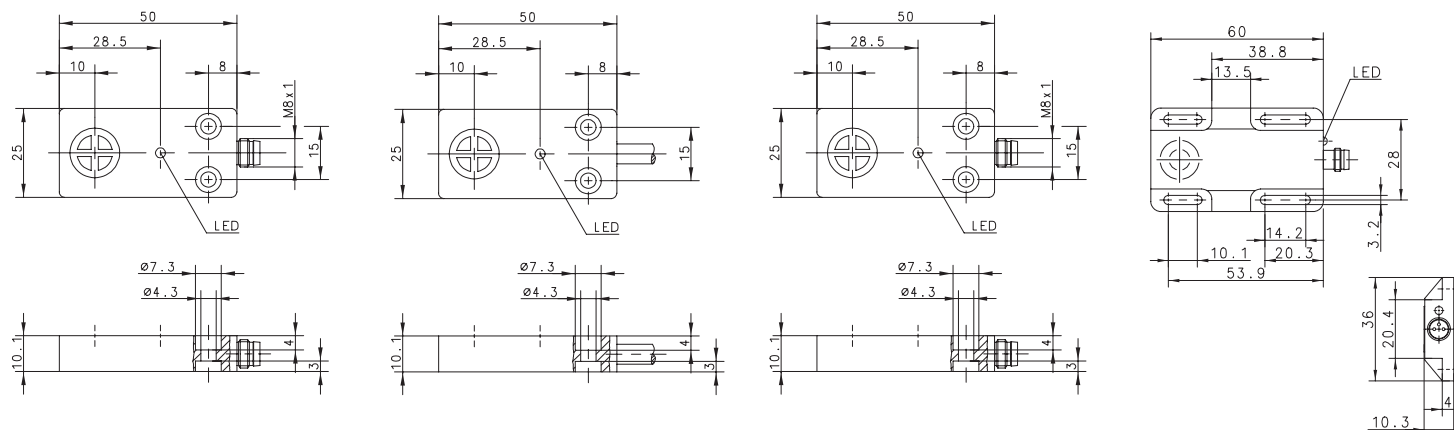

Cable couplings and other accessories can be found from p. 208

INDUCTIVE SENSORS Type 68x30x15 mm, 40x40 mm



Type	68x30x15 mm	40 x 40 mm	40 x 40 mm
Enclosure material	PBT, black	PA, red/black	PA, black
Type of installation	non-flush	non-flush	non-flush
Nominal sensing distance	7 mm	20 mm	
Type of connection	Cable 2 m	Connector M12	Cable 6 m
Special feature			Ring sensor
PNP	DC	NO contact	6502956076
			KIN-E68PS/007-KL2
PNP	DC	NC contact	6502982003
			KIN-N40PS/020-KLS12
NPN	DC	NO contact	6502999036
			KIR-N40PS/000-KL6
NPN	DC	NC contact	6502156058
			KIN-E68NÖ/007-KL6
Technical data			
Rated operating voltage range	U_B	10–60 VDC	10–36 VDC
Rated operating current	I_e	≤ 200 mA	≤ 200 mA
Max. switching voltage	F	200 Hz	50 Hz
Short circuit-protection		cyclic	cyclic
Function/operating voltage indicator		LED/–	LED/–
Mechanical data			
Ambient temperature (min/max)		–25°C/+70°C	–25°C/+70°C
Protection class in accordance with IEC 529, EN 60529		IP67	IP67
Connection		3 x 0.5 mm ²	3 x 0.5 mm ²

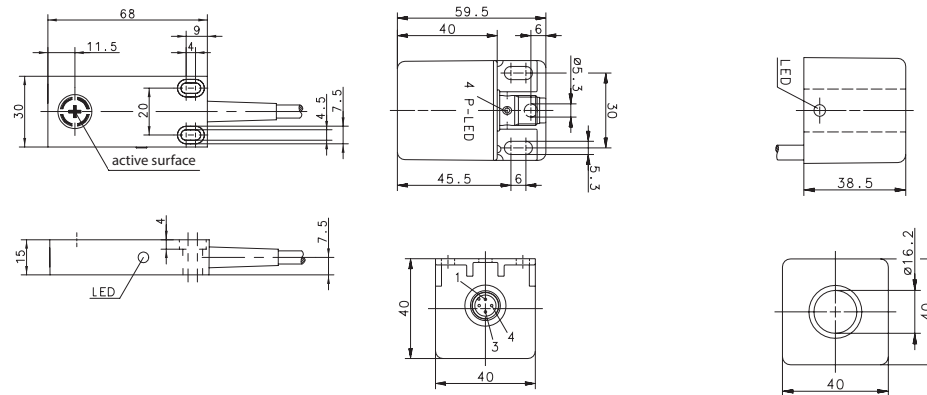

You can find detailed product data sheets at www.bernstein.eu

Inductive Sensors

NAMUR Sensors



Product features

- Metric types: M04 – M30
- Special types: Ø 34, square
- Sensing distance: 0.6 mm – 10 mm
- Switching function: NO contact and NC contact
- Enclosure material: Stainless steel and brass enclosure

Good to know ...

By using Namur sensors, short circuits and cable breaks can be detected.

Options

- Cable and connector assembly
- The enclosures can be adapted
- Product adaptations and modifications
- Customized development
- ATEX Namur sensors can be found in the "Inductive ATEX sensors" chapter

Further NAMUR sensors can be found in the EX chapter from p. 150

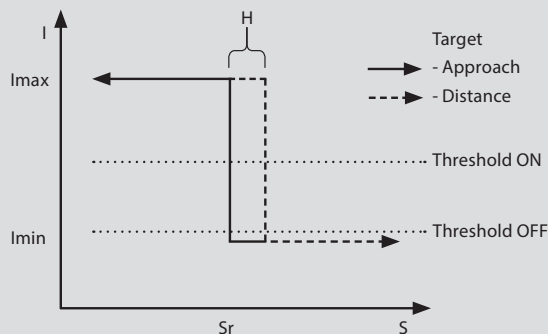

• non-continuous characteristic curve

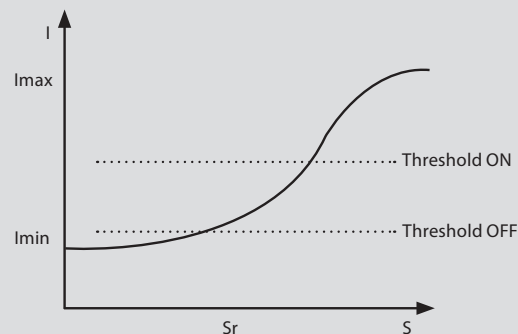

• continuous characteristic curve

INDUCTIVE SENSORS NAMUR Type M5, M8



Type	M5	M8	M8	M8
Enclosure material	CuZn39Pb3	Stainless steel 1.4305	Stainless steel 1.4305	Stainless steel 1.4305
Type of installation	flush	flush	flush	non-flush
Nominal sensing distance	1 mm	1.5 mm	2 mm	2 mm
Type of connection	Cable 2 m	Cable 2 m	Cable 2 m	Cable 2 m
Special feature	continuous characteristic curve	continuous characteristic curve	NO contact / non-contin. characteristic curve	continuous characteristic curve
NAMUR DC	6501699008 KIB-M05EA/001-2	6501601003 KIB-M08EA/1,5-2	6501601007 KIB-M08ES/002-L2	6501601005 KIN-M08EA/002-2
Technical data				
Rated operating voltage range	U_b 5–25 VDC	5–25 VDC	5–25 VDC	5–25 VDC
Rated operating current	I_e –	–	–	–
Max. switching voltage	F \approx 3 kHz	\approx 1 kHz	\approx 1.5 kHz	\approx 1 kHz
Short circuit-protection	–	–	–	–
Function/operating voltage indicator	–/–	–/–	LED/–	–/–
Mechanical data				
Ambient temperature (min/max)	–25°C/+70°C	–25°C/+70°C	–25°C/+70°C	–25°C/+70°C
Protection class in accordance with IEC 529, EN 60529	IP67	IP67	IP67	IP67
Connection	2 x 0.14 mm ²	2 x 0.25 mm ²	2 x 0.34 mm ²	2 x 0.25 mm ²

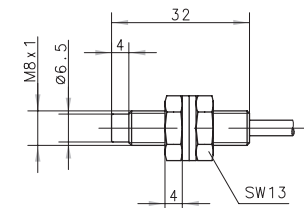
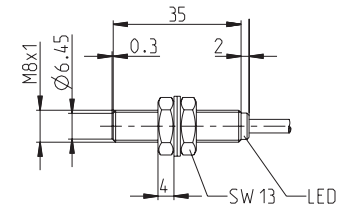
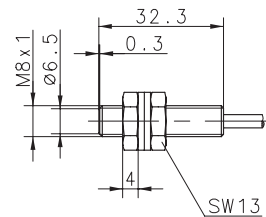
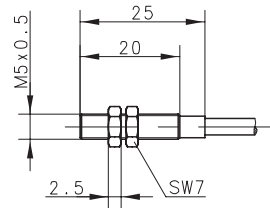

INDUCTIVE SENSORS NAMUR Type M12



Type	M12	M12	M12	M12
Enclosure material	CuZn39Pb3	CuZn39Pb3	CuZn39Pb3	CuZn39Pb3
Type of installation	flush	flush	non-flush	non-flush
Nominal sensing distance	2 mm	4 mm	4 mm	6 mm
Type of connection	Cable 2 m	Cable 2 m	Cable 2 m	Cable 2 m
Special feature	continuous characteristic curve	NO contact / non-contin. charact. curve	NC contact / non-contin. charact. curve	Sensing dist. / contin. characteristic curve
NAMUR DC	6501624760 KIB-M12EA/002-2	6501624004 KIB-M12ES/004-L2	6501625004 KIN-M12EÖ/004-KL2	
Technical data				
Rated operating voltage range	U_b 5–25 VDC	5–25 VDC	5–30 VDC	5–25 VDC
Rated operating current	I_e –	–	–	–
Max. switching voltage	F ≤ 800 Hz	≈ 1 kHz	≈ 1 kHz	≤ 200 Hz
Short circuit-protection	–	–	–	–
Function/operating voltage indicator	–/–	–/–	–/–	–/–
Mechanical data				
Ambient temperature (min/max)	–25°C/+70°C	–25°C/+70°C	–25°C/+70°C	–25°C/+70°C
Protection class in accordance with IEC 529, EN 60529	IP67	IP67	IP67	IP67
Connection	2 x 0.25 mm ²	2 x 0.34 mm ²	2 x 0.34 mm ²	2 x 0.25 mm ²

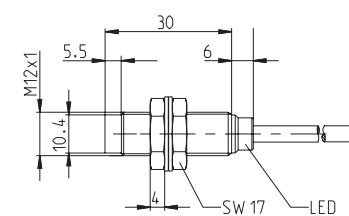
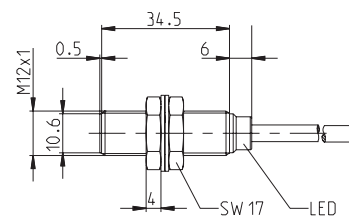
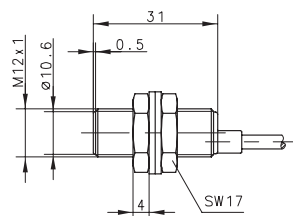

Cable couplings and other accessories can be found from p. 208

INDUCTIVE SENSORS NAMUR Type M18



Type	M18	
Enclosure material	CuZn39Pb3	
Type of installation	flush	
Nominal sensing distance	5 mm	
Type of connection	Cable 2 m	
Special feature	continuous characteristic curve	
NAMUR DC	6501626762	
	KIB-M18EA/005-2	
Technical data		
Rated operating voltage range	U_B	5–25 VDC
Rated operating current	I_e	–
Max. switching voltage	F	≤ 400 Hz
Short circuit-protection		–
Function/operating voltage indicator		–/–
Mechanical data		
Ambient temperature (min/max)		–25°C/+70°C
Protection class in accordance with IEC 529, EN 60529		IP67
Connection		2 x 0.5 mm ²

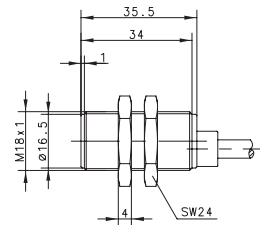

Inductive Sensors

AC-Sensors



Product features

- Metric types: M12 – M30
- Voltage range: from 20 V AC to 265 V AC
- Sensing distance: 2 mm – 20 mm
- Switching function: NO contact/NC contact
- Enclosure material: plastic, brass

Options

- Cable and connector assembly
- The enclosures can be adapted
- Product adaptations and modifications
- Customized development

INDUCTIVE SENSORS AC 2-WIRE Type M12, M18



Type	M12	M18	M18	M18
Enclosure material	CuZn39Pb3	CuZn39Pb3	PA, red	CuZn39Pb3
Type of installation	non-flush	flush	flush	non-flush
Nominal sensing distance	4 mm	5 mm	5 mm	8 mm
Type of connection	Cable 2 m	Cable 2 m	Cable 2 m	Cable 2 m
Special feature				
2-wire AC NO contact	6503504001 KIN-M12AS/004-L2	6503505004 KIB-M18AS/005-L2	6503520697 KIB-T18AS/005-L2	6503506002 KIN-M18AS/008-L2
2-wire AC NC contact	6503404001 KIN-M12AÖ/004-L2	6503405001 KIB-M18AÖ/005-L2		6503406001 KIN-M18AÖ/008-L2
Technical data				
Rated operating voltage range	U_b 76–250 V AC	20–250 V AC	24–250 V AC	20–250 V AC
Rated operating current	I_e ≤ 200 mA	≤ 400 mA	≤ 200 mA	≤ 400 mA
Max. switching voltage	F ≈ 10 Hz	≈ 10 Hz	≈ 10 Hz	≈ 10 Hz
Short circuit-protection	–	–	–	–
Function/operating voltage indicator	LED/–	LED/–	LED/–	LED/–
Mechanical data				
Ambient temperature (min/max)	–25°C/+70°C	–25°C/+70°C	–25°C/+70°C	–25°C/+70°C
Protection class in accordance with IEC 529, EN 60529	IP67	IP67	IP67	IP67
Connection	2 x 0.14 mm ²	2 x 0.5 mm ²	2 x 0.5 mm ²	2 x 0.5 mm ²

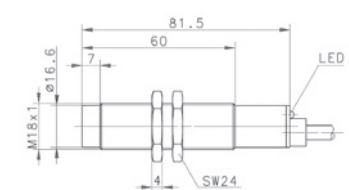
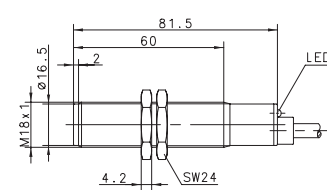
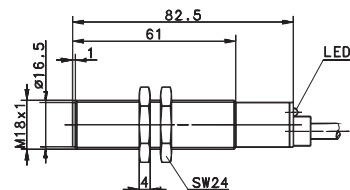
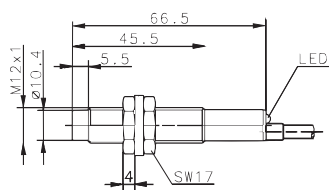

INDUCTIVE SENSORS AC 2-WIRE Type M18, M30



Type	M18	M30	M30	M30
Enclosure material	PA, red	CuZn39Pb3	CuZn39Pb3	CuZn39Pb3
Type of installation	non-flush	flush	flush	non-flush
Nominal sensing distance	8 mm	10 mm	10 mm	15 mm
Type of connection	Cable 2 m	Cable 2 m	DIN Connector	Cable 2.5 m
Special feature				
2-wire AC NO contact	6503521705 KIN-T18AS/008-L2	6503507378 KIB-M30AS/010-L2	6503535960 KIB-M30AS/010-LSD	6503508246 KIN-M30AS/015-L2,5
2-wire AC NC contact	6503421704 KIN-T18AÖ/008-L2	6503407240 KIB-M30AÖ/010-L2	6503435959 KIB-M30AÖ/010-LSD	
Technical data				
Rated operating voltage range	U_b 24–250 V AC	20–250 V AC	20–265 V AC	20–250 V AC
Rated operating current	I_e ≤ 200 mA	≤ 400 mA	≤ 500 mA	≤ 400 mA
Max. switching voltage	F ≈ 10 Hz	≈ 10 Hz	20 Hz	≈ 10 Hz
Short circuit-protection	–	–	–	–
Function/operating voltage indicator	LED/–	LED/–	LED/–	LED/–
Mechanical data				
Ambient temperature (min/max)	–25°C/+70°C	–25°C/+70°C	–25°C/+70°C	–25°C/+70°C
Protection class in accordance with IEC 529, EN 60529	IP67	IP67	IP65	IP67
Connection	2 x 0.5 mm ²	2 x 0.5 mm ²	Plug connector DIN EN 175301-803	2 x 0.5 mm ²

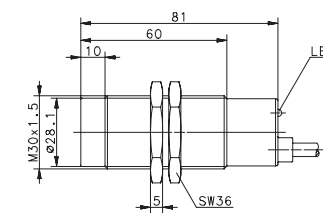
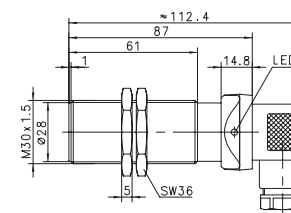
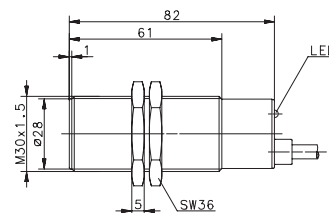
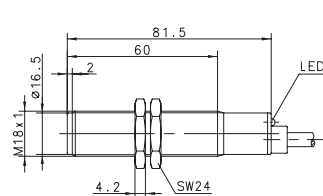

Cable couplings and other accessories can be found from p. 208

INDUCTIVE SENSORS AC 2-WIRE Type M30



Type	M30	
Enclosure material	PA, red	
Type of installation	non-flush	
Nominal sensing distance	15 mm	
Type of connection	Cable 2.5 m	
Special feature		
2-wire AC NO contact	6503523956 KIN-T30AS/015-L2,5	
2-wire AC NC contact		
Technical data		
Rated operating voltage range	U_B	20–250 V AC
Rated operating current	I_e	≤ 400 mA
Max. switching voltage	F	≈ 10 Hz
Short circuit-protection	–	
Function/operating voltage indicator	LED/–	
Mechanical data		
Ambient temperature (min/max)	–25°C/+70°C	
Protection class in accordance with IEC 529, EN 60529	IP67	
Connection	2 x 0.5 mm ²	

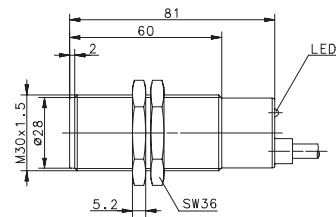

Inductive Sensors

Analogue Sensors



Product features

- Metric types: M18/M30
- Sensing distance: 8 mm – 15 mm
- Current output: 0 – 10 mA/0 – 20 mA
- Enclosure material: Brass

Options

- Cable and connector assembly
- Adaptation of the enclosures
- Product adaptations and modifications
- Customized development

INDUCTIVE SENSORS ANALOGUE Type M18



Type	M18	M18
Enclosure material	CuZn39Pb3	CuZn39Pb3
Type of installation	non-flush	non-flush
Nominal sensing distance	8 mm	8 mm
Type of connection	Cable 2 m	Connector M12
Special feature		
Analogue DC	6502006001	6602006111
	KIN-M18PA/008-2	KIN-M18PA/008-S12
Technical data		
Rated operating voltage range	U_b	10–36 VDC
Rated operating current	I_e	–
Max. switching voltage	F	–
Short circuit-protection		cyclic
Function/operating voltage indicator		–/–
Mechanical data		
Ambient temperature (min/max)		–25°C/+70°C
Protection class in accordance with IEC 529, EN 60529		IP67
Connection		3 x 0.5 mm ²

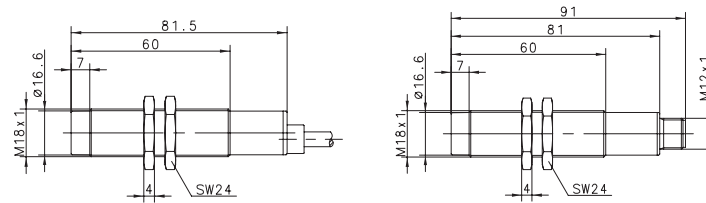

Inductive Sensors

ATEX Sensors



Product features

- Metric types: M05 – M30
- Sensing distance: 1 mm – 15 mm
- Switching function: NO contact/NC contact, NAMUR
- Enclosure material: plastic, brass, stainless steel

Good to know ...

The term: "ATEX" is a derivative of **Atmosphères Explosibles**, which is French for explosive atmosphere.



INDUCTIVE SENSORS ATEX Type M08, M12



Type	M08	M08	M08	M12	
Enclosure material	Stainless steel 1.4305	Stainless steel 1.4305	Stainless steel 1.4305	CuZn39Pb3	
Type of installation	flush	flush	non-flush	flush	
Nominal sensing distance	1.5 mm	1 mm	2 mm	2 mm	
Type of connection	Cable 2 m	Cable 2 m	Cable 2 m	Cable 2 m	
ATEX	II 3 G Ex ib IIC T6 Gc II 3 D Ex ib IIIC T70°C Dc	II 2 D Ex tb IIIC T100°C Db	II 2 D Ex tb IIIC T100°C Db	II 2 D Ex tb IIIC T100°C Db	
Special feature	NAMUR				
NPN	DC	NO contact	6522302025 KIB-M08NS/001-KL2D	6522302040 KIN-M08NS/002-KL2D	6522303029 KIB-M12NS/002-KL2D
NPN	DC	NC contact	6522102024 KIB-M08NÖ/001-KL2D	6522102039 KIN-M08NÖ/002-KL2D	6522103028 KIB-M12NÖ/002-KL2D
PNP	DC	NO contact	6522902027 KIB-M08PS/001-KL2D	6522902042 KIN-M08PS/002-KL2D	6522903022 KIB-M12PS/002-KL2D
PNP	DC	NC contact	6522702026 KIB-M08PÖ/001-KL2D	6522702041 KIN-M08PÖ/002-KL2D	6522703030 KIB-M12PÖ/002-KL2D
DC	6521601003 KIB-M08EA/1,5-2G				
Technical data					
Rated operating voltage range	U_b	5–25 VDC	10–30 VDC	10–30 VDC	10–30 VDC
Rated operating current	I_e	–	≤ 200 mA	≤ 200 mA	≤ 200 mA
Max. switching voltage	F	≈ 1 kHz	≈ 1 kHz	750 Hz	800 Hz
Short circuit-protection		–	cyclic	cyclic	cyclic
Function/operating voltage indicator		–/–	LED	LED	LED
Mechanical data					
Ambient temperature (min/max)		–20°C/+60°C	–20°C/+60°C	–20°C/+60°C	–20°C/+60°C
Protection class in accordance with IEC 529, EN 60529		IP67	IP67	IP67	IP67
Connection		2 x 0.25 mm ²	3 x 0.14 mm ²	3 x 0.14 mm ²	3 x 0.14 mm ²

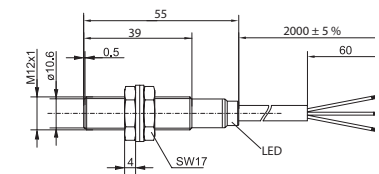
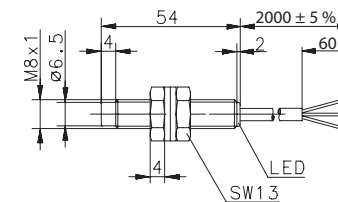
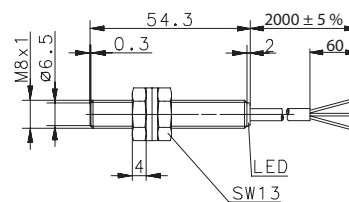
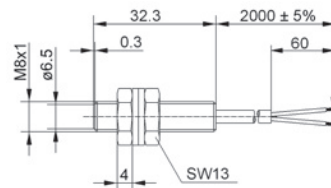

You can find detailed product data sheets at www.bernstein.eu

INDUCTIVE SENSORS ATEX Type M12, M18



Type	M12	M18	M18	M18	
Enclosure material	CuZn39Pb3	CuZn39Pb3	CuZn39Pb3	CuZn39Pb3	
Type of installation	non-flush	flush	flush	flush	
Nominal sensing distance	4 mm	5 mm	5 mm	5 mm	
Type of connection	Cable 2 m	Cable 2 m	Connector M12	Cable 2 m	
ATEX	II 2 D Ex tb IIIC T100°C Db	II 3G Ex nA IIC T6 Gc X II 3D Ex tc IIIC T80°C Dc X	II 3G Ex nA IIC T6 Gc X II 3D Ex tc IIIC T80°C Dc X	II 2 D Ex tb IIIC T100°C Db	
Special feature					
NPN	DC	NO contact	6522304044 KIN-M12NS/004-KL2D	6522305032 KIB-M18NS/005-KL2D	
NPN	DC	NC contact	6522104043 KIN-M12NÖ/004-KL2D	6522105031 KIB-M18NÖ/005-KL2D	
PNP	DC	NO contact	6522904023 KIN-M12PS/004-KL2D	6522905013 KIB-M18PS/005-KL2D	
PNP	DC	NC contact	6522704045 KIN-M12PÖ/004-KL2D	6522905015 KIB-M18PS/005-KLS12D	
				6522905034 KIB-M18PS/005-KL2D	
				6522705033 KIB-M18PÖ/005-KL2D	
DC					
Technical data					
Rated operating voltage range	U_B	10–30 VDC	10–36 VDC	10–36 VDC	10–30 VDC
Rated operating current	I_e	≤ 200 mA	≤ 200 mA	200 mA	≤ 200 mA
Max. switching voltage	F	450 Hz	500 Hz	500 Hz	500 Hz
Short circuit-protection		cyclic	cyclic	cyclic	cyclic
Function/operating voltage indicator		LED	LED	LED	LED
Mechanical data					
Ambient temperature (min/max)		–20°C/+60°C	–20°C/+60°C	–25°C/+60°C	–20°C/+60°C
Protection class in accordance with IEC 529, EN 60529		IP67	IP67	IP67	IP67
Connection		3 x 0.14 mm ²	3 x 0.5 mm ²	M12 x 1	3 x 0.34 mm ²

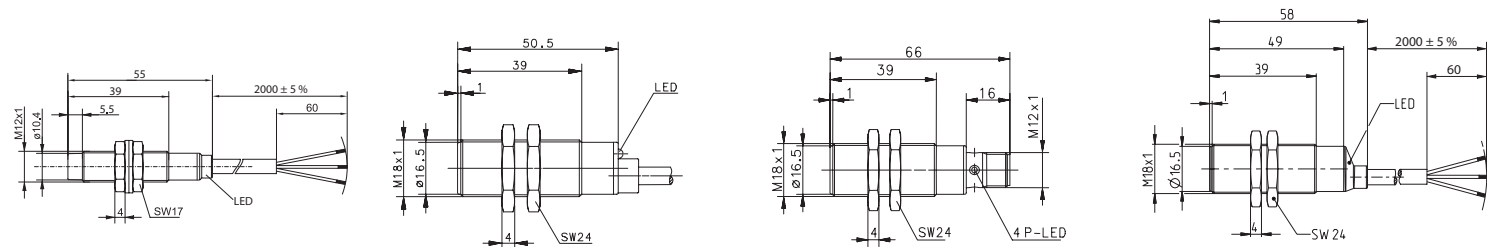

Cable couplings and other accessories can be found from p. 208



Type	M18	M18	M30	M30	
Enclosure material	CuZn39Pb3	CuZn39Pb3	CuZn39Pb3	CuZn39Pb3	
Type of installation	non-flush	non-flush	flush	flush	
Nominal sensing distance	8 mm	8 mm	10 mm	10 mm	
Type of connection	Cable 2 m	Cable 2 m	Cable 2 m	Connector M12	
ATEX	II 3G Ex ib IIC T6 Gc II 3D Ex i IIIC T70°C Dc	II 2 D Ex tb IIIC T100°C Db	II 2 D Ex tb IIIC T100°C Db	II 3G Ex nA IIC T6 Gc X II 3D Ex tc IIIC T80°C Dc X	
Special feature	NAMUR				
NPN DC NO contact	6522306047 KIN-M18NS/008-KL2D		6522307036 KIB-M30NS/010-KL2D		
NPN DC NC contact	6522106046 KIN-M18NÖ/008-KL2D		6522107035 KIB-M30NÖ/010-KL2D		
PNP DC NO contact	6522906049 KIN-M18PS/008-KL2D		6522907038 KIB-M30PS/010-KL2D		
PNP DC NC contact	6522706048 KIN-M18PÖ/008-KL2D		6522707037 KIB-M30PÖ/010-KL2D		
DC	6521627001 KIN-M18EA/008-2G				
Technical data					
Rated operating voltage range	U_b	5–25 VDC	10–30 VDC	10–30 VDC	10–36 VDC
Rated operating current	I_e	–	≤ 200 mA	≤ 200 mA	200 mA
Max. switching voltage	F	200 Hz	200 Hz	300 Hz	300 Hz
Short circuit-protection		–	cyclic	cyclic	cyclic
Function/operating voltage indicator		–/–	LED	LED	LED
Mechanical data					
Ambient temperature (min/max)		–25°C/+60°C	–20°C/+60°C	–20°C/+60°C	–25°C/+60°C
Protection class in accordance with IEC 529, EN 60529		IP67	IP67	IP67	IP67
Connection		2 x 0.5 mm ²	3 x 0.34 mm ²	3 x 0.34 mm ²	M12 x 1

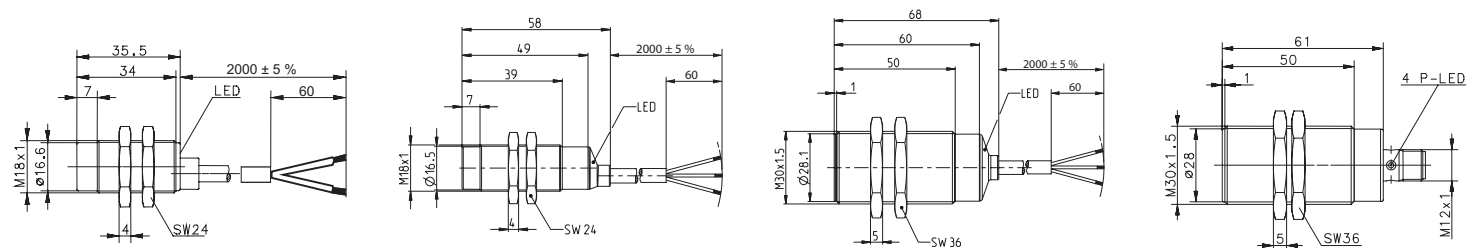

INDUCTIVE SENSORS ATEX Type M30



Type	M30
Enclosure material	CuZn39Pb3
Type of installation	non-flush
Nominal sensing distance	15 mm
Type of connection	Cable 2 m
ATEX	II 2 D Ex tb IIIC T100°C Db
Special feature	

NPN	DC	NO contact	6522308051 KIN-M30NS/015-KL2D
NPN	DC	NC contact	6522108050 KIN-M30NÖ/015-KL2D
PNP	DC	NO contact	6522908053 KIN-M30PS/015-KL2D
PNP	DC	NC contact	6522708052 KIN-M30PÖ/015-KL2D

DC

Technical data		
Rated operating voltage range	U_b	10–30 VDC
Rated operating current	I_e	≤ 200 mA
Max. switching voltage	F	100 Hz
Short circuit-protection		cyclic
Function/operating voltage indicator		LED

Mechanical data		
Ambient temperature (min/max)		–20°C/+60°C
Protection class in accordance with IEC 529, EN 60529		IP67
Connection		3 x 0.34 mm ²

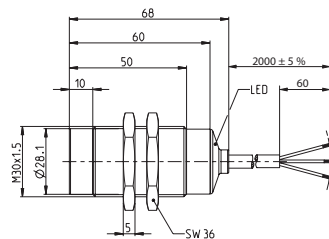

Cable couplings and other accessories can be found from p. 208



Capacitive Sensors

Standard range



Product features

- Metric types: metric M12 – M30
- Special types: smooth cylindrical, rectangular
- Sensing distance: 2 mm – 30 mm
- Switching function: NO contact, NC contact, Dual output, Changeover contact
- Enclosure material: brass and plastic enclosure
- Medium: conductive and non-conductive materials
solid, liquid, granular or powder
- Time delay: Switch-on and switch-off delay

Good to know ...

The capacitive sensors have in principle a potentiometer integrated, which allows the response sensitivity, i.e. the switching distance to the medium, to be adjusted. Optionally, the sensors can also be preset or can be delivered without a potentiometer.

Options

- Cable and connector assembly
- The enclosures can be adapted
- Product adaptations and modifications
- Customized development

Application descriptions

A special application of the capacitive proximity switch is to detect fill levels in non-metallic containers from the outside.

Advantage: The container wall does not have to be broken through for scanning. A prerequisite for this is that the dielectric constant and the mass of the material to be scanned is greater than that of the container. The response sensitivity of the proximity switch must be reduced with the built-in potentiometer to such an extent that the limit switch does not respond to the container wall but to the medium to be scanned.

Adhesion of the medium to the sensor head is a common challenge when capacitive sensors come into direct contact with the medium. This can lead to false switching signals. In these applications, sensors with PTFE front cap should be used.

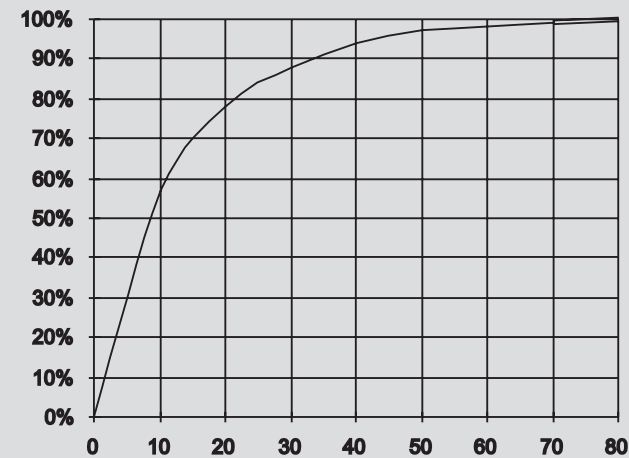

Variance of sensing distance as a function of ϵ

Examples of dielectric constants

Glass	3 ... 14
Rubber	2.5 ... 3
Laminated paper	3.5 ... 6
Wood	2.5 ... 6.8
Marble	8.4 ... 14
Mineral oil	2.15
Epoxy resin	3.3 ... 3.6
Petroleum	2.2
Plexiglas	3.6
Polyamide	3 ... 8
PVC	3.3 ... 4.1
Porcelain	4.2 ... 6.5
Teflon PTFE	2
Air	1
Water	80.8
Paper (dry)	2

Capacitive Sensors

Standard range

Level monitoring in
non-metallic containers

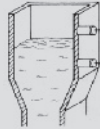

Level monitoring of bulk material,
e.g. granulated material, fodder

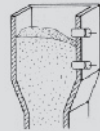

Stack height scanning, e.g. paper, chip board

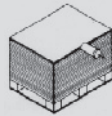

Fill level monitoring in paint and
adhesive containers

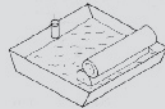

Registering, counting, sorting or
monitoring in conveyor belt systems

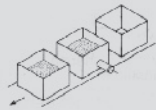

Detecting, positioning in
sequence control systems

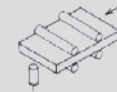

Detection in woodworking applications

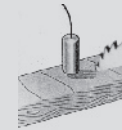

Belt breakage signalling

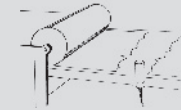

Level monitoring in
packing systems

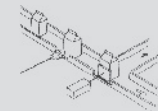



CAPACITIVE SENSORS Type M12



Type	M12	M12	M12	M12		
Enclosure material	CuZn39Pb3	PBT, black	PBT, black	PBT, black		
Type of installation	flush	non-flush	non-flush	non-flush		
Nominal sensing distance	2 mm	4 mm	4 mm	6 mm		
Type of connection	Cable 2 m	Cable 2 m	Connector M8	Cable 2 m		
Special feature	PTFE Front cap			Sensing distance		
PNP	DC	NO contact	6507903001 KCB-M12PS/002-KLP2	6507919001 KCN-T12PS/004-KLP2	6507919004 KCN-T12PS/004-KLSM8	6607919110 KCN-T12PS/006-KLP2E
PNP	DC	NC contact				
NPN	DC	NO contact				
NPN	DC	NC contact				
Technical data						
Rated operating voltage range	U_B	10–36 VDC	10–36 VDC	10–36 VDC	10–36 VDC	10–36 VDC
Rated operating current	I_e	≤ 200 mA	≤ 200 mA	≤ 200 mA	≤ 200 mA	≤ 200 mA
Switching frequency (max)	F	25 Hz	25 Hz	25 Hz	25 Hz	25 Hz
Short circuit-protection		cyclic	cyclic	cyclic	cyclic	cyclic
Function/operating voltage indicator		LED/–	LED/–	LED/–	LED/–	LED/–
Sensing distance, adjustable		Poti	Poti	–	–	Poti
Mechanical data						
Ambient temperature (min/max)		–25°C/+70°C	–25°C/+70°C	–25°C/+70°C	–25°C/+70°C	–25°C/+70°C
Protection class in accordance with IEC 529, EN 60529		IP65	IP65	IP65	IP65	IP65
Connection		3 x 0.14 mm ²	3 x 0.14 mm ²	M8 x 1	M8 x 1	3 x 0.14 mm ²

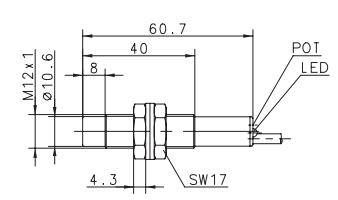
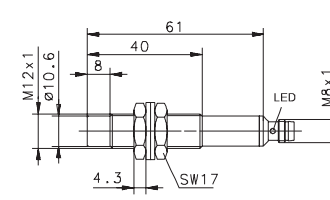
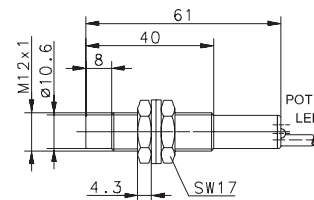
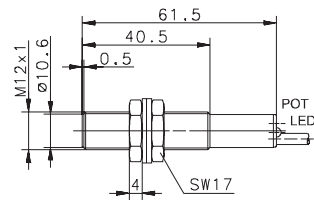

Cable couplings and other accessories can be found from p. 208

CAPACITIVE SENSORS Type M18



Type	M18	M18	M18	M18
Enclosure material	CuZn39Pb3	CuZn39Pb3	PBT, black	PBT, black
Type of installation	flush	flush	non-flush	non-flush
Nominal sensing distance	5 mm	5 mm	8 mm	8 mm
Type of connection	Cable 2 m	Connector M8	Cable 2 m	Connector M8
Special feature	PTFE Front cap	PTFE Front cap		
PNP	DC	NO contact	6507905001 KCB-M18PS/005-KLP2	6507905004 KCB-M18PS/005-KLP5M8
PNP	DC	NC contact	6507921724 KCN-T18PS/008-KLP2	6507921002 KCN-T18PS/008-KLP5M8
PNP	DC	antivalent NO/NC		
NPN	DC	NO contact	6507321723 KCN-T18NS/008-KLP2	
Technical data				
Rated operating voltage range	U_B	10–60 VDC	10–60 VDC	10–60 VDC
Rated operating current	I_e	≤ 200 mA	≤ 200 mA	≤ 200 mA
Switching frequency (max)	F	25 Hz	25 Hz	25 Hz
Short circuit-protection		cyclic	cyclic	cyclic
Function/operating voltage indicator		LED/LED	LED/LED	LED/LED
Sensing distance, adjustable		Poti	Poti	Poti
Mechanical data				
Ambient temperature (min/max)		–25°C/+70°C	–25°C/+70°C	–25°C/+70°C
Protection class in accordance with IEC 529, EN 60529		IP65	IP65	IP65
Connection		3 x 0.5 mm ²	M8 x 1	3 x 0.5 mm ²

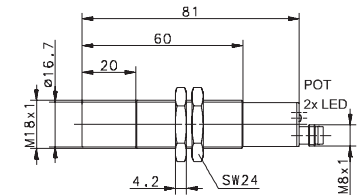
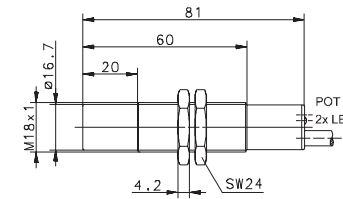
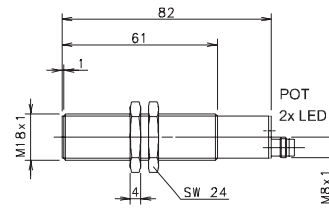
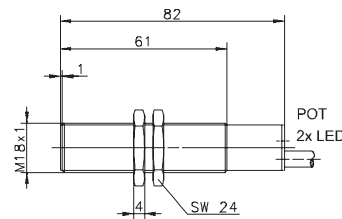

CAPACITIVE SENSORS Type M18, M30



Type	M18	M18	M30	M30
Enclosure material	PBT, black	PBT, black	CuZn39Pb3	CuZn39Pb3
Type of installation	non-flush	non-flush	flush	flush
Nominal sensing distance	13,5 mm	13,5 mm	10 mm	10 mm
Type of connection	Cable 3 m	Connector M12	Cable 2 m	Connector M12
Special feature	Sensing distance	Sensing distance/Short type	PTFE Front cap	PTFE Front cap
PNP	DC	NO contact	6507921461	6507921004
			KCN-T18PS/013-KLP3	KCN-T18PS/013-KLPS12V
PNP	DC	NC contact	6507907001	6507707001
			KCB-M30PS/010-KLP2	KCB-M30PÖ/010-KLP2
NPN	DC	NO contact		
NPN	DC	NC contact		
Technical data				
Rated operating voltage range	U_B	10–60 VDC	10–60 VDC	10–60 VDC
Rated operating current	I_e	≤ 200 mA	≤ 200 mA	≤ 400 mA
Switching frequency (max)	F	25 Hz	25 Hz	25 Hz
Short circuit-protection		cyclic	cyclic	cyclic
Function/operating voltage indicator		LED/LED	LED/LED	LED/LED
Sensing distance, adjustable		Poti	Poti	Poti
Mechanical data				
Ambient temperature (min/max)		–25°C/+70°C	–25°C/+70°C	–25°C/+70°C
Protection class in accordance with IEC 529, EN 60529		IP65	IP65	IP65
Connection		3 x 0.5 mm ²	M12 x 1	3 x 0.5 mm ²

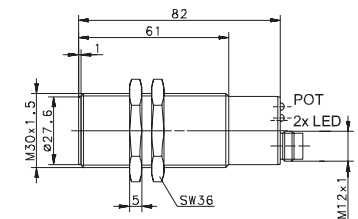
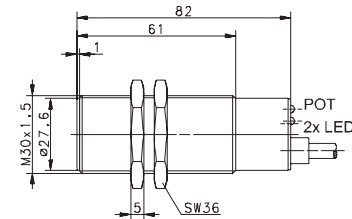
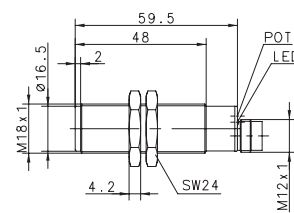
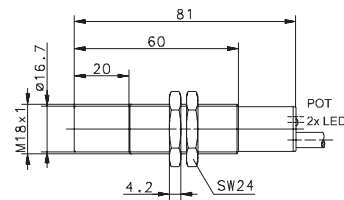

Cable couplings and other accessories can be found from p. 208

CAPACITIVE SENSORS Type M30



Type	M30	M30	M30	M30
Enclosure material	Stainless steel 1.4305	PBT, black	PBT, black	PBT, black
Type of installation	non-flush	non-flush	non-flush	non-flush
Nominal sensing distance	20 mm	20 mm	20 mm	20 mm
Type of connection	Cable 2 m	Cable 2 m	Connector M12	Cable 2 m
Special feature	PTFE Front cap / Stainless steel enclosure		Short type	Pickup delay / Relais
PNP	DC	NO contact	6507908001 KCN-M30PS/020-KLP2	6507923727 KCN-T30PS/020-KLP2
PNP	DC	NC contact		6507723001 KCN-T30PÖ/020-KLP2
NPN	DC	NO contact	6507308001 KCN-M30NS/020-KLP2	6507323001 KCN-T30NS/020-KLP2
NPN	DC	NC contact		
Relay	Changeover contact			6509023001 KCN-T30RU/020-LP2
Technical data				
Rated operating voltage range	U_B	10–60 VDC	10–60 VDC	10–60 VDC
Rated operating current	I_e	≤ 400 mA	≤ 400 mA	≤ 400 mA
Switching frequency (max)	F	25 Hz	25 Hz	25 Hz
Short circuit-protection		cyclic	cyclic	cyclic
Function/operating voltage indicator		LED/LED	LED/LED	LED/LED
Sensing distance, adjustable		Poti	Poti	Poti
Mechanical data				
Ambient temperature (min/max)		–25°C/+70°C	–25°C/+70°C	–25°C/+70°C
Protection class in accordance with IEC 529, EN 60529		IP67	IP65	IP65
Connection		3 x 0.5 mm ²	3 x 0.5 mm ²	M12 x 1

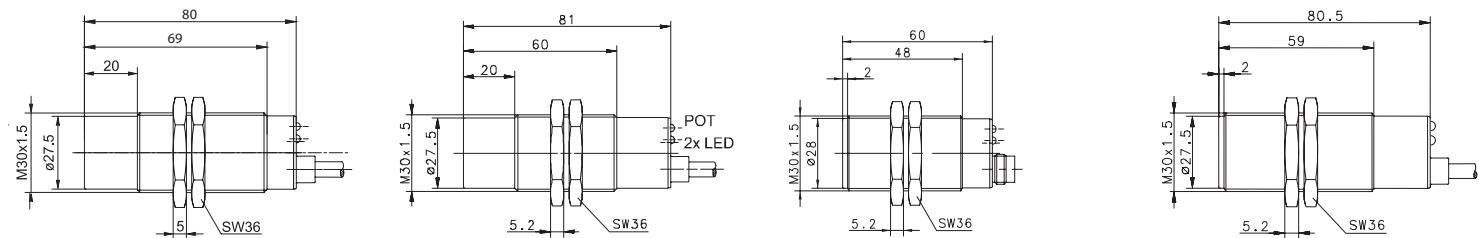

You can find detailed product data sheets at www.bernstein.eu

CAPACITIVE SENSORS Type M30, M32



Type	M30	M32	M32	M32	
Enclosure material	PBT, black	CuZn39Pb3	CuZn39Pb3	PBT, black	
Type of installation	non-flush	flush	flush	non-flush	
Nominal sensing distance	20 mm	15 mm	15 mm	30 mm	
Type of connection	Connector M12	Cable 2 m	Connector M12	Cable 2 m	
Special feature		PTFE Front cap	PTFE Front cap		
PNP	DC	NO contact	6507923004 KCN-T30PS/020-KLPS12		
NPN	DC	NO contact			
PNP/NPN	DC	NO/NC prog.	6507013011 KCB-M32DP/015-KLP2	6507013015 KCB-M32DP/015-KLPS12	6507013001 KCN-T32DP/030-KLP2
PNP/NPN	DC	Push-pull operation	6507013012 KCB-M32GP/015-KLP2		
Technical data					
Rated operating voltage range	U_B	10–60 VDC	10–60 VDC	10–60 VDC	10–60 VDC
Rated operating current	I_e	≤ 400 mA	≤ 400 mA	≤ 400 mA	≤ 400 mA
Switching frequency (max)	F	25 Hz	25 Hz	25 Hz	25 Hz
Short circuit-protection		cyclic	cyclic	cyclic	cyclic
Function/operating voltage indicator		LED/LED	LED/LED	LED/–	LED/–
Sensing distance, adjustable		Poti	Poti	Poti	Poti
Mechanical data					
Ambient temperature (min/max)		–25°C/+70°C	–25°C/+70°C	–25°C/+70°C	–25°C/+70°C
Protection class in accordance with IEC 529, EN 60529		IP65	IP67	IP65	IP65
Connection		M12 x 1	3 x 0.5 mm ²	M12 x 1	3 x 0.5 mm ²

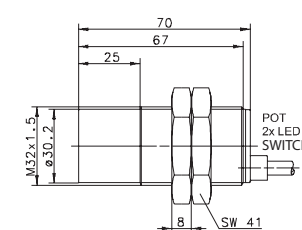
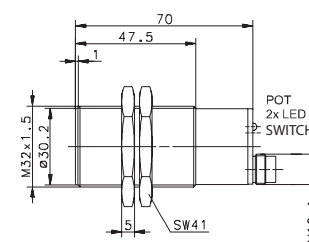
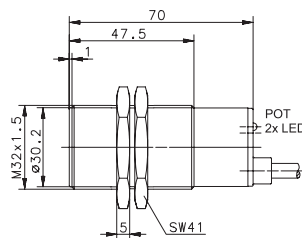
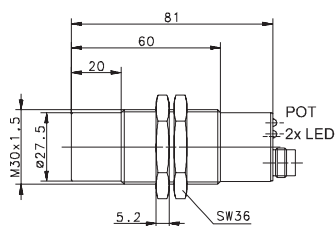

Cable couplings and other accessories can be found from p. 208

CAPACITIVE SENSORS Type M32



Type	M32
Enclosure material	PBT, black
Type of installation	non-flush
Nominal sensing distance	30 mm
Type of connection	Connector M12
Special feature	

PNP DC NO contact

NPN DC NO contact

PNP/NPN DC NO/NC prog. **6507013004**
KCN-T32DP/030-KLPS12

PNP/NPN DC Push-pull operation

Technical data		
Rated operating voltage range	U_B	10–60 VDC
Rated operating current	I_e	≤ 400 mA
Switching frequency (max)	F	25 Hz
Short circuit-protection		cyclic
Function/operating voltage indicator		LED/–
Sensing distance, adjustable		Poti

Mechanical data	
Ambient temperature (min/max)	–25°C/+70°C
Protection class in accordance with IEC 529, EN 60529	IP65
Connection	M12 x 1

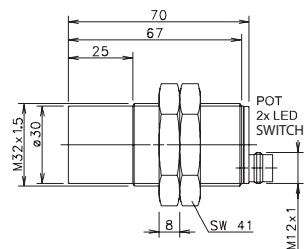

CAPACITIVE SENSORS Type Ø 34 mm



Type	Ø 34 mm	Ø 34 mm	Ø 34 mm
Enclosure material	CuZn39Pb3	PBT, red	PBT, red
Type of installation	flush	non-flush	non-flush
Nominal sensing distance	20 mm	30 mm	30 mm
Type of connection	Connector M12	Cable 2 m	Connector M12
Special feature			
PNP	DC	NO contact	6507915006 KCB-D34PS/020-KLPS12
PNP	DC	NC contact	6507915001 KCN-R34PS/030-KLP2
NPN	DC	NO contact	6507915004 KCN-R34PS/030-KLPS12
NPN	DC	NC contact	6507715004 KCN-R34PÖ/030-KLPS12
Technical data			
Rated operating voltage range	U_B	10–60 VDC	10–60 VDC
Rated operating current	I_e	≤ 200 mA	≤ 400 mA
Switching frequency (max)	F	25 Hz	25 Hz
Short circuit-protection		cyclic	cyclic
Function/operating voltage indicator		LED/LED	LED/LED
Sensing distance, adjustable		Poti	Poti
Mechanical data			
Ambient temperature (min/max)		–25°C/+70°C	–25°C/+70°C
Protection class in accordance with IEC 529, EN 60529		IP65	IP65
Connection		M12 x 1	3 x 0.5 mm ² M12 x 1

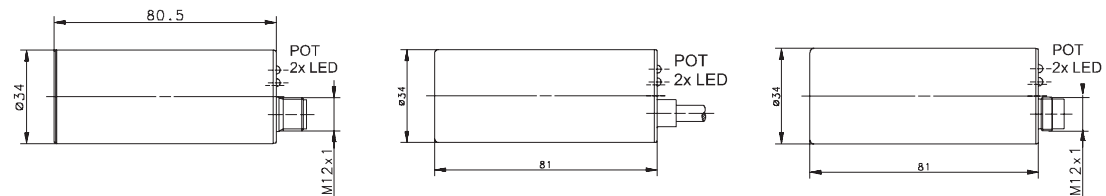

Cable couplings and other accessories can be found from p. 208

Type			15 x 25 x 10 mm	15 x 25 x 10 mm
Enclosure material			PBT, black	PBT, black
Type of installation			flush	flush
Nominal sensing distance			8 mm	8 mm
Type of connection			Cable 2 m	Connector M8
Special feature				
PNP	DC	NO contact	6507990001 KCB-E50PS/008-KLP2	6607990842 KCB-E50PS/008-KLPSM8
PNP	DC	NC contact		
NPN	DC	NO contact		
NPN	DC	NC contact		
Technical data				
Rated operating voltage range	U_B		10–36 VDC	10–36 VDC
Rated operating current	I_e		≤ 200 mA	≤ 200 mA
Switching frequency (max)	F		25 Hz	25 Hz
Short circuit-protection			cyclic	cyclic
Function/operating voltage indicator			LED/–	LED/–
Sensing distance, adjustable			Poti	Poti
Mechanical data				
Ambient temperature (min/max)			–25°C/+70°C	–25°C/+70°C
Protection class in accordance with IEC 529, EN 60529			IP65	IP65
Connection			3 x 0.34 mm ²	M8 x 1

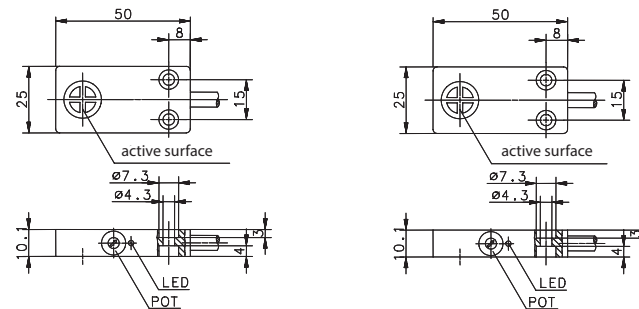

Capacitive Sensors

NAMUR-Sensors

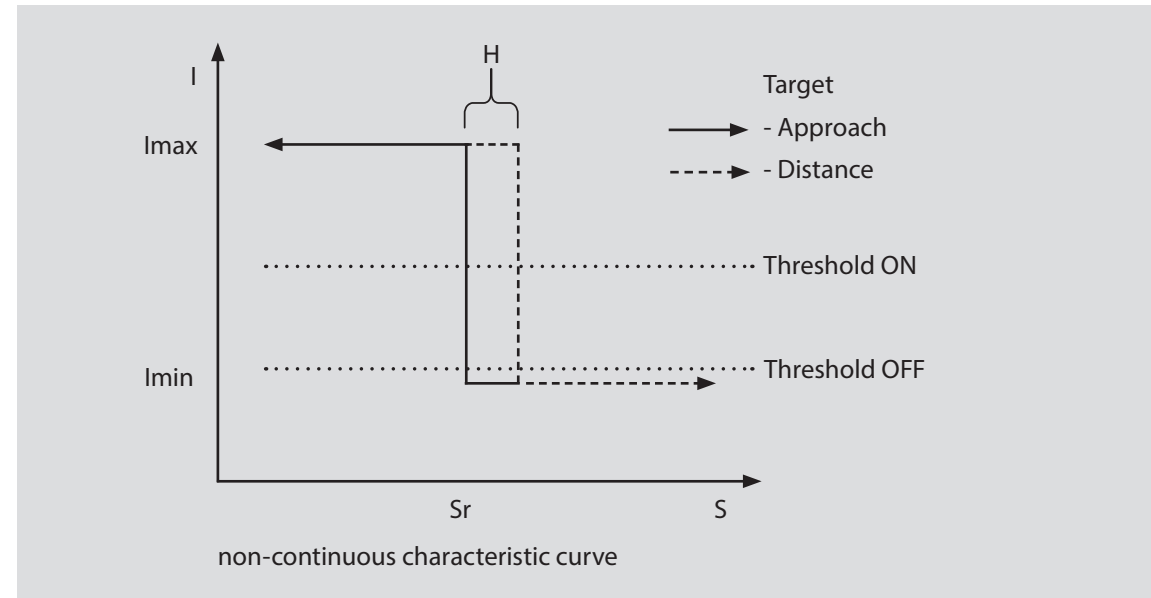
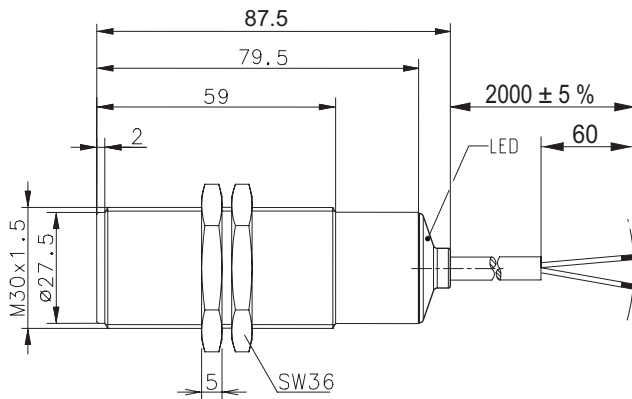

Good to know ...

By using Namur sensors, short circuits and cable breaks can be detected.

Technical data NAMUR Type M30

NAMUR DC		6506623001	KCN-T30ES/015-L2
Electrical data			
Type of installation	S_n	non-flush	
Nominal sensing distance		15 mm (Characteristic curve acc. to DIN EN 60947-5-6, 5.4 Fig. 2)	
Standard measuring plate		45 mm x 45 mm x 1 mm, material: Fe	
Assured switching distance	S_a	0 ... 12 mm	
Repeatability	R	< 5 %	
Nominal voltage	U_n	DC 8 V	
Rated operating voltage	U_e	DC 5 ... 25 V	
Ripple		≤ 5 %	
Power consumption	I	> 3.5 mA ($U_n = 8\text{ V}$ und $R_i = 1\text{ k}\Omega$) sensing face damping < 1.2 mA ($U_n = 8\text{ V}$ und $R_i = 1\text{ k}\Omega$) sensing face free	
Switching frequency	f	100 Hz	
Mechanical data			
Enclosure material		PBT, black	
End cap		PA 12, transparent	
Ambient temperature		-25 °C ... +70 °C	
Protection class		IP67	
Display		LED, yellow	
Type of connection		Cable 2 x 0.5 mm ² ; PVC Coating, black	
Fastening aids		2 x hexagon nuts, PA 6.6, black	
EU Conformity			
according to directive 2014/30/EU (EMV-directive)			
EMV			
to EN 60947-5-2			
Remarks			
Overvoltage protection at 10-30 V for 400 ms.			

Cable couplings and other accessories can be found from p. 208



Electromechanical magnetic sensors

Standard range



Product features

- Metric types: M08/M12
- Special types: Ø 6 mm – Ø 15.5 mm, rectangular
- Sensing distance: 6 mm – 25 mm
- Switching function: NO contact, NC contact, Changeover contact, Bistable
- Enclosure material: aluminium, plastic, stainless steel, brass

Good to know ...

Magnetic sensors with reed contacts can be connected to both DC and AC voltage and do not consume power in passive operation.

Options

- Cable and connector assembly
- The enclosures can be adapted
- Product adaptations and modifications
- Customized development

Special features of electromechanical magnetic switches

- Perfect functioning under extreme environmental influences, such as dirt, moisture, gases, dust etc.
- Protection class up to IP67
- Stable switching point, reproducible switching point accuracy of approx. 0.1 mm
- Can be actuated from several directions
- Installation in any position
- High operational reliability is guaranteed by the standard use of only one component
- Easy installation
- Long electrical life (depending on the load to be switched), more than 10⁸ switching cycles with appropriate contact protection measures
- Special versions for extreme temperatures from -40 °C to +150 °C
- Can be connected to DC and AC voltage sources

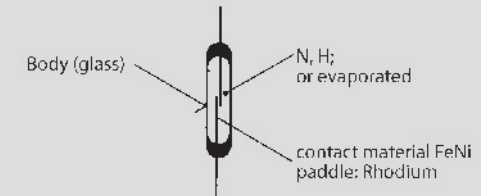

Design of a reed contact

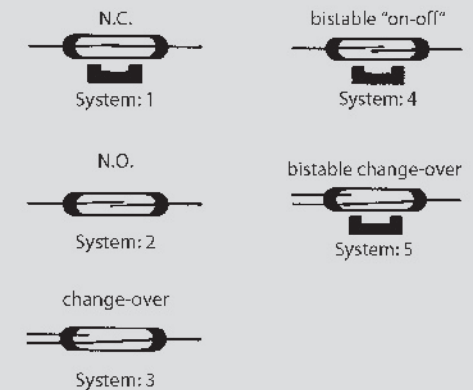

Types of reed contact switches

ELECTROMECHANICAL MAGNETIC SENSORS Type Ø 6 mm, Ø 6.5 mm, M8



Type	Ø 6 mm	Ø 6 mm	Ø 6.5 mm	M8
Enclosure material	PA, black	PA, black	PA, red	Stainless steel 1.4305
Nominal sensing distance (San)	29 mm	20 mm	20 mm	29 mm
Type of connection	Cable 1 m	Cable 1 m	Cable 2 m	Cable 1 m
Reference magnet	T-62 N/S	T-62 N/S	T-62 N/S	T-62 N/S
Special feature				
NO contact		6311230704 MAK-3012-F-1	6310246723 MAK-4612-F-2	
NC contact				
Changeover contact	6310330705 MAK-3013-D-1			6310308733 MAN-0813-D-1
bistable				
Technical data				
Switching voltage (max)	125 V AC / 175 V DC	250 V AC / DC	250 V AC / DC	125 V AC / 175 V DC
Switching current (max)	280 mA AC / 400 mA DC	1 A	1 A	280 mA AC / 400 mA DC
Max. switching capacity	5 VA	100 VA	100 VA	5 VA
Function/operating voltage indicator	-	-	-	-
Mechanical data				
Ambient temperature (min/max)	-5°C/+70°C	-5°C/+70°C	-5°C/+70°C	-5°C/+90°C
Protection class in accordance with IEC 529, EN 60529	IP67	IP67	IP67	IP67
Connection	3 x AWG 26	2 x AWG 26	2 x AWG 26	3 x AWG 26
Approval – observe the restricted electrical data in the data sheet				

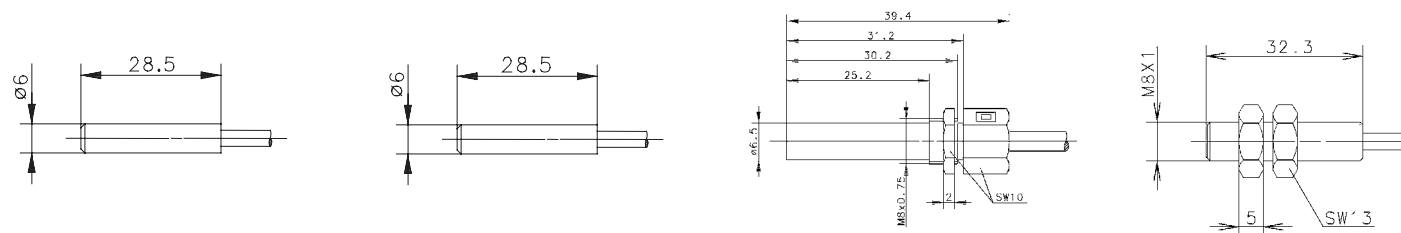

Cable couplings and other accessories can be found from p. 208



Type	M8	M8
Enclosure material	Stainless steel 1.4305	Stainless steel 1.4305
Nominal sensing distance (S _{an})	13 mm	20 mm
Type of connection	Cable 1 m	Cable 1 m
Reference magnet	T-62 N/S	T-62 N/S
Special feature		
NO contact		6311208732 MAN-0812-F-1
NC contact	6310108664 MAN-0811-Y-1	
Changeover contact		
bistable		
Technical data		
Switching voltage (max)	150 V AC / DC	250 V AC / DC
Switching current (max)	1 A	1 A
Max. switching capacity	20 VA	100 VA
Function/operating voltage indicator	-	-
Mechanical data		
Ambient temperature (min/max)	-5°C/+70°C	-5°C/+70°C
Protection class in accordance with IEC 529, EN 60529	IP67	IP67
Connection	2 x 0.34 mm ²	2 x AWG 26
Approval – observe the restricted electrical data in the data sheet		

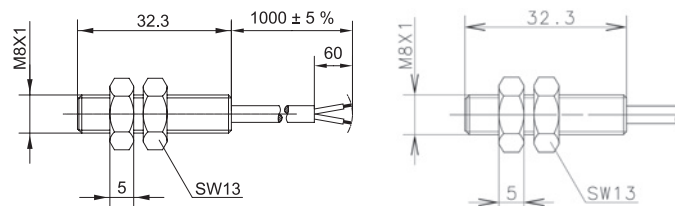

ELECTROMECHANICAL MAGNETIC SENSORS Type Ø 12 mm



Type	Ø 12 mm	Ø 12 mm	Ø 12 mm	Ø 12 mm
Enclosure material	Aluminium	Aluminium	Al / CuZn39Pb3	Al / CuZn39Pb3
Nominal sensing distance (San)	7 mm	20 mm	7 mm	8 mm
Type of connection	Cable 1 m	Cable 1 m	Cable 1 m	Cable 1 m
Reference magnet	T-62 N/S	T-62 N/S	T-62 N/S	T-62 N/S
Special feature				
NO contact	6312206678 MAA-0612-A-1		6314206246 MAA-0612-F-1	
NC contact				
Changeover contact				6315306314 MAA-0613-K-1
bistable		6310406685 MAA-0614-A-1		
Technical data				
Switching voltage (max)	250 V AC / DC	250 V AC / DC	250 V	250 V
Switching current (max)	3 A	3 A	3 A	0.5 A
Max. switching capacity	120 VA	120 VA	100 VA	30 VA
Function/operating voltage indicator	–	–	–	–
Mechanical data				
Ambient temperature (min/max)	–5°C/+70°C	–5°C/+70°C	–5°C/+70°C	–5°C/+70°C
Protection class in accordance with IEC 529, EN 60529	IP67	IP67	IP67	IP67
Connection	2 x AWG 20	2 x AWG 20	3 x 0.75 mm ²	4 x 0.75 mm ²
Approval – observe the restricted electrical data in the data sheet				

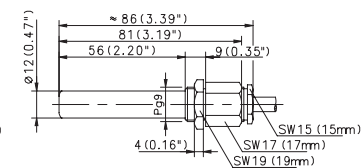
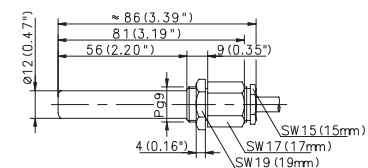
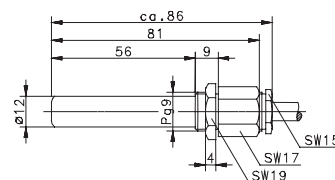
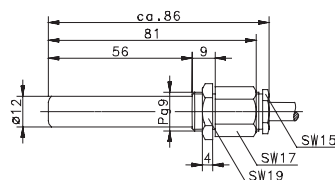

Cable couplings and other accessories can be found from p. 208



Type	Ø 12 mm	Ø 12 mm	Ø 12 mm	Ø 12 mm
Enclosure material	Al / CuZn39Pb3	Al / CuZn39Pb3	Al / CuZn39Pb3	Al / CuZn39Pb3
Nominal sensing distance (San)	16 mm	19 mm	19 mm	20 mm
Type of connection	Cable 4 m	Cable 1 m	Cable 1 m	Cable 4 m
Reference magnet	T-62 N/S	T-69 N/S	T-69 N/S	T-62 N/S
Special feature	Temperature		Temperature	
NO contact	6410206399 MAA-0612-NT-4			6310206680 MAA-0612-F-4
NC contact				
Changeover contact		6316306248 MAA-0613-L-1	6316306004 MAA-0613-LT-1	
bistable				
Technical data				
Switching voltage (max)	250 V AC / 200 V DC	250 V	250 V	250 V AC / DC
Switching current (max)	1.5 A	1 A	1 A	1 A
Max. switching capacity	50 VA	60 VA	60 VA	100 VA
Function/operating voltage indicator	-	-	-	-
Mechanical data				
Ambient temperature (min/max)	-40°C/+150°C	-5°C/+70°C	-40°C/+150°C	-5°C/+70°C
Protection class in accordance with IEC 529, EN 60529	IP67	IP67	IP67	IP67
Connection	3 x 0.75 mm ²	4 x 0.75 mm ²	4 x 0.75 mm ²	2 x AWG 20
Approval – observe the restricted electrical data in the data sheet				

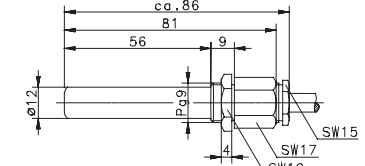
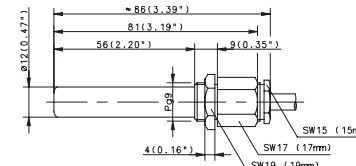
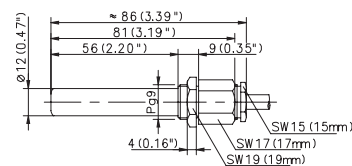
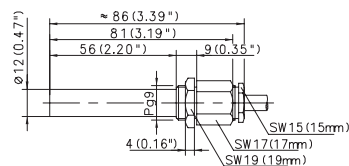

ELECTROMECHANICAL MAGNETIC SENSORS Type Ø 12 mm



Type	Ø 12 mm	Ø 12 mm	Ø 12 mm	Ø 12 mm
Enclosure material	Stainless steel 1.4305	Stainless steel 1.4305	Stainless steel 1.4305	Stainless steel 1.4305
Nominal sensing distance (San)	6 mm	7 mm	7 mm	12 mm
Type of connection	Cable 3 m	Cable 8 m	Cable 10 m	Cable 1 m
Reference magnet	T-62 N/S	T-62 N/S	T-62 N/S	T-62 N/S
Special feature		Temperature	Temperature	
NO contact	6314216734 MAN-1612-A-3	6314216585 MAN-1612-FT-8		
NC contact				
Changeover contact			6316316628 MAN-1613-LT-10	6316316259 MAN-1613-L-1
bistable				
Technical data				
Switching voltage (max)	250 V AC / DC	250 V	250 V	250 V
Switching current (max)	3 A	3 A	1 A	1 A
Max. switching capacity	120 VA	100 VA	60 VA	60 VA
Function/operating voltage indicator	–	–	–	–
Mechanical data				
Ambient temperature (min/max)	–5°C/+70°C	–40°C/+150°C	–40°C/+150°C	–5°C/+70°C
Protection class in accordance with IEC 529, EN 60529	IP67	IP67	IP67	IP67
Connection	2 x AWG 20	3 x 0.75 mm ²	4 x 0.75 mm ²	4 x 0.75 mm ²
Approval – observe the restricted electrical data in the data sheet				

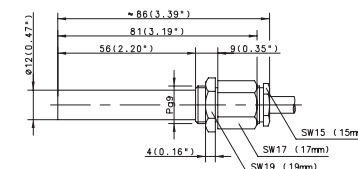
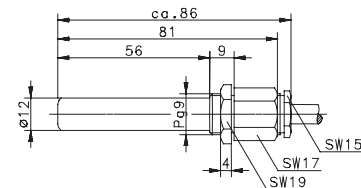
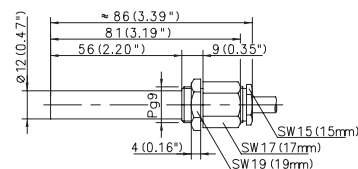
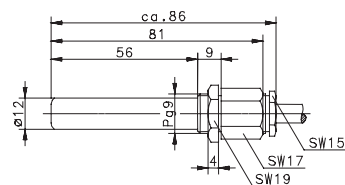

Cable couplings and other accessories can be found from p. 208



Type	Ø 12 mm	Ø 12 mm	Ø 12 mm	Ø 12 mm
Enclosure material	PA, red	PA, red	PA, red	PA, red
Nominal sensing distance (San)	7 mm	10 mm	16 mm	29 mm
Type of connection	Cable 1 m	Cable 1 m	Cable 2 m	Cable 1 m
Reference magnet	T-62 N/S	T-62 N/S	T-62 N/S	T-62 N/S
Special feature				
NO contact	6314226700			
	MAK-2612-A-1			
NC contact				
Changeover contact		6316326426		6315326701
		MAK-2613-L-1		MAK-2613-D-1
bistable			6420626354	
			MAK-2626-2	
Technical data				
Switching voltage (max)	250 V AC / DC	250 V	30 V AC / DC	125 V AC / 175 V DC
Switching current (max)	3 A	1 A	0.25 A	280 mA AC / 400 mA DC
Max. switching capacity	120 VA	60 VA	5 VA	5 VA
Function/operating voltage indicator	–	–	–	–
Mechanical data				
Ambient temperature (min/max)	–5°C/+70°C	–5°C/+70°C	–5°C/+70°C	–5°C/+70°C
Protection class in accordance with IEC 529, EN 60529	IP67	IP67	IP67	IP67
Connection	2 x AWG 20	3 x 0.5 mm ²	4 x 0.25 mm ²	3 x AWG 20
Approval – observe the restricted electrical data in the data sheet				

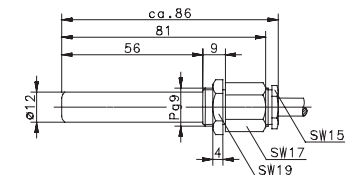
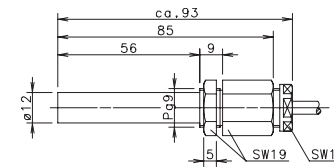
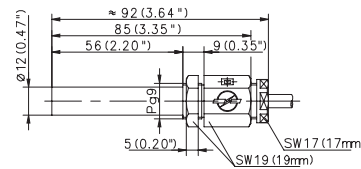
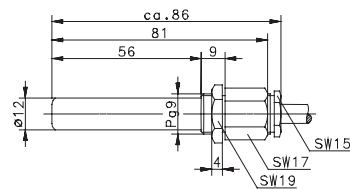

ELECTROMECHANICAL MAGNETIC SENSORS Type M12



Type	M12	M12	M12	M12
Enclosure material	CuZn39Pb3	CuZn39Pb3	CuZn39Pb3	CuZn39Pb3
Nominal sensing distance (San)	6 mm	18 mm	20 mm	29 mm
Type of connection	Cable 1 m	Cable 6 m	Cable 1 m	Cable 6 m
Reference magnet	T-62 N/S	T-62 N/S	T-62 N/S	T-62 N/S
Special feature				
NO contact	6314223730 MAK-2312-A-1		6311218728 MAM-1812-F-1	
NC contact		6420218189 MAM-1822-6		6310118727 MAM-1811-D-2
Changeover contact				
1 NO contact / 1 NC contact				
Technical data				
Switching voltage (max)	250 V AC / DC	60 V	250 V AC / DC	125 V AC / 175 V DC
Switching current (max)	3 A	0.5 A	1 A	280 mA AC / 400 mA DC
Max. switching capacity	120 VA	10 VA	100 VA	5 VA
Function/operating voltage indicator	–	–	–	–
Mechanical data				
Ambient temperature (min/max)	–5°C/+70°C	–5°C/+70°C	–5°C/+70°C	–5°C/+70°C
Protection class in accordance with IEC 529, EN 60529	IP67	IP67	IP67	IP67
Connection	2 x AWG 20	4 x 0.25 mm ²	2 x AWG 20	2 x AWG 20
Approval – observe the restricted electrical data in the data sheet				

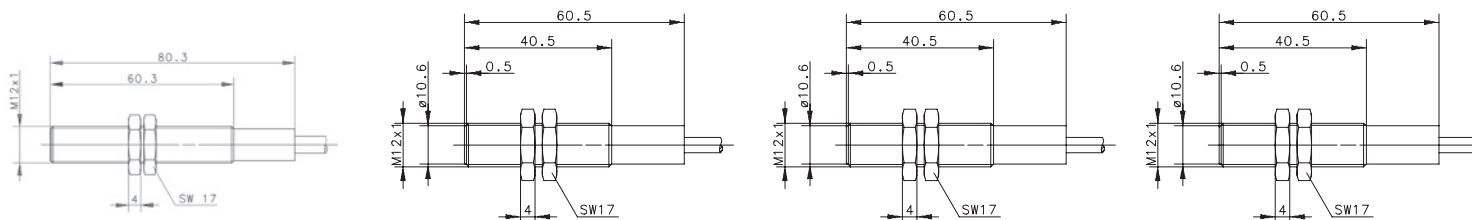

Cable couplings and other accessories can be found from p. 208



Type	M12	M12	M12	M12
Enclosure material	PA, red	PA, red	PA, red	PBT, black
Nominal sensing distance (San)	7 mm	22 mm	29 mm	29 mm
Type of connection	Cable 2 m	Cable 2 m	Cable 3 m	Cable 2 m
Reference magnet	T-62 N/S	T-62 N/S	T-62 N/S	T-62 N/S
Special feature				
NO contact	6314233708 MAK-3312-A-2		6316228703 MAK-2812-D-3	6410299498 MAK-9912-2
NC contact				
Changeover contact				
bistable		6310433710 MAK-3314-A-2		
Technical data				
Switching voltage (max)	250 V AC / DC	250 V AC / DC	125 V AC / 175 V DC	200 V
Switching current (max)	3 A	3 A	280 mA AC / 400 mA DC	0.5 A
Max. switching capacity	120 VA	120 VA	5 VA	10 VA
Function/operating voltage indicator	–	–	–	–
Mechanical data				
Ambient temperature (min/max)	–5°C/+70°C	–5°C/+70°C	–5°C/+70°C	–5°C/+70°C
Protection class in accordance with IEC 529, EN 60529	IP67	IP67	IP67	IP67
Connection	2 x AWG 20	2 x AWG 20	2 x AWG 20	2 x 0.5 mm ²
Approval – observe the restricted electrical data in the data sheet				

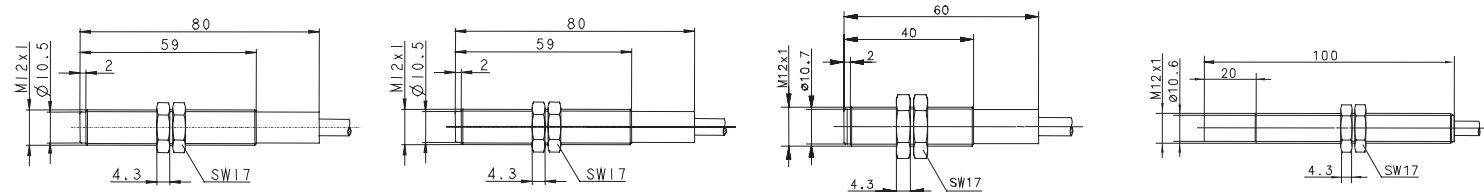

ELECTROMECHANICAL MAGNETIC SENSORS Type PG9



Type	PG9	PG9	PG9
Enclosure material	CuZn39Pb3	CuZn39Pb3	PA, red
Nominal sensing distance (San)	20 mm	29 mm	11 mm
Type of connection	Cable 2 m	Cable 2 m	Cable 3 m
Reference magnet	T-62 N/S	T-62 N/S	T-62 N/S
Special feature			

NO contact

NC contact

Changeover contact

6316343731
MAM-4313-D-2

6415317431
MAK-1713-K-3

bistable **6310431569**
MAM-3114-2-LED

Technical data

Switching voltage (max)	250 V	125 V AC / 175 V DC	250 V
Switching current (max)	1 A	280 mA AC / 400 mA DC	0,5 A
Max. switching capacity	120 VA	5 VA	30 VA
Function/operating voltage indicator	LED	-	-

Mechanical data

Ambient temperature (min/max)	-5°C/+80°C	-5°C/+70°C	-5°C/+70°C
Protection class in accordance with IEC 529, EN 60529	IP65	IP67	IP67
Connection	2 x 0.5 mm ²	3 x AWG 20	3 x 0.5 mm ²

Approval – observe the restricted electrical data in the data sheet

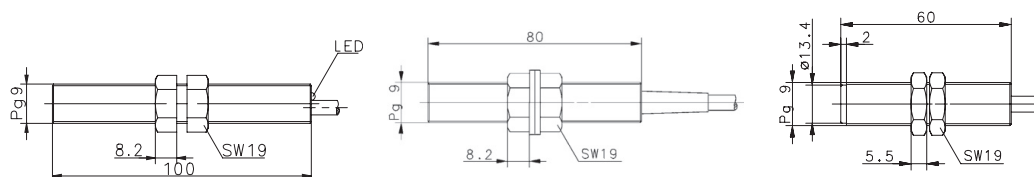

Cable couplings and other accessories can be found from p. 208

ELECTROMECHANICAL MAGNETIC SENSORS Type Ø 13 mm, 28.6x18x6.4 mm



Type	Ø 13 mm	Ø 13 mm	28.6 x 18 x 6.4 mm	28.6 x 18 x 6.4 mm
Enclosure material	PA, black	PA, black	PA, black	PA, black
Nominal sensing distance (San)	9 mm	20 mm	8 mm	8 mm
Type of connection	Cable 1 m	Cable 1 m	Cable 1.5 m	Cable 10 m
Reference magnet	T-62 N/S	T-62 N/S	TK-11-11	TK-11-11
Special feature				

NO contact

NC contact	6310136711 MAK-3611-A-1		631111665 MAK-1111-10
-------------------	-----------------------------------	--	---------------------------------

Changeover contact

bistable	6310536617 MAK-3615-L-1	641031368 MAK-1113-1,5
-----------------	-----------------------------------	----------------------------------

Technical data				
Switching voltage (max)	250 V DC / AC	250 V	130 V	130 V AC, 175 V DC
Switching current (max)	3 A	1 A	0,25 A	0.25 A
Max. switching capacity	120 VA	60 VA	3 VA	5 VA
Function/operating voltage indicator	-	-	-	-

Mechanical data				
Ambient temperature (min/max)	-5°C/+70°C	-5°C/+70°C	-20°C/+70°C	-5°C/+70°C
Protection class in accordance with IEC 529, EN 60529	IP67	IP67	IP67	IP67
Connection	2 x AWG 20	3 x 0.75 mm ²	3 x 0.14 mm ²	2 x 0.14 mm ²

Approval – observe the restricted electrical data in the data sheet

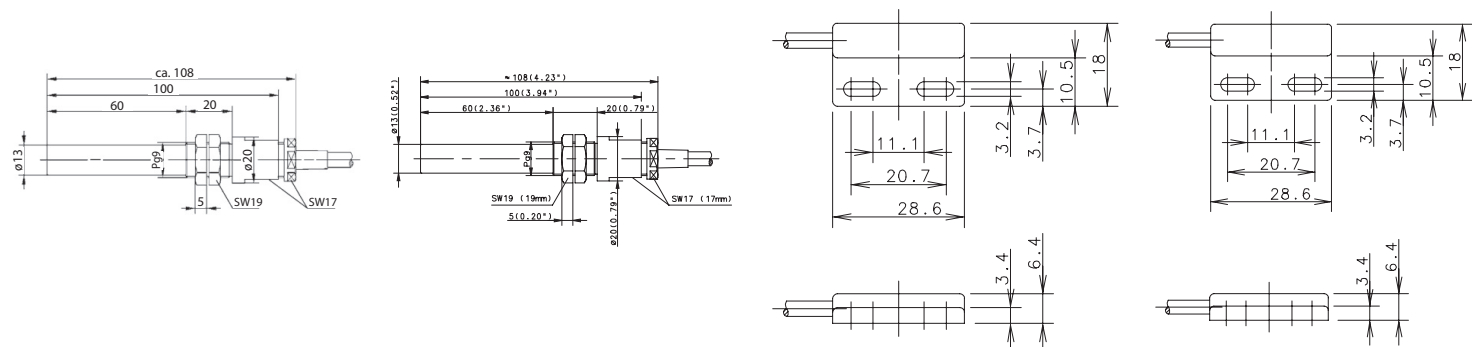

You can find detailed product data sheets at www.bernstein.eu

ELECTROMECHANICAL MAGNETIC SENSORS Type 28.6x18x6.4 mm



Type	28.6 x 18 x 6.4 mm	28.6 x 18 x 6.4 mm	28.6 x 18 x 6.4 mm
Enclosure material	PA, black	PA, black	PA, black
Nominal sensing distance (San)	10 mm	12 mm	30 mm
Type of connection	Cable 1 m	Cable 1 m	Cable 5 m
Reference magnet	TK-11-11	TK-11-11	T-67 N/S
Special feature			
NO contact	6311211692 MAK-1112-F-1		
NC contact			
Changeover contact		6310311693 MAK-1113-D-1	
bistable			6311411603 MAK-1114-B-5
Technical data			
Switching voltage (max)	250 V AC / DC	125 V AC / 175 V DC	250 V
Switching current (max)	1 A	280 mA AC / 400 mA DC	0.5 A
Max. switching capacity	100 VA	5 VA	10 VA
Function/operating voltage indicator	-	-	-
Mechanical data			
Ambient temperature (min/max)	-5°C/+70°C	-5°C/+70°C	-5°C/+70°C
Protection class in accordance with IEC 529, EN 60529	IP67	IP67	IP67
Connection	2 x AWG 26	3 x AWG 26	2 x 0.14 mm ²
Approval – observe the restricted electrical data in the data sheet			

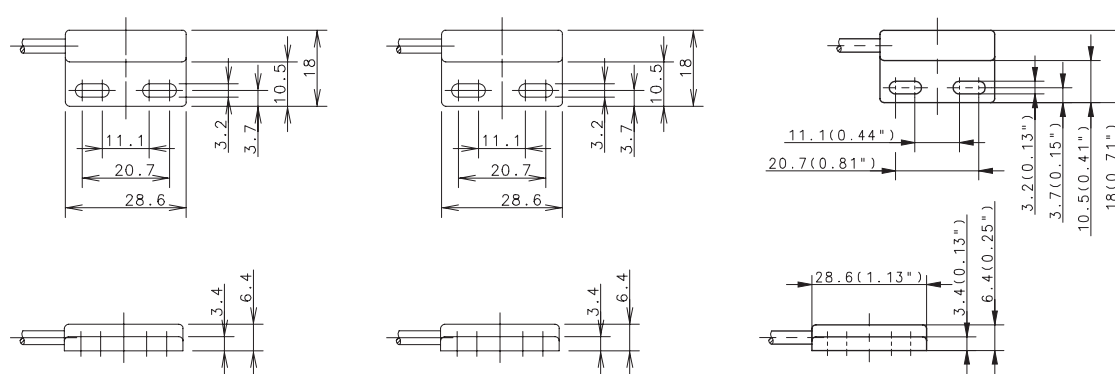

Cable couplings and other accessories can be found from p. 208

ELECTROMECHANICAL MAGNETIC SENSORS Type 45 x 13 x 9 mm, 45 x 25.5 x 9 mm



Type	45 x 13 x 9 mm	45 x 25.5 x 9 mm
Enclosure material	PA, black	PA, black
Nominal sensing distance (San)	10 mm	12 mm
Type of connection	Cable 3 m	Cable 1 m
Reference magnet	TK-11-01	TK-45
Special feature		

NO contact

NC contact

Changeover contact	6310301666 MAK-0113-3	6316345722 MAK-4513-D-1
--------------------	---------------------------------	-----------------------------------

bistable

Technical data		
Switching voltage (max)	175 V	125 V AC / 175 V DC
Switching current (max)	0.25 A	280 mA AC / 400 mA DC
Max. switching power	10 VA	5 VA
Function/operating voltage indicator	-	-

Mechanical data		
Ambient temperature (min/max)	-5°C/+70°C	-5°C/+70°C
Protection class in accordance with IEC 529, EN 60529	IP67	IP67
Connection	3 x 0.14 mm ²	3 x AWG 26

Approval – observe the restricted electrical data in the data sheet

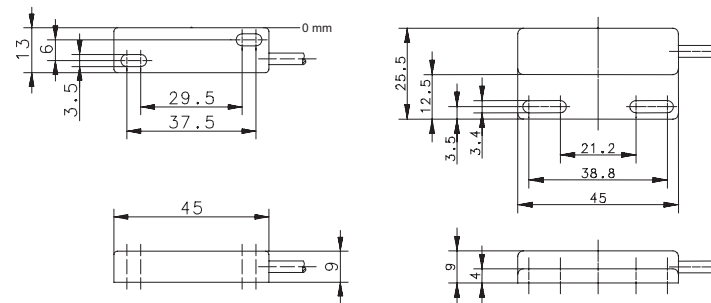

ELECTROMECHANICAL MAGNETIC SENSORS Type 80x20x15 mm



Type	80 x 20 x 15 mm	80 x 20 x 15 mm	80 x 20 x 15 mm	80 x 20 x 15 mm
Enclosure material	GDAISi12, red	GDAISi12, red	GDAISi12, red	GDAISi12, red
Nominal sensing distance (San)	5-40 mm	20 mm	25 mm	30 mm
Type of connection	Cable 3 m	Cable 3 m	Connector M8	Cable 1 m
Reference magnet	TK-21-02	T-62 N/S	TA-21-02	TA-21-02
Special feature		Temperature		Temperature
NO contact	6314402674 MAA-0214-A-3			
NC contact				
Changeover contact			6310302636 MAA-0213-STK	6316302389 MAA-0213-LT-1
bistable		6314402566 MAA-0214-FT-3		
Technical data				
Switching voltage (max)	250 V AC / DC	250 V	50 V AC / 75 V DC	250 V
Switching current (max)	3 A	3 A	1 A	1 A
Max. switching power	120 VA	100 VA	3 VA	60 VA
Function/operating voltage indicator	-	-	-	-
Mechanical data				
Ambient temperature (min/max)	-10°C/+80°C	-40°C/+150°C	-30°C/+80°C	-40°C/+150°C
Protection class in accordance with IEC 529, EN 60529	IP67	IP67	IP65	IP67
Connection	2 x AWG 20	3 x 0.75 mm ²	M8 x 1	4 x 0.75 mm ²
Approval – observe the restricted electrical data in the data sheet				

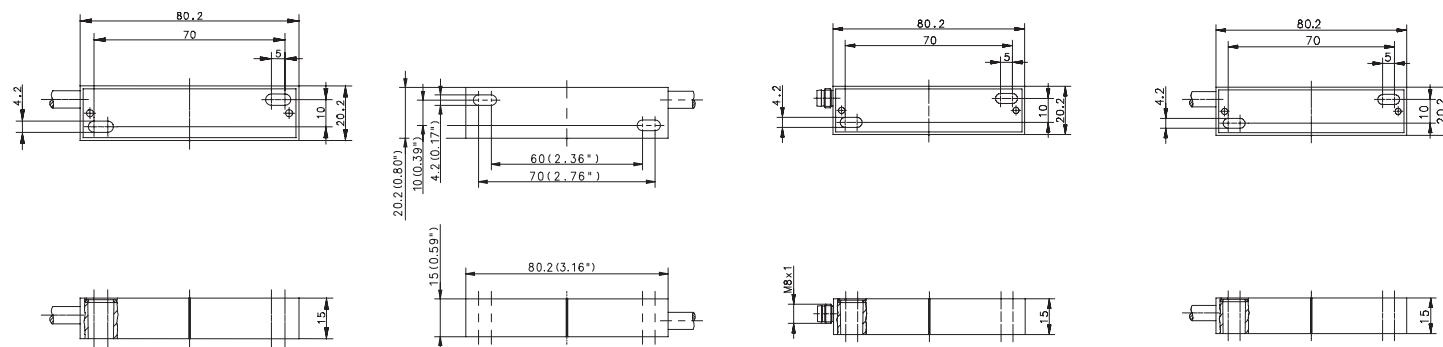

Cable couplings and other accessories can be found from p. 208



Type	80 x 20 x 15 mm	80 x 20 x 15 mm	80 x 20 x 15 mm	80 x 20 x 15 mm
Enclosure material	PA, black	PA, black	PA, red	PA, red
Nominal sensing distance (San)	10 mm	18 mm	18 mm	18 mm
Type of connection	Cable 3 m	Con. cable 0.9 m with plug connector	Cable 1 m	Cable 2 m
Reference magnet	T-67 N/S	TK-21-02	TK-21-02	T-62 N/S
Special feature		Temperature		
NO contact		642022219 MAK-0222-L-0,8-STK		
NC contact				
Changeover contact			6315312696 MAK-1213-D-1	
bistable	6319402691 MAK-0214-A-3			6310412698 MAK-1214-A-2
Technische Daten				
Switching voltage (max)	250 V AC / DC	250 V	125 V AC / 175 V DC	250 V AC / DC
Switching current (max)	3 A	1 A	280 mA AC / 400 mA DC	3 A
Max. switching power	120 VA	60 VA	5 VA	120 VA
Function/operating voltage indicator	-	-	-	-
Mechanical data				
Ambient temperature (min/max)	-5°C/+70°C	-30°C/+70°C	-5°C/+70°C	-5°C/+70°C
Protection class in accordance with IEC 529, EN 60529	IP67	IP65	IP67	IP67
Connection	2 x AWG 20	Connection cable with plug connector	3 x 1.5 mm ²	2 x AWG 20
Approval – observe the restricted electrical data in the data sheet				

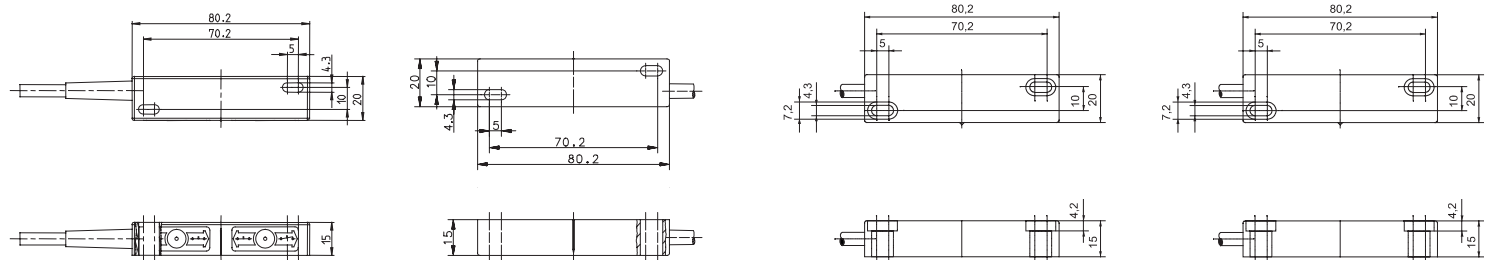

ELECTROMECHANICAL MAGNETIC SENSORS Type 80x20x15 mm



Type	80 x 20 x 15 mm	80 x 20 x 15 mm	80 x 20 x 15 mm	80 x 20 x 15 mm
Enclosure material	PC, black	PA, black	PA, black	PA, red
Nominal sensing distance (San)	18 mm	21 mm	21 mm	21 mm
Type of connection	Cable 1 m	Cable 1 m	Cable 1 m	Cable 1 m
Reference magnet	TK-21-02	TK-21-02	TK-21-02	TK-21-12
Special feature				
NO contact		6312202687 MAK-0212-A-1	6314202204 MAK-0212-F-1	6314212695 MAK-1212-A-1
NC contact				
Changeover contact	6315302689 MAK-0213-D-1			
bistable				
Technical data				
Switching voltage (max)	125 V AC / 175 V DC	250 V AC / DC	250 V	250 V AC / DC
Switching current (max)	280 mA AC / 400 mA DC	3 A	3 A	3 A
Max. switching power	5 VA	120 VA	100 VA	120 VA
Function/operating voltage indicator	-	-	-	-
Mechanical data				
Ambient temperature (min/max)	-5°C/+70°C	-5°C/+70°C	-5°C/+70°C	-5°C/+70°C
Protection class in accordance with IEC 529, EN 60529	IP67	IP67	IP67	IP67
Connection	3 x AWG 20	2 x AWG 20	2 x 0.75 mm ²	2 x AWG 20
Approval – observe the restricted electrical data in the data sheet				

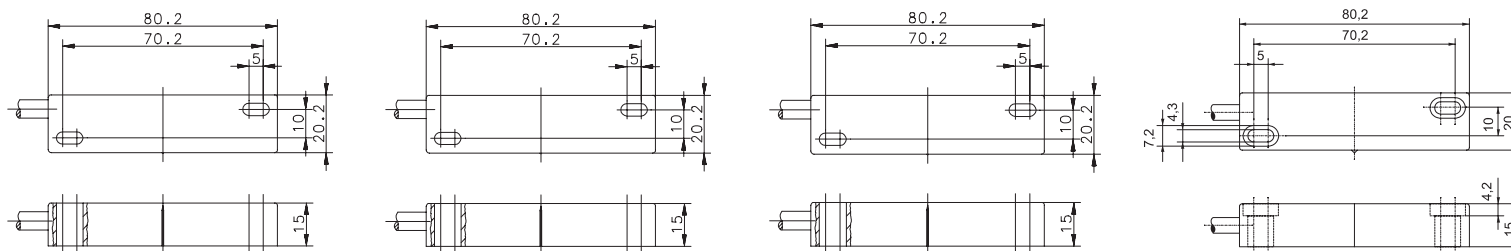

Cable couplings and other accessories can be found from p. 208



Type	80 x 20 x 15 mm	80 x 20 x 15 mm
Enclosure material	PA, black	PA, red
Nominal sensing distance (San)	24 mm	24 mm
Type of connection	Cable 1 m	Cable 1 m
Reference magnet	TA-21-02	TK-21-12
Special feature		

NO contact

NC contact

Changeover contact	6316302206 MAK-0213-L-1	6316312220 MAK-1213-L-1
---------------------------	-----------------------------------	-----------------------------------

bistable

Technical data		
Switching voltage (max)	250 V	250 V
Switching current (max)	1 A	1 A
Max. switching power	60 VA	60 VA
Function/operating voltage indicator	-	-

Mechanical data		
Ambient temperature (min/max)	-5°C/+70°C	-5°C/+70°C
Protection class in accordance with IEC 529, EN 60529	IP67	IP67
Connection	3 x 0.5 mm ²	3 x 0.5 mm ²

Approval – observe the restricted electrical data in the data sheet

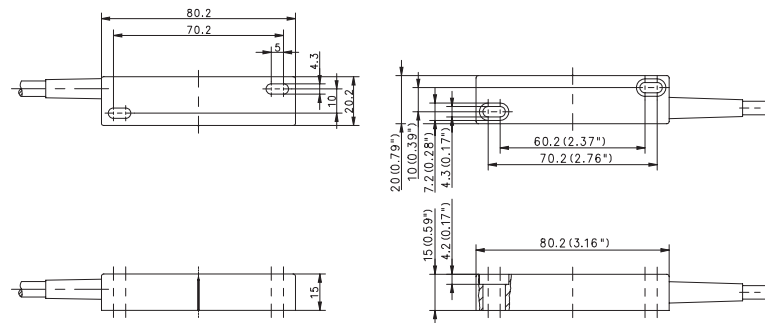

ELECTROMECHANICAL MAGNETIC SENSORS Type 80x30x15 mm



Type	80 x 30 x 15 mm	80 x 30 x 15 mm	80 x 30 x 15 mm	80 x 30 x 15 mm
Enclosure material	PA, black	PA, black	PA, black	PA, black
Nominal sensing distance (San)	8 mm	18 mm	7-23 mm	19 mm
Type of connection	Cable 1 m	Cable 1 m	Cable 2 m	Cable 1 m
Reference magnet	TK-44	T-62 N/S	T-62 N/S	TK-44
Special feature				
NO contact				6314244718 MAK-4412-A-1
NC contact	6314144717 MAK-4411-A-1			
Changeover contact				
bistable		6310444720 MAK-4414-A-1		
Bistable Changeover contact			6316544621 MAK-4415-L-2	
Technical data				
Switching voltage (max)	250 V AC / DC	250 V AC / DC	250 V	250 V AC / DC
Switching current (max)	3 A	3 A	1 A	3 A
Max. switching power	120 VA	120 VA	60 VA	120 VA
Function/operating voltage indicator	-	-	-	-
Mechanical data				
Ambient temperature (min/max)	-5°C/+70°C	-5°C/+60°C	-5°C/+70°C	-5°C/+70°C
Protection class in accordance with IEC 529, EN 60529	IP67	IP67	IP67	IP67
Connection	2 x AWG 20	2 x AWG 20	3 x 0.5 mm ²	2 x AWG 20
Approval – observe the restricted electrical data in the data sheet				

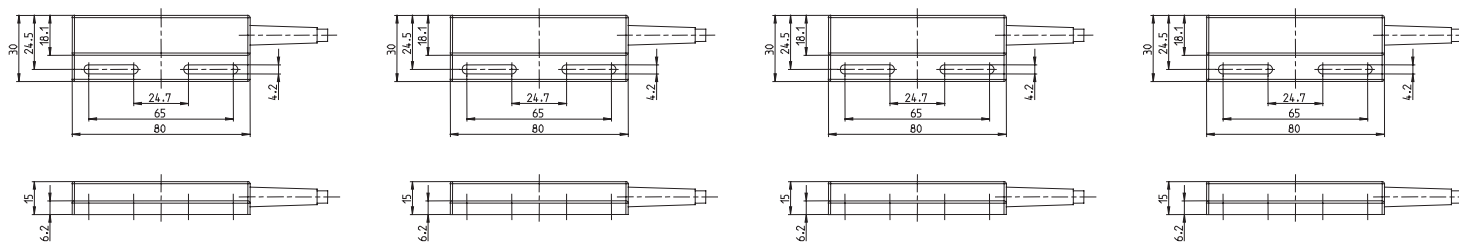

Cable couplings and other accessories can be found from p. 208

ELECTROMECHANICAL MAGNETIC SENSORS Type 80x30x15 mm, 85x24x26 mm



Type	80 x 30 x 15 mm	85 x 24 x 26 mm	85 x 24 x 26 mm	85 x 24 x 26 mm
Enclosure material	PA, black	PBT, black	PBT, black	PBT, black
Nominal sensing distance (San)	22 mm	2-15 mm	17 mm	24 mm
Type of connection	Cable 1 m	Cable 3 m	Cable 1 m	Flat plug
Reference magnet	TK-44	T-67 N/S	T-62 N/S	T-69 N/S
Special feature				Flat plug K4.8

NO contact

NC contact

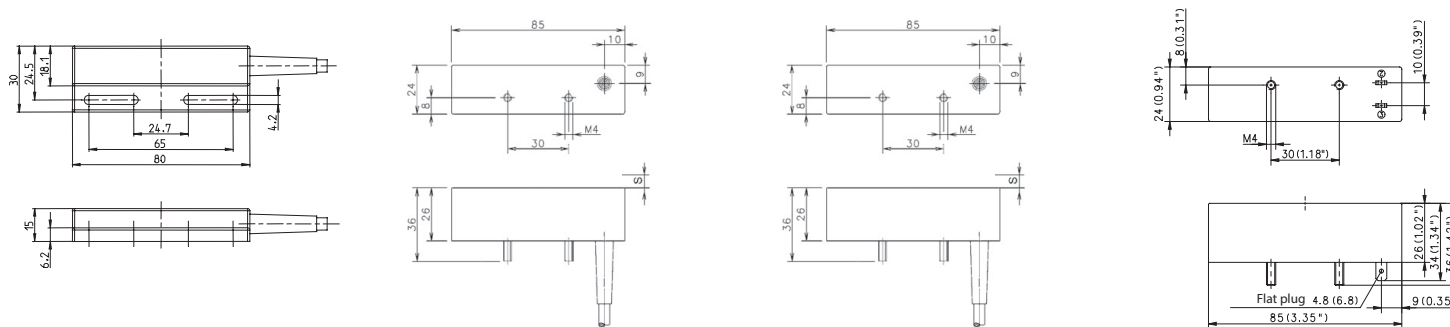

Changeover contact	6317344719 MAK-4413-D-1			
bistable		6314432706 MAK-3214-A-3	6310432707 MAK-3214-A-1	6310432590 MAK-3214-P-STK4.8
Technical data				
Switching voltage (max)	125 V AC / 175 V DC	250 V AC / DC	250 V	250 V
Switching current (max)	280 mA AC / 400 mA DC	3 A	3 A	5 A
Max. switching power	5 VA	120 VA	120 VA	250 VA
Function/operating voltage indicator	-	-	-	-
Mechanical data				
Ambient temperature (min/max)	-5°C/+70°C	-5°C/+70°C	-5°C/+70°C	-20°C/+70°C
Protection class in accordance with IEC 529, EN 60529	IP67	IP67	IP67	IP67
Connection	3 x AWG 20	2 x AWG 20	2 x AWG 20	Flat plug 4.8
Approval – observe the restricted electrical data in the data sheet				



You can find detailed product data sheets at www.bernstein.eu

ELECTROMECHANICAL MAGNETIC SENSORS Type 88x25x13 mm



Type	88 x 25 x 13 mm	88 x 25 x 13 mm	88 x 25 x 13 mm	88 x 25 x 13 mm
Enclosure material	PA, black	PA, black	PA, black	PA, black
Nominal sensing distance (San)	18 mm	19 mm	2-20 mm	22 mm
Type of connection	Cable 5 m	Cable 1 m	Cable 1 m	Cable 1 m
Reference magnet	T-62 N/S	TK-42	T-62 N/S	TK-42
Special feature	2 NO contacts			
NO contact	6420242220 MAK-4222-5	6314242713 MAK-4212-A-1		
NC contact				
Changeover contact				6317342714 MAK-4213-D-1
bistable			6310442715 MAK-4214-A-1	
Technical data				
Switching voltage (max)	230 V	30 V AC / 60 V DC	250 V AC / DC	125 V AC / 175 V DC
Switching current (max)	3 A	2 A	3 A	280 mA AC / 400 mA DC
Max. switching power	100 VA	100 VA	120 VA	5 VA
Function/operating voltage indicator	-	-	-	-
Mechanical data				
Ambient temperature (min/max)	-5°C/+70°C	-5°C/+70°C	-5°C/+70°C	-5°C/+70°C
Protection class in accordance with IEC 529, EN 60529	IP67	IP67	IP67	IP67
Connection	4 x 0.5 mm ²	2 x AWG 20	2 x AWG 20	3 x AWG 20
Approval – observe the restricted electrical data in the data sheet				

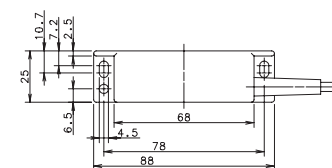
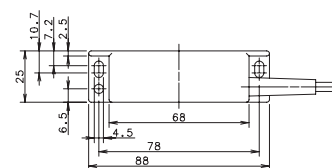
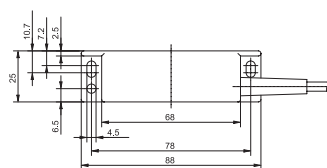
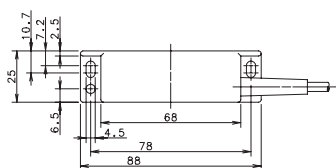

Cable couplings and other accessories can be found from p. 208

ELECTROMECHANICAL MAGNETIC SENSORS Type 100x58x29.5 mm



Type	100 x 58 x 29.5 mm	100 x 58 x 29.5 mm	100 x 58 x 29.5 mm
Enclosure material	Aluminium	Aluminium	GDAISI12
Nominal sensing distance (San)	10 mm	20 mm	15 mm
Type of connection	Screw terminal	Screw terminal	Screw terminal
Reference magnet	TA-31	TA-31	T-62 N/S
Special feature			
NO contact		6314203675 MAA-0312-A	
NC contact			
Changeover contact	6317303312 MAA-0313-M		
bistable			6319403677 MAA-0314-A
Technical data			
Switching voltage (max)	250 V DC / AC	250 V DC / AC	250 V DC / AC
Switching current (max)	1 A	3 A	3 A
Max. switching power	80 VA	120 VA	120 VA
Function/operating voltage indicator	-	-	-
Mechanical data			
Ambient temperature (min/max)	-5°C/+70°C	-15°C/+70°C	-15°C/+70°C
Protection class in accordance with IEC 529, EN 60529	IP67	IP65	IP65
Connection	Screw terminal	Screw terminal	Screw terminal

Approval – observe the restricted electrical data in the data sheet

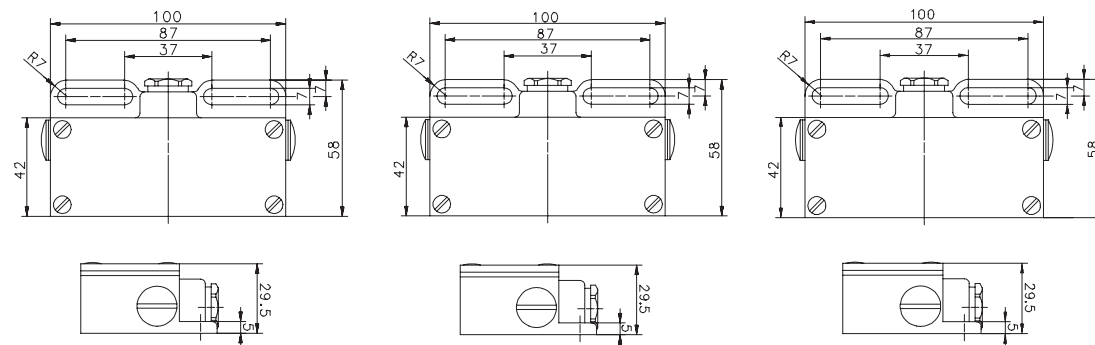

Electronic Magnetic Sensors

Standard range



Product features

- Metric types: M05 – M18
- Special types: Ø 4 mm/Ø 6 mm, rectangular
- Sensing distance: 2 mm – 45 mm
- Switching function: NO contact, NC contact, Bistable
- Enclosure material: Stainless steel, brass, plastic

Good to know ...

BERNSTEIN offers electronic speed sensors. These detect ferromagnetic gears with a switching frequency of up to 20kHz and do not require an actuating magnet.

Options

- Cable and connector assembly
- The enclosures can be adapted
- Product adaptations and modifications
- Customized development

Electronic magnetic switches with magnetoresistive or Hall elements are ideal for use in different applications due to their special properties. They are insensitive to shock, impact, vibration and wear. High switching frequencies, large switching distances, a wide temperature range and very good reproducibility are also among the advantages of this technology.

Advantages of electronic magnetic sensors over electromechanical reed contacts are:

- Reliable and insensitive to vibrations
- Bounce-free switching
- Unlimited life
- High repetition accuracy
- Fast response times
- High sensitivity
- Temperature stability

Standard programme magnetoresistive

Magnetoresistive sensors are about 10 times more sensitive than sensors with the Hall effect. They can not only be very small, but they can also detect particularly low field strengths.

At the same time, they are characterised by a high measuring accuracy - even at high ambient temperatures - a special reliability and a small space requirement. In addition, they are in principle, polarity independent, so that the counter magnet does not have to be mounted pole-oriented.

Magnet	Dimensions	Article number	Sn for Hall sensors	Sn for magnetoresistive sensors
T 06	Ø 6 mm	6301106065	5 mm	15 mm
T 61	Ø 20 mm	6301261035	10 mm	35 mm
T 62	Ø 23 mm	6301262039	17 mm	45 mm
T 67	Ø 20 mm	6301167054	15 mm	40 mm
T 69	Ø 31 mm	6301269031	20 mm	60 mm

ELECTRONIC MAGNETIC SENSORS Type D06, M08, M10



Type		D06	M08	M10	M10
Enclosure material		Stainless steel 1.4401	CuZn39Pb3	CuZn39Pb3	CuZn39Pb3
Operating mode		MR	MR	Hall	Hall
Magnetic sensitivity (mT)		1.5 mT	1.5 mT	10 mT	10 mT
Sensing distance (Sn)		45 mm	45 mm	17 mm	17 mm
Reference magnet (Side)		T-62 N/S	T-62 N/S	T-62 N/S	T-62 N/S
Type of connection		Cable 2 m	Cable 2 m	Cable 2 m	Cable 2 m
Special feature				All-metal	Temperature
PNP	NO contact	6373270105 MEN-D06PS/M02-K2	6373260107 MEM-M08PS/M02-K2	6372261085 MEM-M10PS/H10-KL2	6472261080 MEM-M10PS/H10-KL2T
NPN	NO contact				
NPN	bistable				
Technical data					
Rated operating voltage range	U_B	10–30 VDC	10–30 V	10–39 V	10–39 V
Rated operating current	I_e	200 mA	200 mA	400 mA	400 mA
Max. switching voltage	F	1500 Hz	1500 Hz	10 kHz	1500 Hz
Function/operating voltage indicator		–/–	–/–	LED/–	LED/–
Sensitivity adjustable					
Short circuit-protection		cyclic	cyclic	cyclic	cyclic
Mechanical data					
Ambient temperature (min/max)		–25°C/+70°C	–25°C/+70°C	–25°C/+70°C	–40°C/+70°C
Protection class in accordance with IEC 529, EN 60529		IP67	IP67	IP67	IP67
Connection		3 x 0.14 mm ²	3 x 0.14 mm ²	3 x 0.14 mm ²	3 x 0.14 mm ²

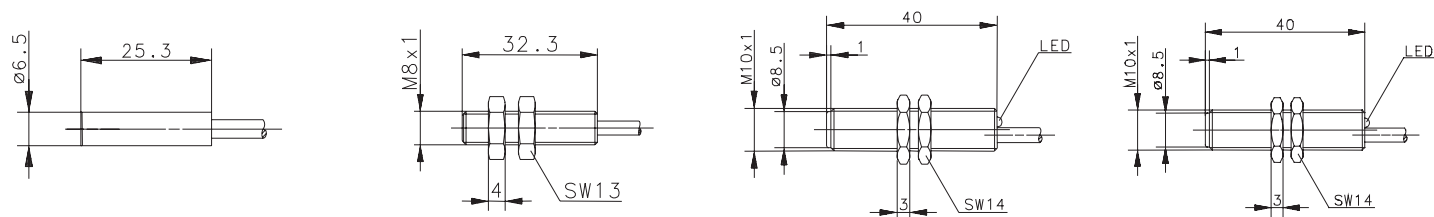

Cable couplings and other accessories can be found from p. 208

ELECTRONIC MAGNETIC SENSORS Type M12



Type	M12	M12	M12	M12
Enclosure material	CuZn39Pb3	CuZn39Pb3	CuZn39Pb3	CuZn39Pb3
Operating mode	Hall	Hall	MR	Hall
Magnetic sensitivity (mT)	10 mT	10 mT	1 mT	-
Sensing distance (Sn)	17 mm	17 mm	45 mm	0-2 mm
Reference magnet (Side)	T-62 N/S	T-62 N/S	T-62 N/S	-
Type of connection	Cable 2 m	Connector M12 x 1	Cable 5 m	Cable 2 m
Special feature				Speed sensor
PNP	NO contact	6372262090 MEM-M12PS/H10-KL2	6372262160 MEM-M12PS/H10-KLS12	6379262120 MEM-M12PD/H-KL2
NPN	NO contact			
NPN	bistable			
Technical data				
Rated operating voltage range	U_B	10–39 VDC	10–39 VDC	10–39 VDC
Rated operating current	I_e	400 mA	400 mA	400 mA
Max. switching voltage	F	10 kHz	10 kHz	1500 Hz
Function/operating voltage indicator		LED/-	LED/-	LED/-
Sensitivity adjustable				
Short circuit-protection		cyclic	cyclic	cyclic
Mechanical data				
Ambient temperature (min/max)		-25°C/+70°C	-25°C/+70°C	-25°C/+70°C
Protection class in accordance with IEC 529, EN 60529		IP67	IP67	IP67
Connection		3 x 0.14 mm ²	M12 x 1	3 x 0.14 mm ²

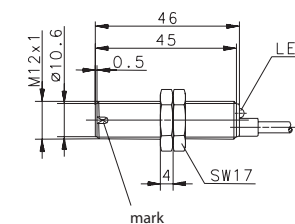
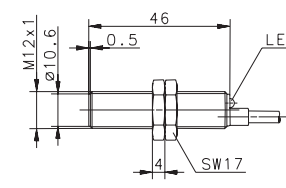
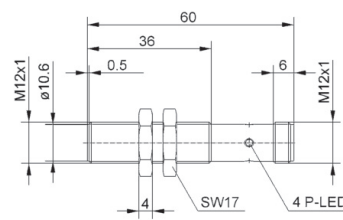
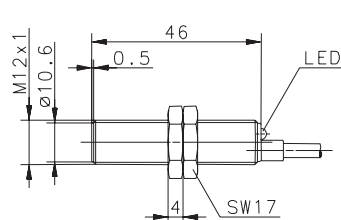

ELECTRONIC MAGNETIC SENSORS Type M12, M18



Type	M12	M18	M18	M18
Enclosure material	PA, red	CuZn39Pb3	PBT, black	PBT, black
Operating mode	Hall	MR	MR	Hall
Magnetic sensitivity (mT)	–	1 mT	1 mT	–
Sensing distance (Sn)	0-2 mm	45 mm	45 mm	0 – 2 mm
Reference magnet (Side)	–	T-62 N/S	T-62 N/S	–
Type of connection	Cable 2 m	Cable 2 m	Cable 2 m	Cable 2 m
Special feature	Speed sensor			Speed sensor
PNP	NO contact	6373263102	6373263101	6379263121
		MEM-M18PS/M01-KL2	MEK-M18PS/M01-KL2	MEK-M18PD/H-KL2
PNP	NC contact	6379262119		
		MEK-M12PD/H-KL2		
PNP	bistable			
Technical data				
Rated operating voltage range	U_B	10–39 VDC	10–39 VDC	10–39 VDC
Rated operating current	I_e	400 mA	400 mA	400 mA
Max. switching voltage	F	10 kHz	10 kHz	10 kHz
Function/operating voltage indicator		LED/–	LED/–	LED/–
Sensitivity adjustable				
Short circuit-protection		cyclic	cyclic	cyclic
Mechanical data				
Ambient temperature (min/max)		–25°C/+70°C	–25°C/+70°C	–25°C/+70°C
Protection class in accordance with IEC 529, EN 60529		IP67	IP67	IP67
Connection		3 x 0.14 mm ²	3 x 0.14 mm ²	3 x 0.14 mm ²

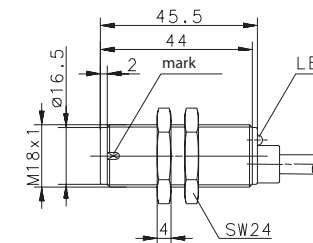
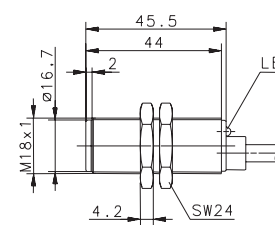
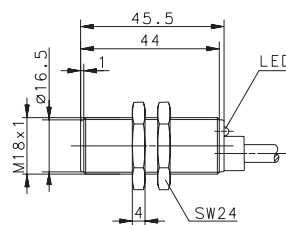
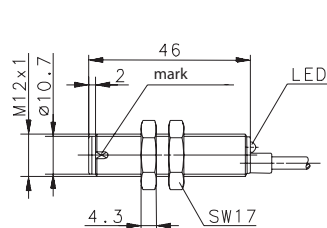

Cable couplings and other accessories can be found from p. 208

Type	5 x 5 x 25 mm	45 x 25.5 x 9 mm	45 x 13 x 9 mm
Enclosure material	CuZn39Pb3	PA, black	PA, black
Operating mode	MR	Hall	MR
Magnetic sensitivity (mT)	3 mT	10 mT	3 mT
Sensing distance (Sn)	10 mm	17 mm	20 mm
Reference magnet (Side)	T-62 N/S	T-62 N/S	T-62 N/S
Type of connection	Cable 2 m	Cable 2 m	Cable 1 m
Special feature			
PNP	NO contact	6373299134	
		MEM-Q05PS/M03-K2	
PNP	NC contact		
PNP	bistable	6373445129	6370401203
		MEK-E45PB/H11-KL2	MEK-E45PB/M03-1
Technical data			
Rated operating voltage range	U_B 4.5–30 VDC	10–39 VDC	10–60 VDC
Rated operating current	I_e 200 mA	400 mA	200 mA
Max. switching voltage	F 10 kHz	10 kHz	20 Hz
Function/operating voltage indicator	–/–	LED/–	–/–
Sensitivity adjustable			
Short circuit-protection	Current limiter	cyclic	–
Mechanical data			
Ambient temperature (min/max)	–20°C/+70°C	–25°C/+70°C	–5°C/+70°C
Protection class in accordance with IEC 529, EN 60529	IP67	IP67	IP67
Connection	3 x 0.05 mm ²	3 x 0.14 mm ²	2 x 0.14 mm ²

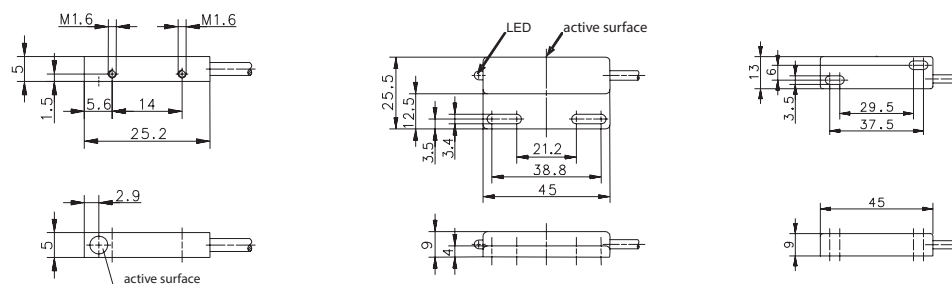

ELECTRONIC MAGNETIC SENSORS Type 50x25x10 mm, 88x25x13 mm



Type		50 x 25 x 10 mm	88 x 25 x 13 mm
Enclosure material		PBT, black	PA, black
Operating mode		Hall	MR
Magnetic sensitivity (mT)		10 mT	3 mT
Sensing distance (Sn)		17 mm	20 mm
Reference magnet (Side)		T-62 N/S	T-62 N/S
Type of connection		Cable 2 m	Cable 1 m
Special feature			
PNP	NO contact	6372290081 MEK-E50PS/H10-KL2	
PNP	NC contact		
PNP	bistable	6373490130 MEK-E50PB/H11-KL2	6370442204 MEK-E90PB/M03-1
Technical data			
Rated operating voltage range	U_B	10–39 VDC	10–60 VDC
Rated operating current	I_e	400 mA	200 mA
Max. switching voltage	F	10 kHz	20 Hz
Function/operating voltage indicator		LED/–	–/–
Sensitivity adjustable			
Short circuit-protection		cyclic	–
Mechanical data			
Ambient temperature (min/max)		–25°C/+70°C	–5°C/+70°C
Protection class in accordance with IEC 529, EN 60529		IP67	IP67
Connection		3 x 0.50 mm ²	2 x 0.50 mm ²

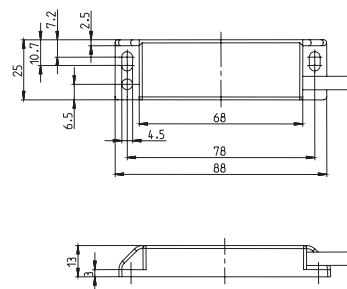
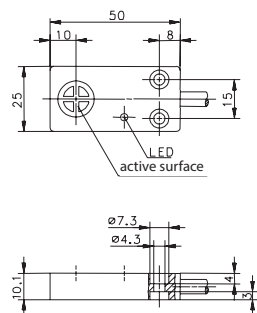

Cable couplings and other accessories can be found from p. 208



Magnetic cylinder sensors

Standard range



Product features

- Type: T-slot/C-slot
- Operating principle: Hall, magnetoresistive, Reed
- Sensitivity: 1.5 – 13.5 mT
- Enclosure material: plastic/aluminium
- Function: IO-Link
Analogue output
Switching points teachable

Good to know ...

The switching points of the 2-channel cylinder sensors can have a teach-in facility. This is done by simply using the supplied teach tool and requires no complex programming.

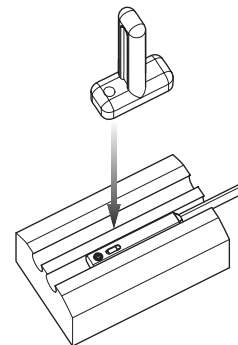

Teach-in output 1

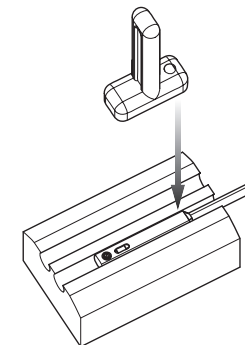

Teach-in output 2

ELECTRONIC CYLINDER SENSORS **TEACHABLE DOUBLE-CHANNEL** Type C-slot, T-slot



Type	C-slot	T-slot
Enclosure material	PA, smoking topaz	Aluminium
Operating mode	Hall	Hall
Magnetic sensitivity (mT)	1.5 – 13.5 mT	1.5 – 13.5 mT
Output	Double-channel	Double-channel
Type of connection	Cable 2 m	Cable 2 m
Special feature	Switching points programmable	Switching points programmable
PNP NO contact	C-slot SMC	6370281183 MEK-E22PS/HP2-KL2
PNP NO contact	C-slot Festo	
PNP NO contact	T-slot	6370299187 MEA-E30PS/HP2-KL2
Technical data		
Rated operating voltage range	U_B 10–30 VDC	10–30 VDC
Rated operating current	I_e ≤ 50 mA	≤ 50 mA
Function/operating voltage indicator	LED/–	LED/–
Sensitivity adjustable	yes	yes
Short circuit-protection	cyclic	cyclic
Teachable	yes	yes
Mechanical data		
Ambient temperature (min/max)	–20°C/+80°C	–20°C/+80°C
Protection class in accordance with IEC 529, EN 60529	IP67	IP67
Connection	4 x 0.05 mm ²	4 x 0.05 mm ²

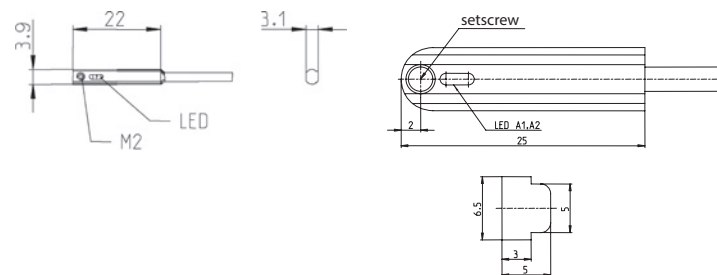

Cable couplings and other accessories can be found from p. 208

ELECTRONIC CYLINDER SENSORS **TEACHABLE SINGLE-CHANNEL Type C-slot, T-slot**



Type	C-slot	T-slot	T-slot
Enclosure material	PA, smoking topaz	Aluminium	Aluminium
Operating mode	Hall	Hall	Hall
Magnetic sensitivity (mT)	1.5 – 13.5 mT	±5 – ±25 mT	1.5 – 13.5 mT
Output	Single-channel	Single-channel	Single-channel
Type of connection	Cable 2 m	Connection cable with plug M12	Connection cable with plug M8
Special feature		IO-Link	Analogue

PNP NO contact	C-slot SMC		
PNP NO contact	C-slot Festo	6372281179 MEK-E22PS/HP1-KL2	
PNP NO contact	T-slot	6370099196 MEA-E30AIOL/H50-KL0,3S12	6370099169 MEA-E30A10/H50-KL0,3S8
Technical data			
Rated operating voltage range	U_B	10–30 VDC	10–30 VDC
Rated operating current	I_e	≤ 50 mA	≤ 50 mA
Function/operating voltage indicator		LED/–	LED/–
Sensitivity adjustable		yes	yes
Short circuit-protection		cyclic	cyclic
Teachable		yes	yes
Mechanical data			
Ambient temperature (min/max)		–20°C/+80°C	+5°C/+55°C
Protection class in accordance with IEC 529, EN 60529		IP67	IP67
Connection		4 x 0.05 mm ²	Connection cable with plug M12 x 1

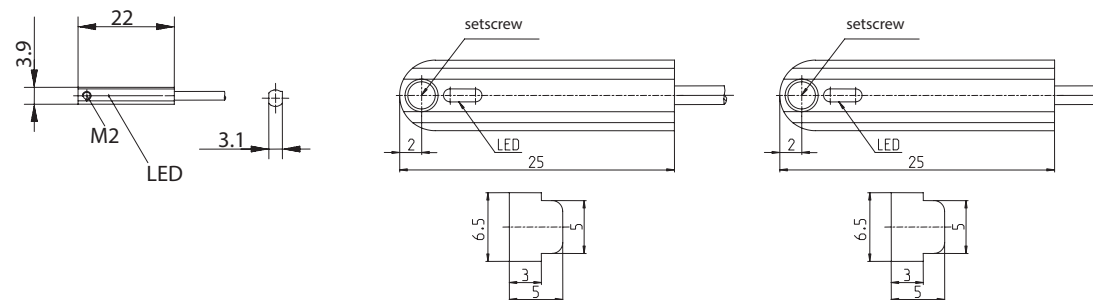

Cable couplings and other accessories can be found from p. 208

ELECTRONIC CYLINDER SENSORS SINGLE-CHANNEL Type C-slot, T-slot



Type	C-slot	C-slot	T-slot	T-slot
Enclosure material	PA, smoking topaz	PA, smoking topaz	Aluminium	Aluminium
Operating mode	Hall	Hall	Hall	Hall
Magnetic sensitivity (mT)	3 mT	3 mT	3 mT	3 mT
Output	Single-channel	Single-channel	Single-channel	Single-channel
Type of connection	Cable 2 m	Connection cable with plug M8	Cable 2 m	Connection cable with plug M8
Special feature				

PNP NO contact	C-slot SMC	6372281172 MEK-E22PS/H03-KL0,3S8		
-----------------------	-------------------	--	--	--

PNP NO contact	C-slot Festo	6372281173 MEK-E22PS/H03-KL2		
-----------------------	---------------------	--	--	--

PNP NO contact	T-slot		6372299175 MEA-E30PS/H03-KL2	6372299176 MEA-E30PS/H03-KL0,3S8
-----------------------	---------------	--	--	--

Technical data				
Rated operating voltage range	U_B	10–30 VDC	10–30 VDC	10–30 VDC
Rated operating current	I_e	≤ 50 mA	≤ 50 mA	≤ 50 mA
Function/operating voltage indicator		LED/–	LED/–	LED/–
Sensitivity adjustable		yes	yes	yes
Short circuit-protection		cyclic	cyclic	cyclic
Mechanical data				
Ambient temperature (min/max)		–20°C/+80°C	–20°C/+80°C	–20°C/+80°C
Protection class in accordance with IEC 529, EN 60529		IP67	IP67	IP67
Connection		3 x 0.05 mm ²	Connection cable with plug M8 x 1	Connection cable with plug M8 x 1

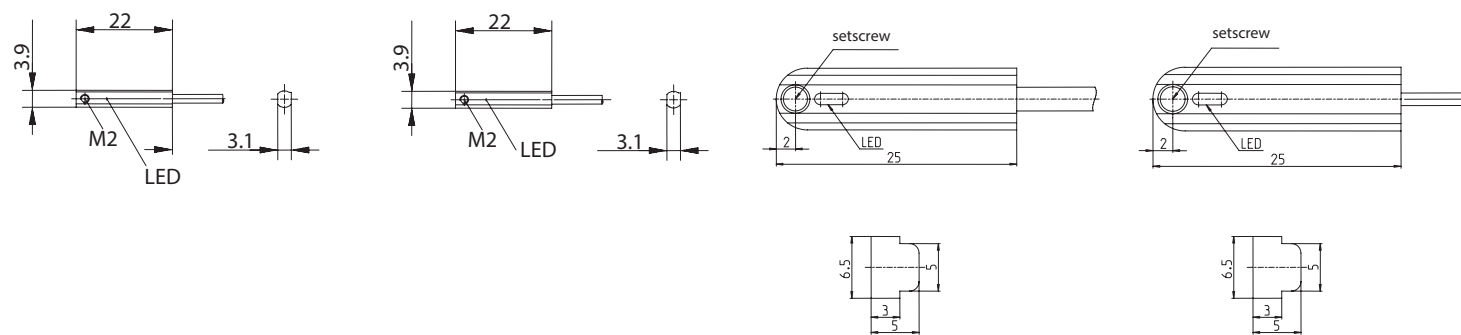

You can find detailed product data sheets at www.bernstein.eu

Magnetic ATEX sensors



Product features

- Type: C-slot/Ø 12 mm
- Switching function: NO contact, Changeover contact
- Enclosure material: plastic
- ATEX: 2G/2D



ELECTRONIC CYLINDER SENSORS ATEX Type C-slot



Type	C-slot	C-slot
Enclosure material	PA, smoking topaz	PA, black
Operating mode	Hall	Hall
Magnetic sensitivity (mT)	1.5 – 13.5 mT	1.5 – 13.5 mT
Output	Double-channel	Double-channel
Type of connection	Cable 2 m	Cable 2 m
Special feature	II 2 G Ex mb IICT6 Gb II 2 D Ex tb IIIC T85°C Db	II 2 G Ex mb IICT6 Gb II 2 D Ex tb IIIC T85°C Db
PNP NO contact	C-slot SMC	C-slot
	6370281197 MEK-E22PS/HP2-KL2-EX	6370281189 MEK-E22PS/HP2-KL2-EX
PNP NO contact	C-slot Festo	
PNP NO contact	T-slot	
Technical data		
Rated operating voltage range	U_B 10–30 VDC	10–30 VDC
Rated operating current	I_e ≤ 50 mA	≤ 50 mA
Function/operating voltage indicator	LED/–	LED/–
Sensitivity adjustable	yes	yes
Short circuit-protection	cyclic	cyclic
Teachable	yes	yes
Mechanical data		
Ambient temperature (min/max)	–20°C/+80°C	–20°C/+80°C
Protection class in accordance with IEC 529, EN 60529	IP67	IP67
Connection	4 x 0.05 mm ²	4 x 0.05 mm ²

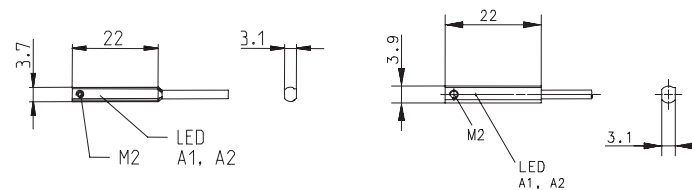

Cable couplings and other accessories can be found from p. 208

ELECTROMECHANICAL MAGNETIC SENSORS ATEX Type Ø 12 mm



Type	Ø 12 mm	Ø 12 mm	Ø 12 mm	Ø 12 mm
Enclosure material	PA, red	PA, red	PA, red	PA, red
Nominal sensing distance	10 mm	10 mm	10 mm	10 mm
Type of connection	Cable 2 m	Cable 3 m	Cable 7 m	Cable 10 m
Reference magnet	T-62 N/S	T-62 N/S	T-62 N/S	T-62 N/S
Special feature	II 2 G Ex mb IIC T6 Gb II 2 D Ex tb IIIC T85 °C Db	II 2 G Ex mb IIC T6 Gb II 2 D Ex tb IIIC T85 °C Db	II 2 G Ex m IIC T6 Gb II 2 D Ex tb IIIC T85 °C Db	II 2 G Ex mb IIC T6 Gb II 2 D Ex tb IIIC T85 °C Db
Changeover contact	6316315308 MAK-1513-LEX-1	6316315001 MAK-1513-LEX-3	6316315344 MAK-1513-LEX-7	6316315654 MAK-1513-LEX-10
Technical data				
Switching voltage (max)	250 V AC / DC	250 V AC / DC	250 V AC / DC	250 V AC / DC
Switching current (max)	1.0 A	1.0 A	1.0 A	1.0 A
Max. switching capacity	20 VA	20 VA	20 VA	20 VA
Function/operating voltage indicator	-/-	-/-	-/-	-/-
Mechanical data				
Ambient temperature (min/max)	-20°C/+60°C	-20°C/+60°C	-20°C/+60°C	-20°C/+60°C
Protection class in accordance with IEC 529, EN 60529	IP67	IP67	IP67	IP67
Connection	3 x 0.75 mm ²	3 x 0.75 mm ²	3 x 0.75 mm ²	3 x 0.75 mm ²

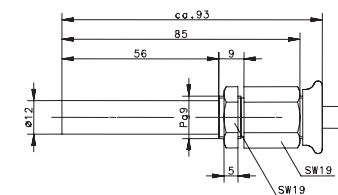
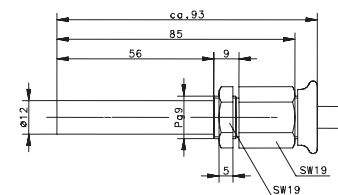
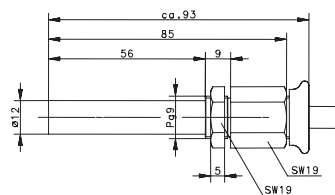
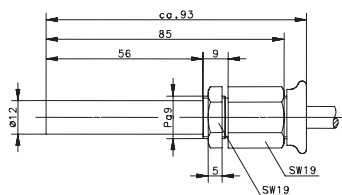



Accessories

Magnets



Product features

- Shapes: round Ø 5 mm – 31 mm/square
- Enclosure: with and without encapsulation/enclosure
- Enclosure material: PA 6.6, PBT, aluminium
- Temperature range: From –40°C to +150 °C

Good to know ...

Permanent magnets can lose their magnetisation if they are exposed to radioactive radiation.

Directions of magnetisation

The term preferred direction refers to the alignment of the magnetic elements in a certain direction. The magnet achieves its highest magnetic values in this preferred direction and must therefore be magnetised in this direction.

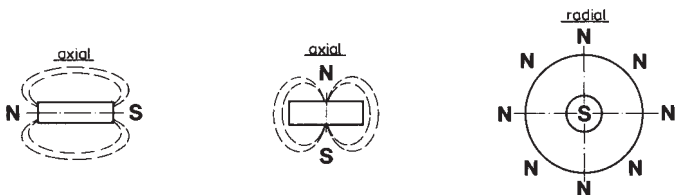

Mounting a magnetic switch system on ferromagnetic materials

The nominal distance may be reduced when magnetic limit switches and their actuating magnets are mounted on magnetisable material (Fe, etc.). To ensure trouble-free operation, a minimum gap of 15 mm between the magnetic switch and any material that can be magnetised should be maintained as a reference value. The same applies to the actuating magnets.

1. Hard ferrite magnets

Barium and strontium hard ferrites are economically priced, reliable components that are also widely used in automation, control and measurement applications.

When operated in high temperature ranges, the specified switching distance will decrease by a factor of 0.2 % per 1 °C.

- **Chemical properties:**

Ferrite magnets are oxide ceramics. They are made of approx. 80 % iron oxide and 20 % barium oxide or strontium oxide. The magnets are resistant to a large number of chemicals, including solvents, caustic solutions and weak acids. If strong organic and inorganic acids, e.g. hydrochloric, sulphuric and hydrofluoric acid, are used, their resistance will basically be determined by the temperature, concentration and reaction time of the medium. In general, the resistance should first be determined by means of long-term tests.

- **Mechanical properties:**

Due to their ceramic characteristic, ferrites are brittle and sensitive to shock and bending loads.

2. Rare-earth magnets

Permanent magnets made from samarium cobalt and neodymium iron boron are high performance and high quality

components that are widely used in drive and control engineering. When operated in high temperature ranges, the specified switching distance will decrease by a factor of 0.02 % per 1 °C.

- **Chemical properties:**

All rare-earth magnets are metallic materials and show the corresponding characteristics associated with these materials, e.g. a polished shine immediately after being machined. The magnets are surface-treated (e.g. nickel coating) to protect them from environmental influences.

- **Mechanical properties:**

Minor chips may occur if rare-earth magnets are subjected to impact stress. They respond very sensitively to vibrations and may become demagnetised.

3. Plastic-bound magnets

Plastic-bound permanent magnets have an attractive price-performance ratio and, thanks to the way they are formed, they can be produced with complex geometries. Injection-moulded magnets are typical composite materials. The magnetic powder is embedded in thermoplastic materials (polyamides). One of the main advantages of plastic-bound magnets is that they can be formed into a wide range of shapes.

- **Chemical properties:**

Surface corrosion can rarely be found on plastic bound magnets. For this reason, they can be used in most fields of application without additional coating.

- **Mechanical properties:**

Plastic-bound magnets can be subjected to buckling and bending without breaking or chipping.

Use in potentially explosive atmospheres

Magnets must not be used in potentially explosive atmospheres as they can cause sparks. Grinding dust and chips from rare-earth magnets are self-igniting and burn off at high temperatures. They should therefore only be machined using ample amounts of water and never in dry conditions since even dried grinding dust can ignite.

Strong magnetic fields

Strong magnetic fields can interfere with or even damage electronic or mechanical equipment. This includes cardiac pacemakers. Appropriate safety distances are specified in the corresponding manuals or may be requested from the manufacturers.

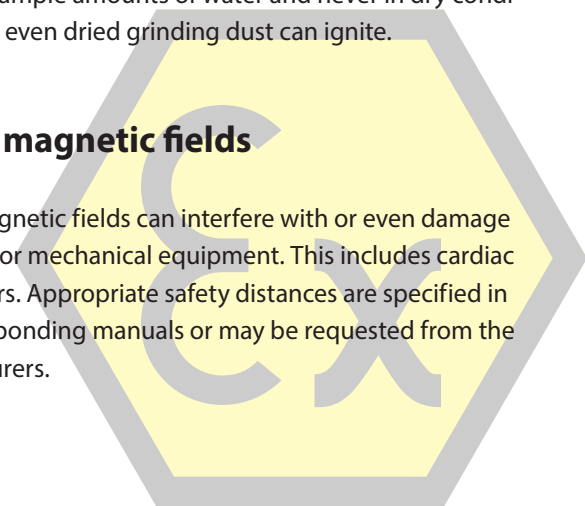

ACCESSORIES ACTUATING MAGNETS WITHOUT ENCAPSULATION

To ensure stable, reproducible actuation, we recommend using our actuating magnets. You can find the exact switch travel in the following table.

T-06 N/S Actuating magnet



Product range	
Article number	Designation
6301106065	T-06 N/S

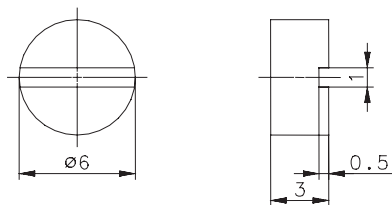

Mechanical data

Magnet material	Neodymium iron boron (NdFeB) (Sn-Ni coating)
Ambient temperature	-40°C ... +150°C

T-61 N/S Actuating magnet



Product range	
Article number	Designation
6301261035	T-61 N/S

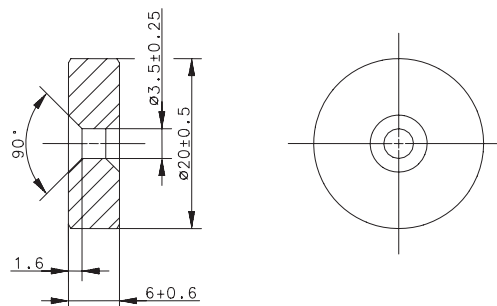

Mechanical data

Magnet material	Barium ferrite Hard ferrite 24/23; axially magnetised; marking on the south-pole side
Ambient temperature	-40°C ... +150°C

T-67 N/S Actuating magnet



Product range	
Article number	Designation
6301167054	T-67 N/S

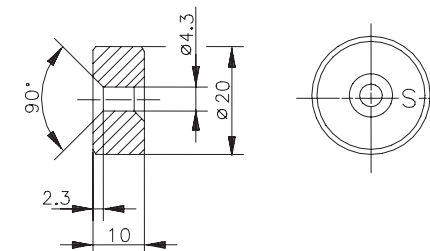

Mechanical data

Magnet material	Hard ferrite 24/23; axially magnetised; marking on the south-pole side
Ambient temperature	-40°C ... +150°C

T-62 N/S Actuating magnet



Product range

Article number	Designation
6301262039	T-62 N/S

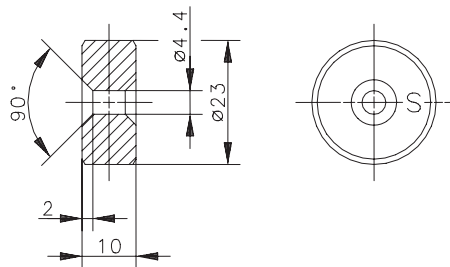

Mechanical data

Magnet material	Hard ferrite 24/16; axially magnetised; marking on the south-pole side
Ambient temperature	-40°C ... +150°C

T-69 N/S Actuating magnet

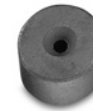

Product range

Article number	Designation
6301269031	T-69 N/S

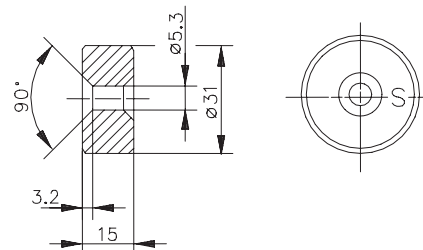

Mechanical data

Magnet material	Hard ferrite 24/16; axially magnetised; marking on the south-pole side
Ambient temperature	-20°C ... +80°C

ACCESSORIES ACTUATING MAGNETS WITHOUT ENCAPSULATION

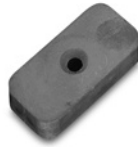

T-68 N Actuating magnet

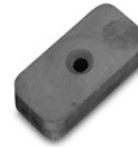

T-68 S Actuating magnet

Product range

Article number	Designation
6301268028	T-68 N

Product range

Article number	Designation
6301368033	T-68 S

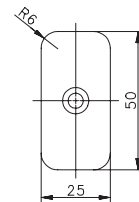
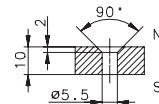
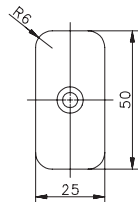
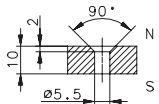

Mechanical data

Magnet material	Hard ferrite 24/16; axially magnetised
Ambient temperature	-20°C ... +80°C

Mechanical data

Magnet material	Hard ferrite 24/16; axially magnetised
Ambient temperature	-20°C ... +80°C

TK-11-11 Actuating magnet



Product range	
Article number	Designation
6302111047	TK-11-11

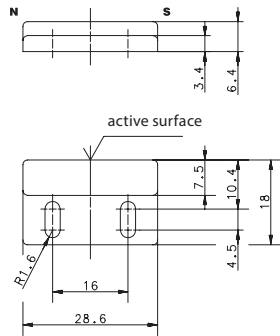

Mechanical data	
Magnet material	AlNiCo – 500
Ambient temperature	-20°C ... +80°C
Enclosure material	PA 6.6, black

TK-11-01 Actuating magnet



Product range	
Article number	Designation
6303111001	TK-11-01

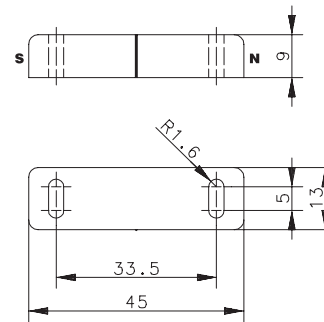

Mechanical data	
Magnet material	AlNiCo – 500
Ambient temperature	-20°C ... +80°C
Enclosure material	PA 6.6, black

TK-21-02 Actuating magnet



Product range	
Article number	Designation
6303121002	TK-21-02

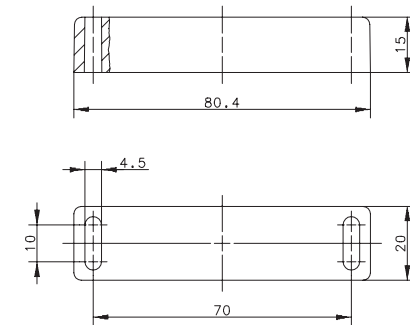

Mechanical data	
Magnet material	AlNiCo – 500
Ambient temperature	-20°C ... +80°C
Enclosure material	PA 6.6, black

ACCESSORIES ACTUATING MAGNETS IN A PLASTIC ENCLOSURE

TK-21-12 Actuating magnet



Product range

Article number	Designation
6302121030	TK-21-12

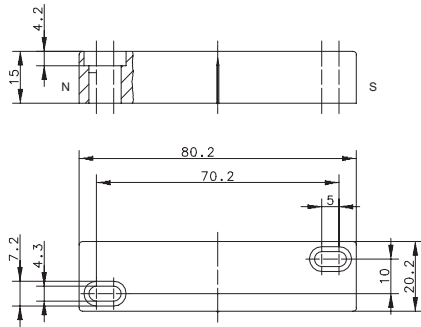

Mechanical data

Magnet material	AlNiCo – 500
Ambient temperature	-20°C ... +80°C
Enclosure material	PA 6.6, red

TK-45 Actuating magnet



Product range

Article number	Designation
6302145048	TK-45

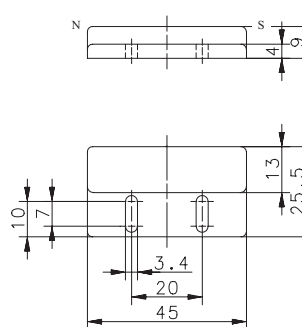

Mechanical data

Magnet material	AlNiCo – 500
Ambient temperature	-20°C ... +70°C
Enclosure material	PA 6.6, black

TK-42 Actuating magnet



Product range

Article number	Designation
6302142049	TK-42

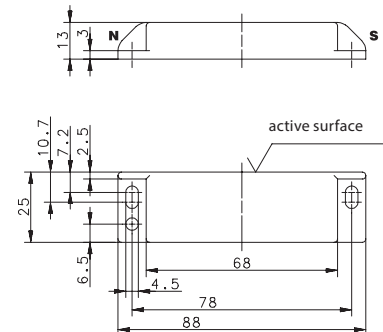

Mechanical data

Magnet material	AlNiCo – 500
Ambient temperature	-20°C ... +80°C
Enclosure material	PA 6.6, black

TK-44 Actuating magnet



Product range

Article number	Designation
6302144050	TK-44

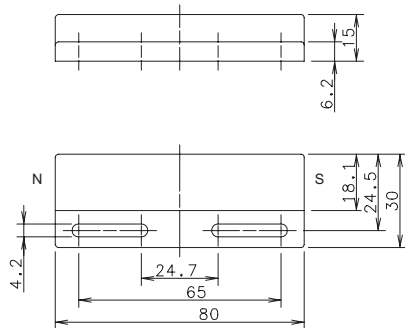

Mechanical data

Magnet material	AlNiCo - 500
Ambient temperature	-20°C ... +80°C
Enclosure material	PA 6.6, black

TK-50 Actuating magnet



Product range

Article number	Designation
6302100053	TK-50

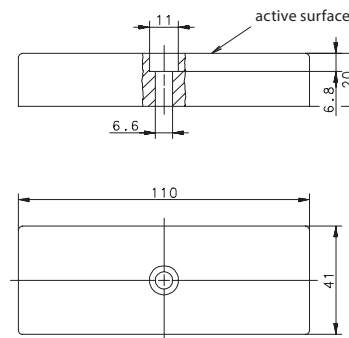

Mechanical data

Magnet material	Hard ferrite
Ambient temperature	-20°C ... +80°C
Enclosure material	PA 6.6, black

TK-57 N Actuating magnet



Product range

Article number	Designation
6302257060	TK-57 N

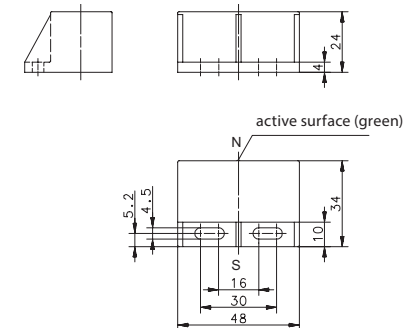

Mechanical data

Magnet material	Hard ferrite
Ambient temperature	-20°C ... +80°C
Enclosure material	PBT, black

ACCESSORIES ACTUATING MAGNETS IN A PLASTIC ENCLOSURE

TK-57 S Actuating magnet



Product range

Article number	Designation
6302357061	TK-57 S

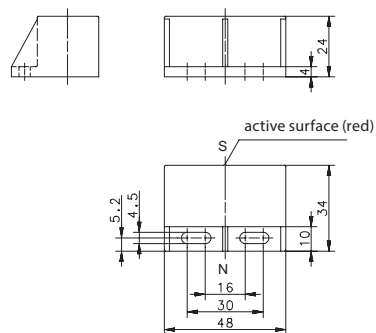

Mechanical data

Magnet material	Hard ferrite
Ambient temperature	-20°C ... +80°C
Enclosure material	PBT, black

TK-21-02 Actuating magnet



Product range

Article number	Designation
6305121064	TK-21-02

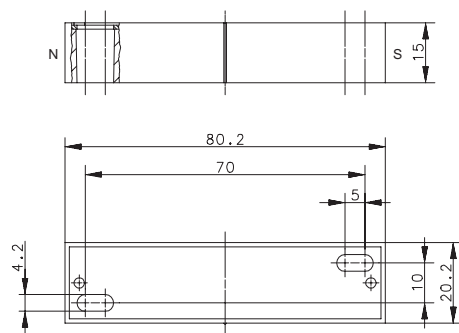

Mechanical data

Magnet material	AlNiCo - 500
Ambient temperature	-40°C ... +150°C
Enclosure material	Al, red

TA-31 Actuating magnet



Product range

Article number	Designation
6303131005	TA-31

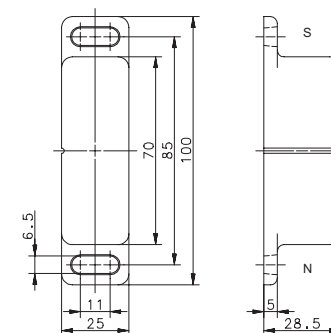

Mechanical data

Magnet material	AlNiCo - 500
Ambient temperature	-20°C ... +80°C
Enclosure material	Al, black

TA-33 Actuating magnet



Product range

Article number	Designation
6303133034	TA-33

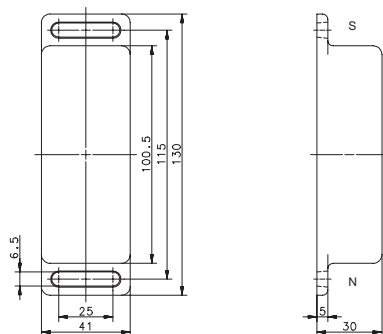

Mechanical data

Magnet material	Hard ferrite 24/16
Ambient temperature	-20°C ... +80°C
Enclosure material	Al, black

ACCESSORIES MOUNTING BRACKETS



BWN-M06NI/40 x 47

Product range

Article number	Designation
4102802001	BWN-M06NI/40 x 47

Mechanical data

Material	Stainless steel 1.4301
for series	MA-06, MA-16, MA-26, MA-15

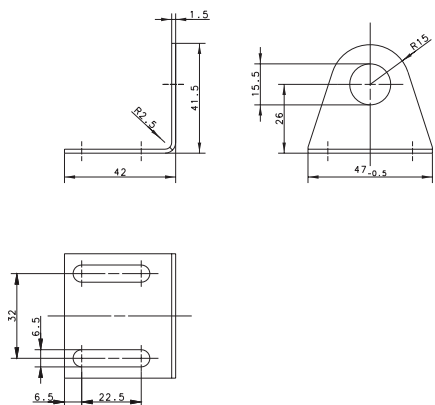

BWN-M06NI/27 x 38

Product range

Article number	Designation
4102802002	BWN-M06NI/27x38

Mechanical data

Material	Stainless steel 1.4301
for series	MA-06, MA-16, MA-26, MA-15

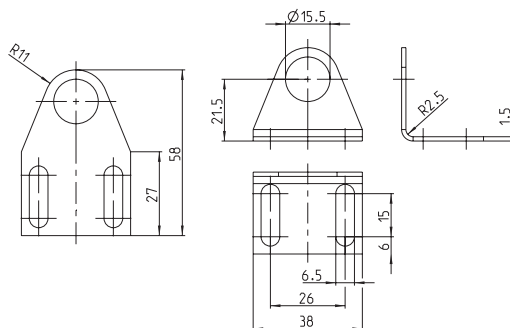

BWN-M36NI

Product range

Article number	Designation
4904700035	BWN-M36NI

Mechanical data

Material	Stainless steel 1.4301
for series	MA-06, MA-16, MA-26, MA-15

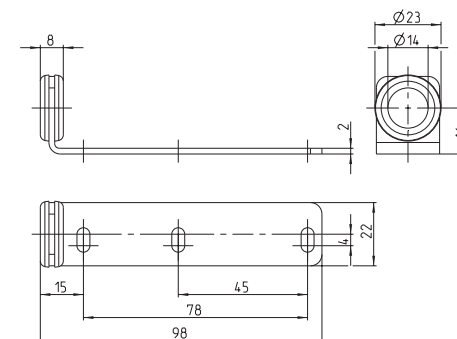

Ø 6.5 mm 3-wire Connector



Product range

Article number	Cable length	Designation
4139100219	2.5 m	GDK-R06US/SO0-2,5PU
4139100220	5 m	GDK-R06US/SO0-5PU

Contact assignments

1 = brown
3 = blue
4 = black

Cable material	PUR
Coupler material	PA 12
Coupling ring material	POM
Temperature range	-25 °C ... +90 °C
Switching function	universal
Cable structure	3 x 0.25 mm ²
Protection class	IP67/NEMA 4

Ø 6.5 mm 3-wire Connector



Product range

Article number	Cable length	Designation
4139100221	2.5 m	WDK-R06US/SO0-2,5PU
4139100222	5 m	WDK-R06US/SO0-5PU

Contact assignments

1 = brown
3 = blue
4 = black

Cable material	PUR
Coupler material	PA 12
Coupling ring material	POM
Temperature range	-25 °C ... +90 °C
Switching function	universal
Cable structure	3 x 0.25 mm ²
Protection class	IP67/NEMA 4

ACCESSORIES CONNECTORS

M8 3-wire Cable connector



Product range		
Article number	Cable length	Designation
4139100213	2 m	WDK-M08PS/LL2-2
4139100216	5 m	WDK-M08PS/LL2-5

Contact assignments

1 = brown
3 = blue
4 = black

Cable material	PVC
Coupler material	TPU
Coupling ring material	CuZn39Pb3
Temperature range	-25/+90 °C
Switching function	PNP/LED
Cable structure	3 x 0.25 mm ²
Protection class	IP67

M8 3-wire Cable connector



Product range		
Article number	Cable length	Designation
4139100795	2 m	GDK-M08US/WO0-2
4139100796	5 m	GDK-M08US/WO0-5
4139100797	10 m	GDK-M08US/WO0-10

Contact assignments

1 = brown
3 = blue
4 = black

Cable material	PVC
Coupler material	PUR
Coupling ring material	CuZn39Pb3
Temperature range	-25/+90 °C
Switching function	universal
Cable structure	3 x 0.25 mm ²
Protection class	IP67

M8 3-wire Cable connector



Product range		
Article number	Cable length	Designation
4139100798	2 m	WDK-M08US/WO0-2
4139100799	5 m	WDK-M08US/WO0-5
4139100800	10 m	WDK-M08US/WO0-10

Contact assignments

1 = brown
3 = blue
4 = black

Cable material	PVC
Coupler material	PUR
Coupling ring material	CuZn39Pb3
Temperature range	-25/+90 °C
Switching function	universal
Cable structure	3 x 0.25 mm ²
Protection class	IP67

M12 3-wire Cable connector



Product range		
Article number	Cable length	Designation
4139100801	2 m	GDK-M12US/WO0-2
4139100802	5 m	GDK-M12US/WO0-5
4139100803	10 m	GDK-M12US/WO0-10

Contact assignments

1 = brown
3 = blue
4 = black

Cable material	PVC
Coupler material	PUR
Coupling ring material	CuZn39Pb3
Temperature range	-25/+90 °C
Switching function	universal
Cable structure	3 x 0.34 mm ²
Protection class	IP67

M12 3-wire Cable connector



Product range		
Article number	Cable length	Designation
4139100804	2 m	WDK-M12US/WO0-2
4139100468	5 m	WDK-M12US/WO0-5
4139100805	10 m	WDK-M12US/WO0-10

Contact assignments

1 = brown
3 = blue
4 = black

Cable material	PVC
Coupler material	PUR
Coupling ring material	CuZn39Pb3
Temperature range	-25/+90 °C
Switching function	universal
Cable structure	3 x 0.34 mm ²
Protection class	IP67

M12 4-wire Cable connector



Product range		
Article number	Cable length	Designation
4139100903	5 m	WDK-M12UA/WO0-5
4139100467	10 m	WDK-M12UA/WO0-10

Contact assignments

1 = brown
2 = white
3 = blue
4 = black

Cable material	PVC
Coupler material	PA
Coupling ring material	CuZn39Pb3
Temperature range	-25/+90 °C
Switching function	universal
Cable structure	4 x 0.25 mm ²
Protection class	IP67

ACCESSORIES CONNECTORS



M12 4-wire Cable connector

Product range		
Article number	Cable length	Designation
4139100244	2 m	WDK-M12PA/SL2-2PU
4139100245	5 m	WDK-M12PA/SL2-5PU
4139100254	10 m	WDK-M12PA/SL2-10PU

Contact assignments

1 = brown
2 = white
3 = blue
4 = black

Cable material	PUR
Coupler material	PUR
Coupling ring material	CuZn39Pb3
Temperature range	-25/+90 °C
Switching function	PNP/LED
Cable structure	4 x 0.25 mm ²
Protection class	IP67



M12 4-wire Cable connector

Product range	
Article number	Designation
4139100102	GDA-M12UA/LO

Cable material	-
Coupler material	PA
Coupling ring material	CuZn39Pb3
Temperature range	-25/+90 °C
Switching function	universal
Cable structure	-
Protection class	IP67



M12 4-wire Cable connector

Product range	
Article number	Designation
4139100101	WDA-M12UA/LO

Cable material	-
Coupler material	PA
Coupling ring material	CuZn39Pb3
Temperature range	-25/+90 °C
Switching function	universal
Cable structure	-
Protection class	IP67



M12 3-wire Cable connector

Product range		
Article number	Cable length	Designation
4139100553	2 m	WDK-M12PS/LL2-2
4139100554	6 m	WDK-M12PS/LL2-6

Contact assignments

1 = brown
3 = blue
4 = black

Cable material	PVC
Coupler material	TPU
Coupling ring material	CuZn39Pb3
Temperature range	-25/+90 °C
Switching function	PNP/LED
Cable structure	3 x 0.4 mm ²
Protection class	IP67



M12 5-wire Cable connector

Product range		
Article number	Cable length	Designation
4139100956	2 m	GDK-M12UU/HO-2PU

Contact assignments

1 = brown
2 = white
3 = blue
4 = black
5 = grey

Cable material	PUR
Coupler material	PUR
Coupling ring material	CuZn39Pb3
Temperature range	-25/+90 °C
Switching function	universal
Cable structure	5 x 0.34 mm ²
Protection class	IP67

TYPE CODE INDUCTIVE SENSORS

1	2	3	4	5	6	7	8	9	10	11	12	13	14	15	16	17	18	19	+
K	I	N	-	T	1	2	N	S	/	0	0	4	-	K	L	2			
Product group			Type of enclosure			Output		Sensing distance			Options								

Product group		
1	K	Non-contact proximity switch
2	I	Inductive
3	B	Flush mount
	N	Non-flush mount
	R	Ring sensor
4	-	Dash (fixed)

Type of enclosure		
5	M	Metric thread (metal enclosure)
	T	Metric thread (plastic enclosure)
	D	Round enclosure (metal)
	R	Round enclosure (plastic)
	Q	Cuboid enclosure (metal)
	P	PG thread (metal)
	E	Rectangular enclosure (plastic)
	S	Slot proximity switch (plastic)
	N	Standard mounting (to DIN 50025/50037)
	C	Compact enclosure
6 - 7		Two-digit number for:
		Round types = Ø as specified
		Threaded types = standard designation
		Rectangular types = consecutive type numbers

Design examples		
	D08	Ø 8 mm (metal)
	R22	Ø 22 mm (plastic)
	M12	Threaded barrel M12 x 1
Rectangular and other types		
	E16	16 x 5 x 5 mm
	E27	27 x 10 x 5,5 mm
	E28	28 x 16 x 11 mm
	E40	40 x 26 x 12 mm
	E50	50 x 25 x 10 mm
	E68	68 x 30 x 15 mm
	G00	Tube thread, general
	N44	41,5 x 41,5 x 120 mm
	Q05	5 x 5 x 25 mm
	Q08	8 x 8 x 40 mm, Side active
	Q12	12 x 12 x 55 mm

Output		
8	P	PNP
	N	NPN
	A	AC 2-wire
	E	NAMUR
	Z	DC 2-wire
	R	Relay
	G	Push-pull
	D	Dual output stage (NPN/PNP selectable)
9	S	NO contact
	Ö	NC contact
	P	Programmable
	A	Analogue
	U	Antivalent (selectable)
10	/	Slash (fixed)

Sensing distance		
11 - 13	e.g. 1,5	1,5 mm
	e.g.002	2,0 mm
	e.g. 040	40 mm
14	-	Dash (fixed)
Options		
15 - 17		See type code "OPTIONS", p. 229

TYPE CODE CAPACITIVE SENSORS



1	2	3	4	5	6	7	8	9	10	11	12	13	14	15	16	17	18	19	+
K	C	N	-	T	1	2	N	S	/	0	0	4	-	K	L	P	2		
Product group			Type of enclosure			Output		Sensing distance			Options								

Product group		
1	K	Non-contact proximity switch
2	C	Capacitive
3	B	Flush mount
	N	Non-flush mount
4	-	Dash (fixed)

Type of enclosure		
5	M	Metric thread (metal enclosure)
	T	Metric thread (plastic enclosure)
	D	Round enclosure (metal)
	R	Round enclosure (plastic)
	Q	Cuboid enclosure (metal)
	P	PG thread (metal)
	E	Rectangular enclosure (plastic)
	N	Standard mounting (to DIN 50025/50037)
6 - 7		Two-digit number for:
		Round types = Ø as specified
		Threaded types = standard designation
		Rectangular types = consecutive type numbers

Design examples		
	12	Thread M12 x 1
	18	Thread M18 x 1
	30	Thread M30 x 1,5
	32	Thread M32 x 1,5
	34	Ø 34 mm (metal/plastic)
	20	Ø 20 mm (plastic)
	22	Ø 22 mm (plastic)
	50	50 x 25 x 10 mm
	68	68 x 30 x 15 mm
	44	41.5 x 41.5 x 120 mm (Euro standard enclosure)

Output		
8	P	PNP
	N	NPN
	A	AC 2-wire
	E	NAMUR
	Z	DC 2-wire
	R	Relay
	G	Push-pull
	D	Dual output stage (NPN/PNP selectable)

Output		
9	S	NO contact
	Ö	NC contact
	P	Programmable
	A	Analogue
	U	Antivalent (selectable)
10	/	Slash (fixed)
Sensing distance		
11 - 13	e.g. 1,5	1,5 mm
	e.g. 002	2,0 mm
	e.g. 040	40 mm
14	-	Dash (fixed)
Options		
15 - 19		See type code "OPTIONS", p. 229

TYPE CODE MAGNETIC SWITCHES

1	2	3	4	5	6	7	8	9	10	11	12	13	14	15	16	17		
M	A	K	-	0	1	1	2	-	D	-	1	-	S	O	K			
Product group			Type			Contact specifications				Cable length		Special features						

Product group		
1	M	Magnetic switch
2	Type of output	
	A	Reed contact
	R	Relay
3	Enclosure material	
	A	Aluminium
	N	Stainless steel
	M	Brass, nickel-plated
	K	Plastic, general
	O	Other materials
4	-	Dash (fixed)
Type		
5 – 6	01 – 99	Cylindrical and rectangular types (see next page for details)
Contact specifications		
7	Number of contacts	
	e.g. 1	1 Reed contact
	e.g. 2	2 Reed contacts
	...	etc.

8	Contact function	
	1	NC contact
	2	NO contact
	3	Changeover contact
	4	Bistable (ON/OFF)
	5	Bistable (changeover contact)
	6	NC, NO contact; separate contacts
	7	Coded, BG
	8	Currently not used
	9	Currently not used
	0	Other outputs
9	-	Dash (fixed)
10	Contact type/power of reed contacts	
	A	250 VDC ; 0,5 A; 20 VA
	B	250 VDC ; 0,5 A; 10 VA
	C	250 VDC ; 0,5 A; 30 VA
	D	250 VDC ; 0,5 A; 30 VA
	E	250 VDC ; 1,5 A; 30 VA
	F	250 VDC ; 3,0 A; 100 VA
	G	250 VDC ; 5,0 A; 250 VA
	H	250 VDC ; 1,0 A; 60 VA

	K	250 VDC ; 0,5 A; 30 VA
	L	250 VDC ; 1,0 A; 60 VA
	M	250 VDC ; 1,0 A; 80 VA
	N	250 VDC ; 1,0 A; 60 VA
	O	120 VDC ; 0,5 A; 10 VA
	P	250 VDC ; 5,0 A; 250 VA
	R	28 VDC ; 0,25 A; 3 VA
	W	250 VDC ; 1,0 A; 60 VA
	X	100 VDC ; 0,25 A; 5 VA
	Y	100 VDC ; 0,5 A; 10 VA
	TRIAC	
	K	24 – 250 VDC ; 1,5 A a. 300 VA b. 330 VA
	Hall	
11	-	Dash (fixed)

Cable length in metres		
12	e.g. 1	1 m cable
	e.g. 2	2 m cable
	...	etc.
13	-	Dash (fixed)
Special features		
14 – 17	T	Temperature resistant from –40 °C to +150 °C
	SI	With miniature fuse
	VDR	With VDR
	WID	With resistor
	LED	With LED
	SPK	Spiral cable
	SK	Special cable
	SOK	Connector type without head (without device socket)
	SMK	Connector type with head (with device socket)
	PG11	Type of thread
	RZ	Time delay with relay
	220 V	220 Volt version
	24 V	24 Volt version
	STK	Connector

TYPE CODE MAGNETIC SWITCHES



1	2	3	4	5	6	7	8	9	10	11	12	13	14	15	16	17		
M	A	K	-	0	1	1	2	-	D	-	1	-	S	O	K			
Product group			Type			Contact specifications			Cable length			Special features						

Type		
5-6	01-99	Cylindrical and rectangular types
	01	45 x 13 x 9 mm [MA-01] PA
	02	80 x 20 x 15 mm [MA-02] PA/AL
	03	110 x 58 x 29 mm [MA-03] AL
	04	∅ 15.5 x 87 mm [MA-04] PC
	05	Currently not used
	06	∅ 12 x 81 mm [MA-06] AL
	07-10	Currently not used
	11	28.6 x 18 x 6.4 mm [MA-11] PA
	12	80 x 20 x 15 mm [MA-12] PA
	13	68 x 30 x 15 mm [MA-13] PC
	14	Currently not used
	15	∅ 12 x 81 mm [MA-15] PA
	16	∅ 12 x 81 mm [MA-13] VA
	17	PG9 x 60 mm [MA-17] PA
	18	M12 x 1 x 60 mm [MA-18] Ms
	19	M18 x 1 x 80 mm [MA-19] Ms
	20	Currently not used
	21	PG9 x 80 mm [MA-21] PA
	22	Currently not used

	23	M12 x 1 x 80 mm [MA-23] Ms
	24/25	Currently not used
	26	∅ 12 x 81 mm [MA-26] PA
	27	Currently not used
	28	M12 x 1 x 60 mm [MA-28] PA
	29	M18 x 1 x 80 mm [MA-29] PA
	30	∅ 6 x 30 mm [MA-30] PA
	31	Currently not used
	32	85 x 26 x 26 mm [MA-32] PBT
	33	M12 x 1 x 80 mm [MA-33] PA
	34/35	Currently not used
	36	∅ 13 x 96 mm [MA-36] PA
	37-39	Currently not used
	40	M10 x 1 x 40 mm [MA-40] PPE
	41	50 x 31 x 11 mm [MA-41] PA
	42	88 x 25 x 13 mm [MA-42] PA
	43	PG9 x 80 mm [MA-43] Ms
	44	80 x 30 x 15 mm [MA-44] PA
	45	45 x 25.5 x 9 mm [MA-45] PA
	46	∅ 6.5 x 39.34 mm [MA-46] PA
	47	Currently not used
	48	80 x 30 x 15 mm [MA-48] PA

	49-51	Currently not used
	52	43 x 26 x 13 mm [MA-52] PBT
	53	M30 x 1.5 mm [MA-53] PA
	54	Currently not used
	55	12 x 12 x 55 mm [MA-55] S
	56-59	Currently not used
	60	M8 x 1 mm [MA-60] S
	61	M10 x 1 mm [MA-61] S
	62	M12 x 1 mm [MA-62] S
	63	M18 x 1 mm [MA-63] S
	64	M30 x 1.5 mm [MA-64] S
	65-69	Currently not used
	70	∅ 6.5 mm [MA-70] S
	71/72	Currently not used
	73	68 x 30 x 15 mm [MA-73] S
	74-79	Currently not used
	80	8 x 8 x 40 mm [MA-80] S
	81-98	Currently not used
	99	other [MA-99] S

TYPE CODE **MAGNETIC SENSORS / CYLINDER SENSORS ELEKTRONIC / TEACHABLE**

1	2	3	4	5	6	7	8	9	10	11	12	13	14	15					
M	E	K	-	M	1	2	P	S	/	H	1	0	-	K	L	2			
Product group			Type of enclosure			Output		Sensitivity			Options								

Product group		
1	M	Magnetic sensor
2	E	Electronic
3	K	Plastic
	M	Brass
	N	Stainless steel
4	-	Dash (fixed)
Type of enclosure		
5	M	Metric thread
	D	Round enclosure
	E	Rectangular enclosure
	Q	Cuboid enclosure
6-7		Two-digit number for:
		Metric enclosure = standard designation
		Round enclosure = Ø as specified
		Rectangular enclosure = enclosure width
		Cuboid enclosure = edge length

Output		
8	P	PNP
	N	NPN
9	S	NO contact
	Ö	NC contact
	B	Bistable
	A	Analogue
	D	Speed
10	/	Slash (fixed)
Sensitivity		
11	H	Hall
	M	Magneto-resistive
12-13		Sensitivity in mT
	z. B. 10	10 mT
	z. B. 01	1 mT
14	-	Dash (fixed)
Options		
15		See type code "OPTIONS", p. 229

TYPE CODE OPTIONS

1	2	3	4	5	6	7	8	9	10	11	12	13	14				
K	L	2	E	V	P	S	N	T	F	Z	I	D	G				

1	K	Short circuit-proof
2	L	LED
3	2	Cable length in m
4	E	Extended sensing distance (sn large)
5	V	Shortened type
6	P	Potentiometer
7	S	Device connector (terminals)
	PU	PUR cable
	SD	Connector to DIN 43650 (including socket)
	SM	Mini snap-in device connector
	S8	M8 device connector with union nut
	S12	M12 device connector with union nut
	SM8	Mini snap-in / M8 screw-on device connector
	S12A	M12 device connector with union nut, AC version

	S16S	M16 device connector with union nut and dust cap
	S12U	M12 Ultra-Lock device connector
	S5	M5 x 0,5 device connector Screw-connection with cable
8	N	Stainless steel enclosure
9	T	Extended temperature range
10	F	Extended switching frequency
11	Z	Time-delayed
12	I	Programmable (intelligent)
13	D	ATEX products, dust Ex
14	G	ATEX products, gas Ex

TYPE CODE **CABLE CONNECTORS**

1	2	3	4	5	6	7	8	9	10	11	12	13	14	15	16	17			
W	D	K	-	M	1	2	P	S	/	L	L	2	-	2	P	U			
Device specifications				Type of connection			Classification				LEDs			Cable length	Options				

Device specifications		
1		Cable output
	W	Elbow
	G	Straight
2		Product group
	D	Socket
	S	Connector (the sensor connections should always be used as the basis for connecting lines with different outputs)
	A	Adapter (socket and connector)
3		Preassembly
	K	Fixed cable
	A	Connection space, self-configurable
	V	Connecting line (extension)
4	-	Dash (fixed)

Type of connection		
5 - 7		Always related to the socket / connector
	M12	Union nut M12 x 1
	M08	Union nut M8 x 1
	R06	Round snap-in connection Ø 6.5 mm
	R12	Round snap-in connection, Ultra-Lock M12
	M05	M5 x 0.5 screw-on connection

Classification		
8		Configuration for switch output
	P	PNP (LED to negative)
	N	N = NPN (LED to positive)
	U	Universal (no LED)
	A	AC (M12 special coding Pin 1 + 2)
9		Pin assignments of cable sockets for switch output
	S	NO contact 1 - 3 - 4 for M12 1 - 3 - 2 for Mini 1 - 2 for M12 AC
	Ö	NC contact 1 - 3 - 2 for M12
	A	Antivalent 1 - 3 - 4 - 2 for M12
	N	NAMUR 1 - 3 for M12
	U	More than 4 connections
	T	Teach-in function
10	/	Slash (fixed)
Manufacturer		
11		Internal information

LEDs		
12	L	Integrated LED
	O	Without LED
13		Number of LEDs
	0	No LED
	1	1 LED
	2	2 LEDs etc.
14	-	Dash (fixed)
Cable length		
15		In m (moulded cable)
Options		
16 - 17	PU	Polyurethane cable
	HF	Highly flexible cable
	SD	Connector/socket
	BD	Socket both ends
	R	Vibration safeguard
	Without	PVC cable

TYPE CODE MOUNTING MATERIAL

1	2	3	4	5	6	7	8	9												
B	K	S	-	D	2	0	P	A												
Product group				Type group			Material													

Product group		
1	B	Mounting material
2		Type of product
	K	Retaining bracket
	W	Mounting bracket
	H	Retaining plate
3		Specification
	S	Bracket, 2-piece
	B	Block, 1-piece
	R	Reducer
	N	90° elbow
4	-	Dash (fixed)

Type group		
5 - 7		For clips:
		Diameter in mm corresponding to matching sensor
		For elbows:
		Type group
	z. B. L05	Light barrier OR05
	z. B. M06	Magnetic switch M06
Material		
8 - 9		Material
	ST	Steel
	NI	Stainless steel
	AL	Aluminium
	PA	Polyamide
	PP	Polypropylene

BERNSTEIN WORLDWIDE

Your contacts



**BERNSTEIN AG – Headquarters and Logistics centre
Germany**

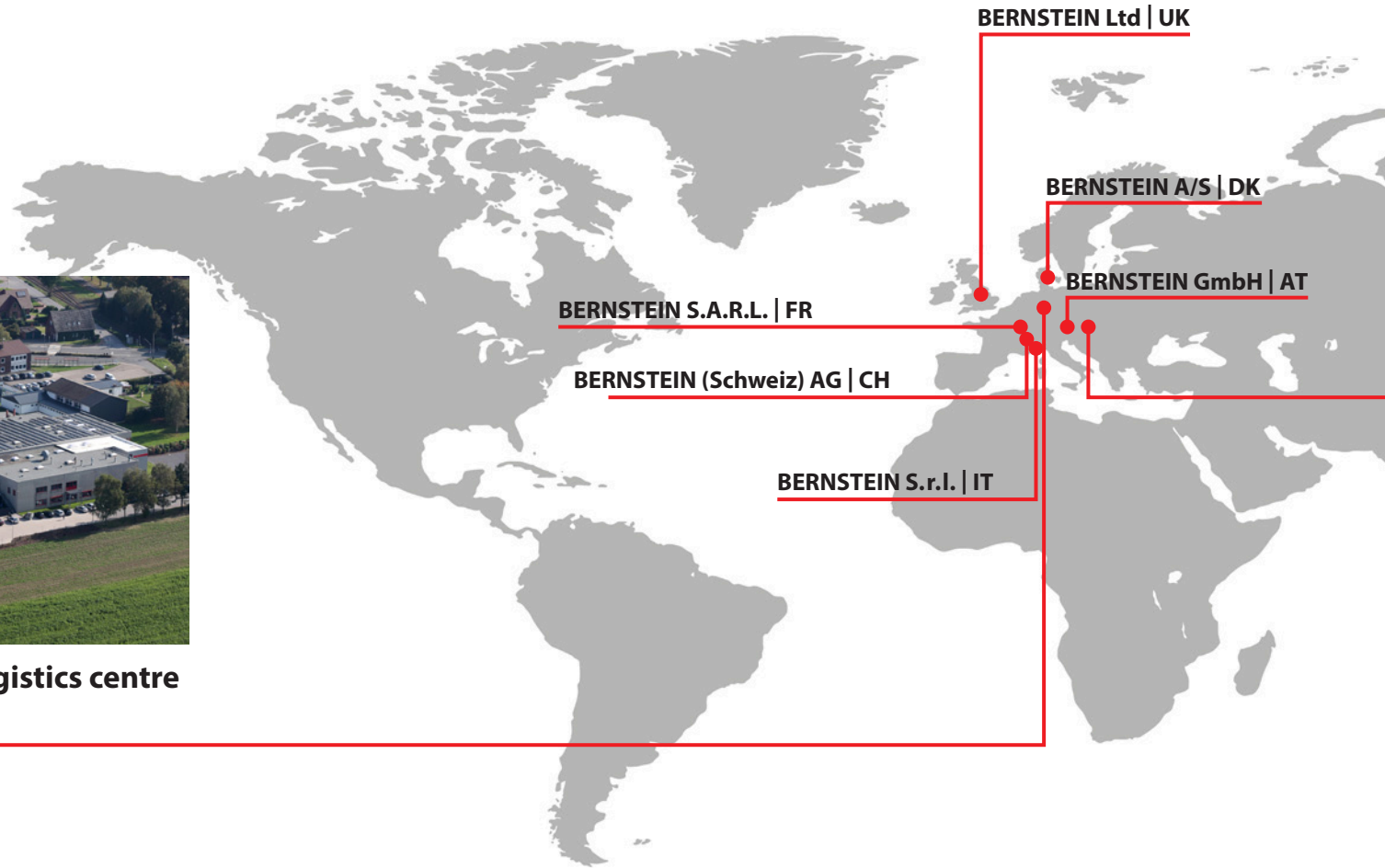

Your contact partners

International Headquarters

BERNSTEIN AG
Hans-Bernstein-Str. 1
32457 Porta Westfalica
Phone +49 571 793-0
info@bernstein.eu
www.bernstein.eu

Denmark

BERNSTEIN A/S
Phone +45 7020 0522
info.denmark@bernstein.eu
www.bernstein.dk

Italy

BERNSTEIN S.r.l.
Phone +39 035 4549037
sales@bernstein.it
www.bernstein.it

France

BERNSTEIN S.A.R.L.
Phone +33 1 64 66 32 50
info.france@bernstein.eu
www.bernstein.fr

Austria

BERNSTEIN GmbH
Phone +43 2256 62070-0
office@bernstein.at
www.bernstein.at

United Kingdom

BERNSTEIN Ltd
Phone +44 1922 744999
sales@bernstein-ltd.co.uk
www.bernstein-ltd.co.uk

Switzerland

BERNSTEIN (Schweiz) AG
Phone +41 44 775 71-71
info.schweiz@bernstein.eu
www.bernstein-schweiz.ch

China

**BERNSTEIN Safe Solutions
(Taicang) Co., Ltd.**
Phone +86 512 81608180
info@bernstein-safesolutions.cn
www.bernstein-safesolutions.cn



BERNSTEIN Kft. | Hungary



**BERNSTEIN Safe Solutions
(Taicang) Co., Ltd. | China**

8
4
1

SUBSIDIARIES
are at your disposal at our
international locations

PRODUCTION FACILITIES
in Germany, China and Hungary
are manufacturing products at the
highest level for our international
customers

TEAM
with one common objective
— your satisfaction

www.bernstein.eu/en/contact



