

# BASORFIL

## Cable Tray Installation

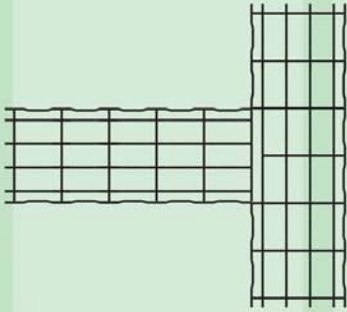

T/CROSS

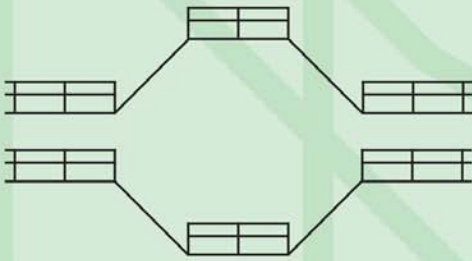

CHANGING LEVEL

## HOW TO CUT

Always use asymmetrical-cut wire cutters.

Cut as close as you can to where horizontal and vertical rods cross each other, as shown.

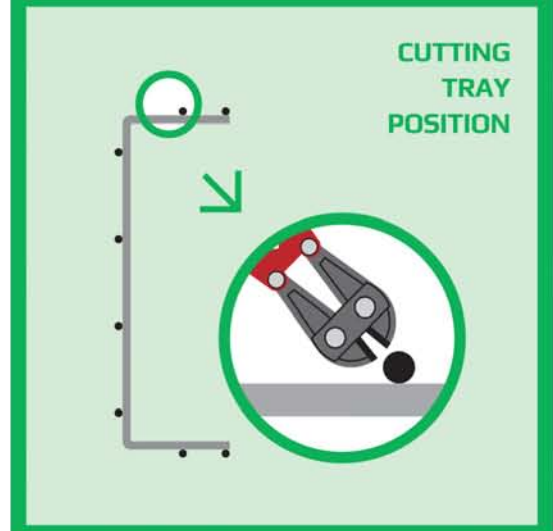
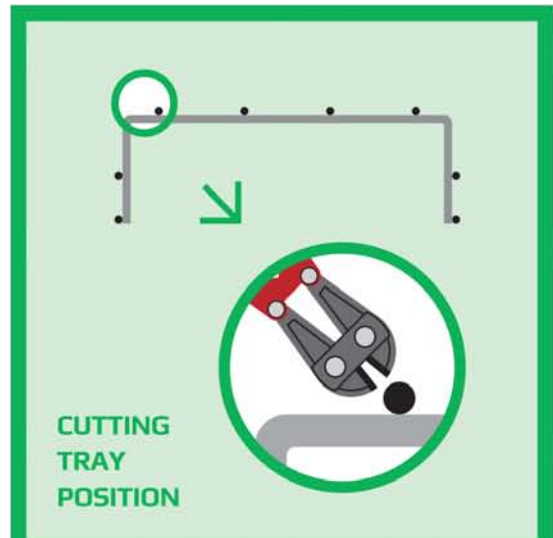
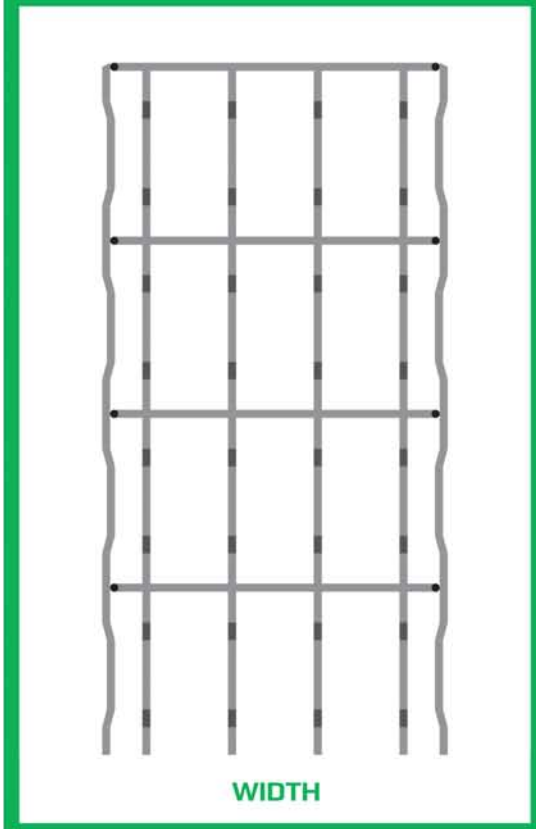
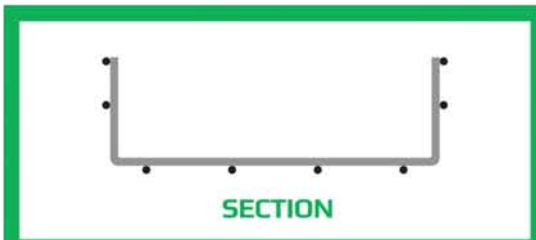
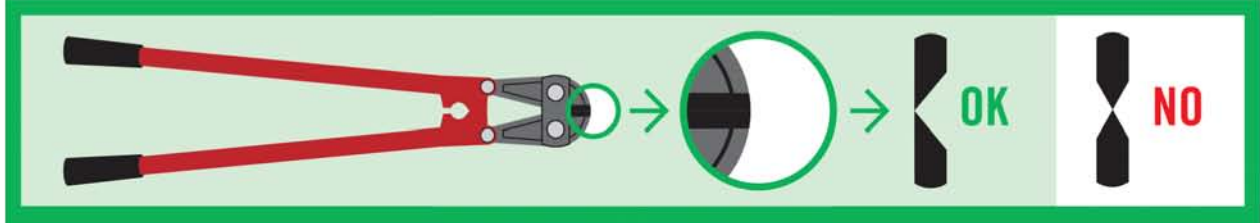

LARGE 90° RADIUS HORIZONTAL BENDS

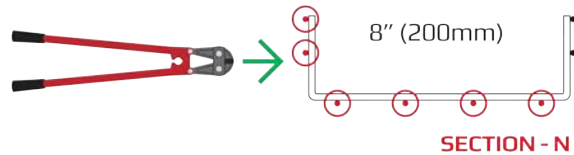
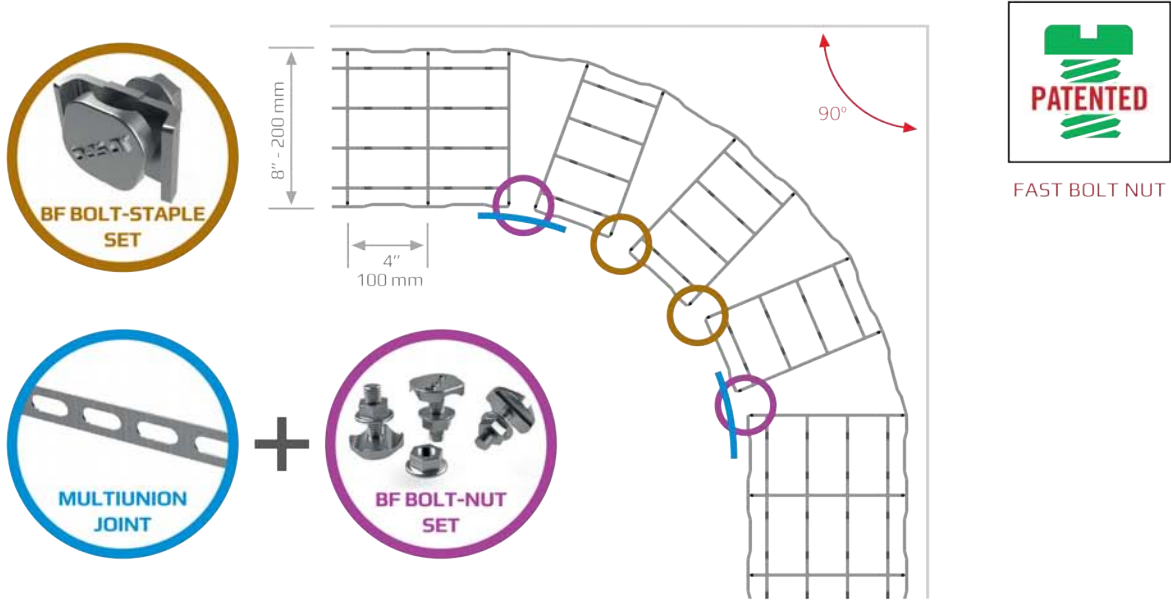

WIDTH	N	ACCESSORIES	RADIUS		USED LENGTH	
			inches	mm	inches	mm
2"	50mm	2x (BF Bolt-Nut Set + Multiunion joint)	-	-	5x4"	5x100
4"	100mm	3x (BF Bolt-Nut Set + Multiunion joint)	8'65	220	7x4"	7x100
6"	150mm	4x (BF Bolt-Nut Set + Multiunion joint)	11'03	280	9x4"	9x100
8"	200mm	[2x (2x BF Bolt-Nut Set + Multiunion joint) + 2x ( Bolt-Staple Set)]	11'03	280	9x4"	9x100
12"	300mm	[2x (2x BF Bolt-Nut Set + Multiunion joint) + 4x ( Bolt-Staple Set)]	16'92	430	13x4"	13x100
16"	400mm	[2x (2x BF Bolt-Nut Set + Multiunion joint) + 6x ( Bolt-Staple Set)]	18'11	460	17x4"	17x100
20"	500mm	9x ( Bolt-Staple Set)	27'56	700	19x4"	19x100
24"	600mm	11x ( Bolt-Staple Set)	30'31	770	23x4"	23x100

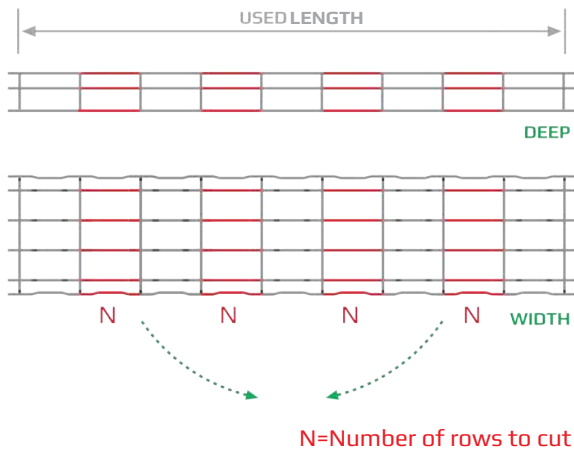

## LARGE 90° RADIUS HORIZONTAL BENDS

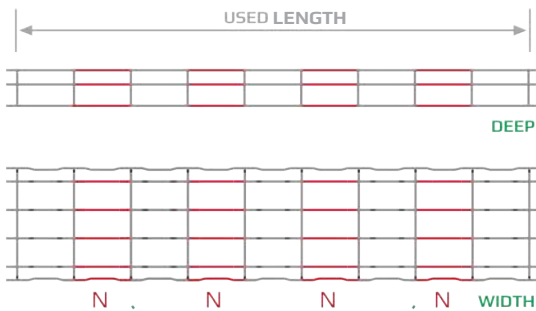
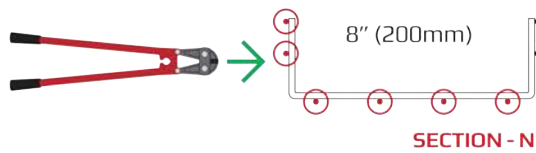
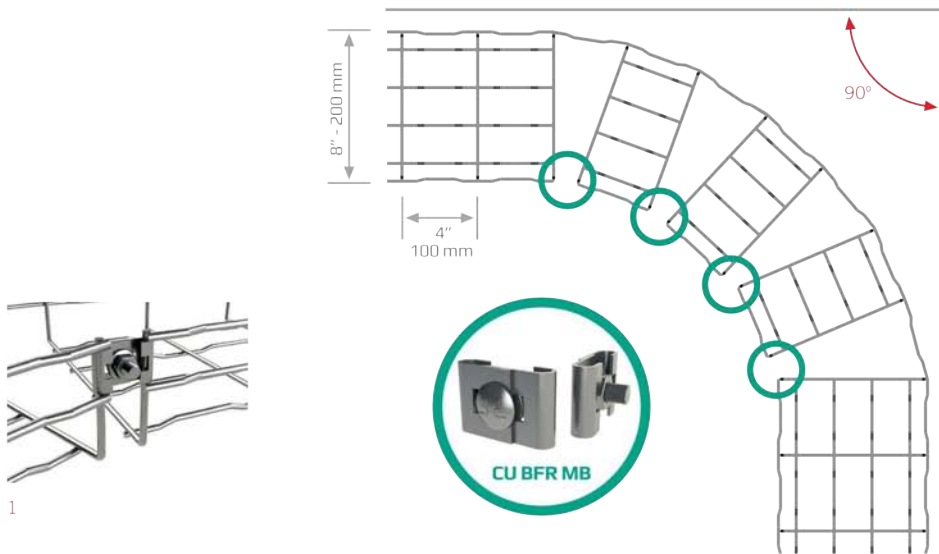

N=Number of rows to cut

WIDTH	N	SPLICE	RADIUS		USED LENGTH	
			inches	mm	inches	mm
4"	100mm	CU BFR MB	5'51	140	5x4"	5x100
6"	150mm	CU BFR MB	8'65	220	7x4"	9x100
8"	200mm	CU BFR MB	11'81	300	9x4"	9x100
12"	300mm	CU BFR MB	17'72	450	13x4"	13x100
16"	400mm	CU BFR MB	24	610	17x4"	17x100
20"	500mm	CU BFR MB	29'92	760	21x4"	21x100
24"	600mm	CU BFR MB	35'83	910	25x4"	25x100

SMALL 90° RADIUS HORIZONTAL BENDS

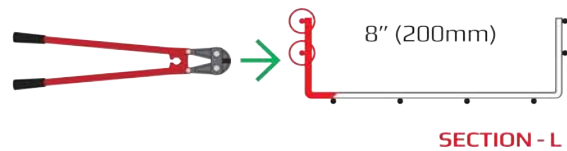
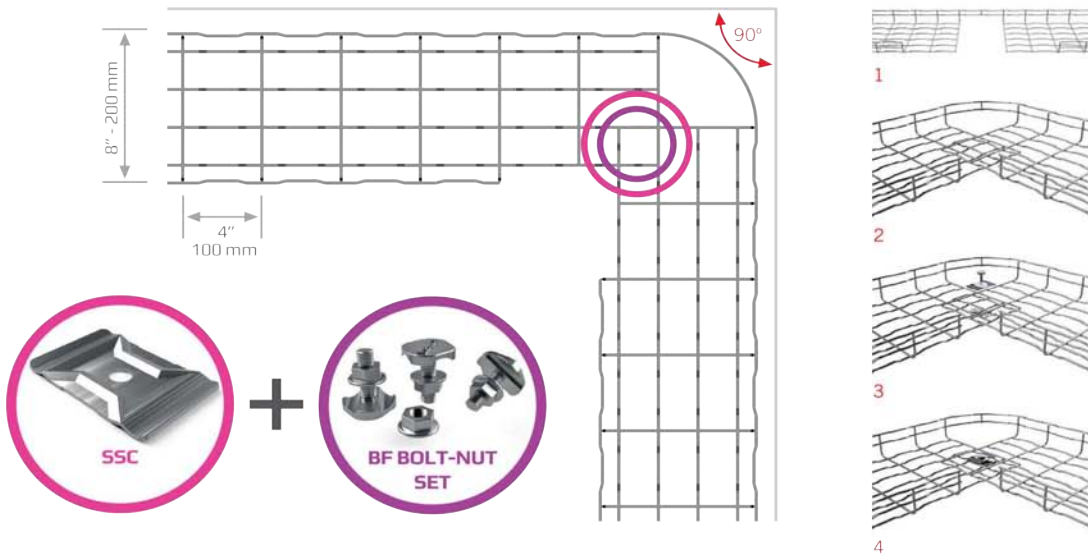

WIDTH	D	L	ACCESSORIES	RADIUS		USED LENGTH		
				inches	mm	inches	mm	
2"	50mm	-	1x BF Bolt-Staple Set	-	-	3x4"	3x100	
4"	100mm	1	1+1	1x BF Bolt-Staple Set	2	50	5x4"	5x100
6"	150mm	1	2+2	1x (2 SSC+BF BOLT-NUT SET)	4'72	120	7x4"	7x100
8"	200mm	2	2+2	1x (2 SSC+BF BOLT-NUT SET)	4'92	125	8x4"	8x100
12"	300mm	2	3+3	1x (2 SSC+BF BOLT-NUT SET)	4'72	120	10x4"	10x100
16"	400mm	2	4+4	1x (2 SSC+BF BOLT-NUT SET)	5'12	130	12x4"	12x100
20"	500mm	2	5+5	1x (2 SSC+BF BOLT-NUT SET)	5'12	130	14x4"	14x100
24"	600mm	2	6+6	1x (2 SSC+BF BOLT-NUT SET)	5'31	135	16x4"	16x100

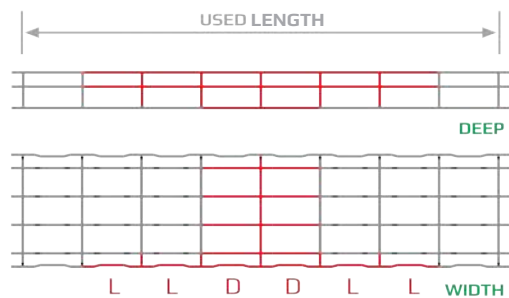

D and L=Number of rows to cut

## 90° RADIUS HORIZONTAL BENDS

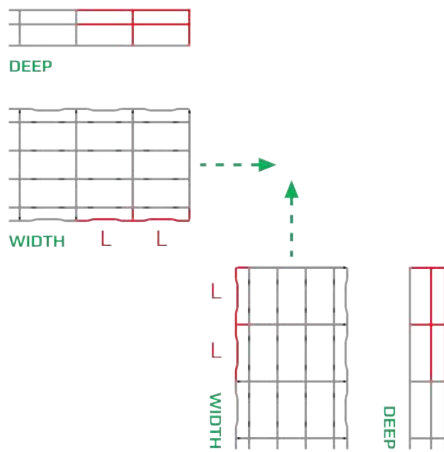
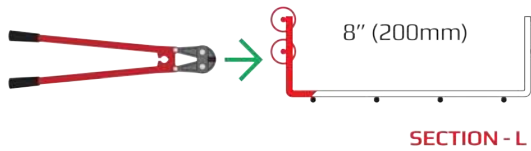
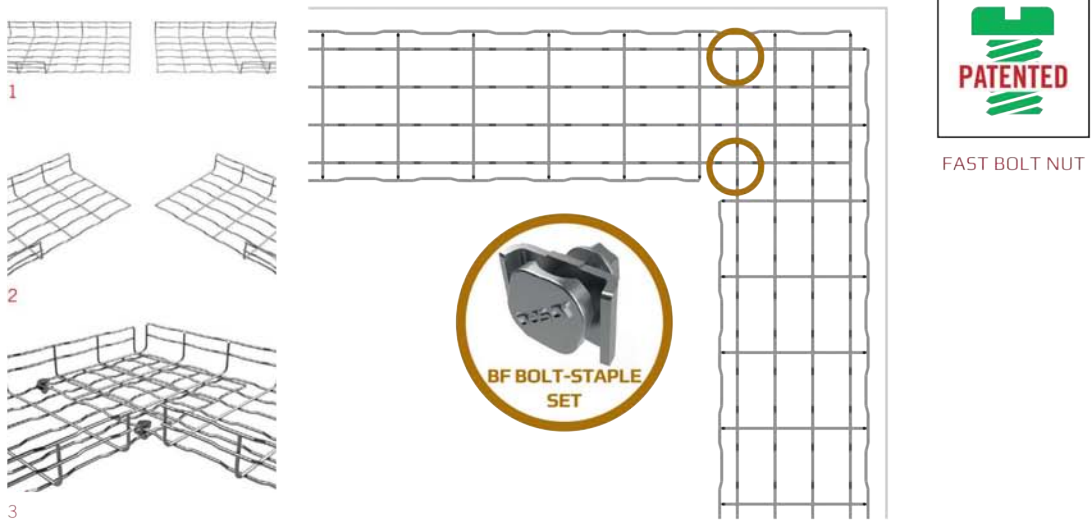

L=Number of rows to cut

WIDTH	L	ACCESSORIES	
4"	100mm	1	2x BF Bolt-Staple Set
6"	150mm	2	2x BF Bolt-Staple Set
8"	200mm	2	2x BF Bolt-Staple Set
12"	300mm	3	2x BF Bolt-Staple Set
16"	400mm	4	2x BF Bolt-Staple Set
20"	500mm	5	2x BF Bolt-Staple Set
24"	600mm	6	2x BF Bolt-Staple Set

TEE OR CROSS

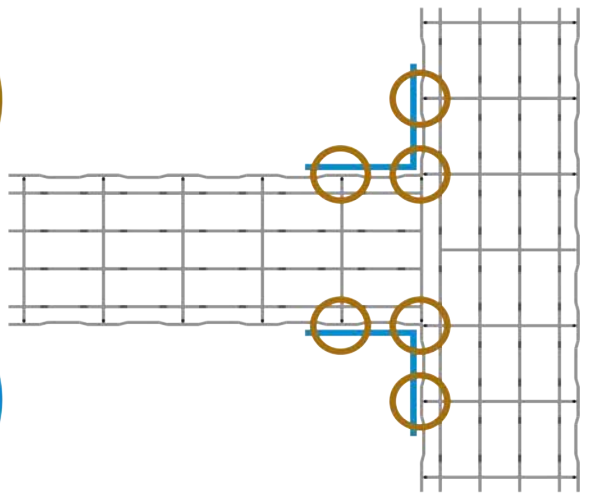
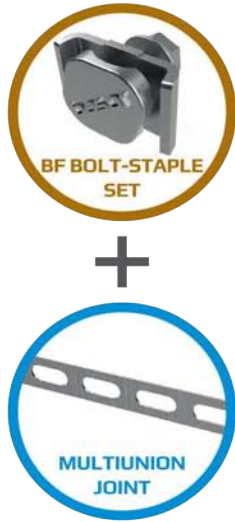

FAST BOLT NUT

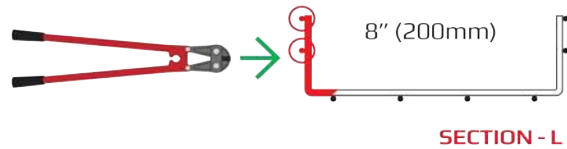

WIDTH		L	ACCESSORIES
2"	50mm	1	3x (BF Bolt-Staple Set + Multiunion joint)
4"	100mm	1	3x (BF Bolt-Staple Set + Multiunion joint)
6"	150mm	2	3x (BF Bolt-Staple Set + Multiunion joint)
8"	200mm	2	3x (BF Bolt-Staple Set + Multiunion joint)
12"	300mm	3	3x (BF Bolt-Staple Set + Multiunion joint)
16"	400mm	4	3x (BF Bolt-Staple Set + Multiunion joint)
20"	500mm	5	3x (BF Bolt-Staple Set + Multiunion joint)
24"	600mm	6	3x (BF Bolt-Staple Set + Multiunion joint)

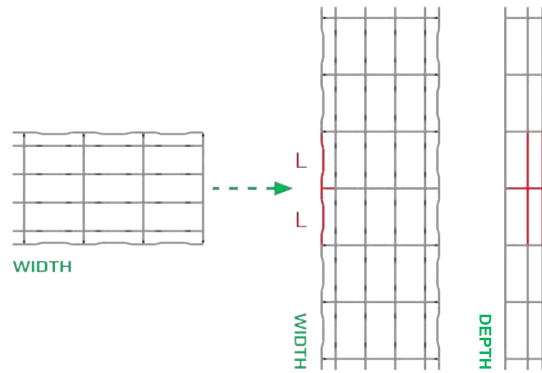

**L=Number of rows to cut**



## TEE OR CROSS LARGE RADIUS

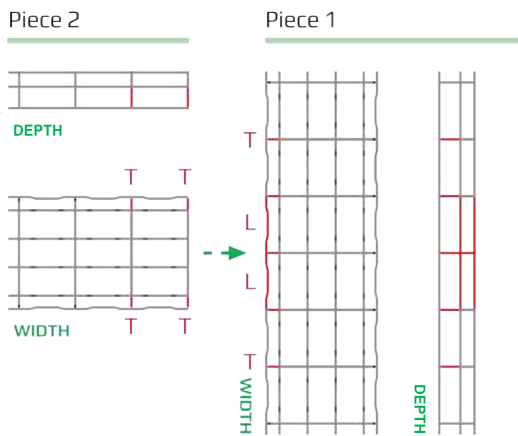
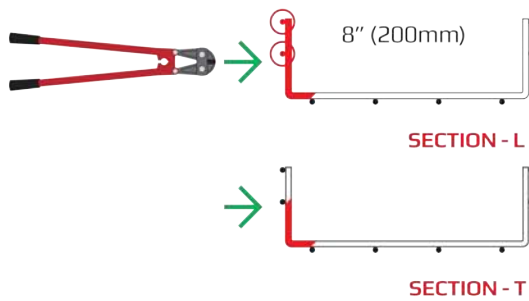
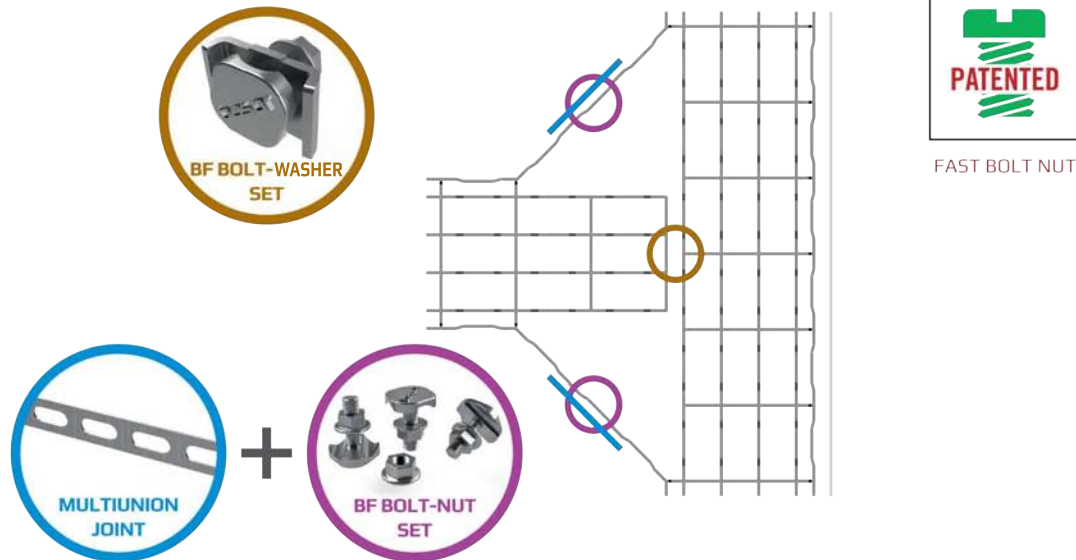

L and T=Number of rows to cut

WIDTH	Piece 1		Piece 2		ACCESSORIES
	L	T	L	T	
4"	100mm	2	1+1	1+1	3x (BF Bolt-Staple Set)
6"	150mm	3	1+1	1+1	1x (BF Bolt-Staple Set) + 2x (2x Bolt-Staple set + Multiunion Joint)
8"	200mm	3	1+1	1+1	3x (BF Bolt-Staple Set)
12"	300mm	4	1+1	1+1	4x (BF Bolt-Staple Set)
16"	400mm	5	1+1	1+1	1x (BF Bolt-Staple Set) + 2x (2x Bolt-Staple set + Multiunion Joint)
20"	500mm	6	1+1	1+1	4x (BF Bolt-Staple Set)
24"	600mm	7	1+1	1+1	4x (BF Bolt-Staple Set)



REDUCING SIZE - 4"

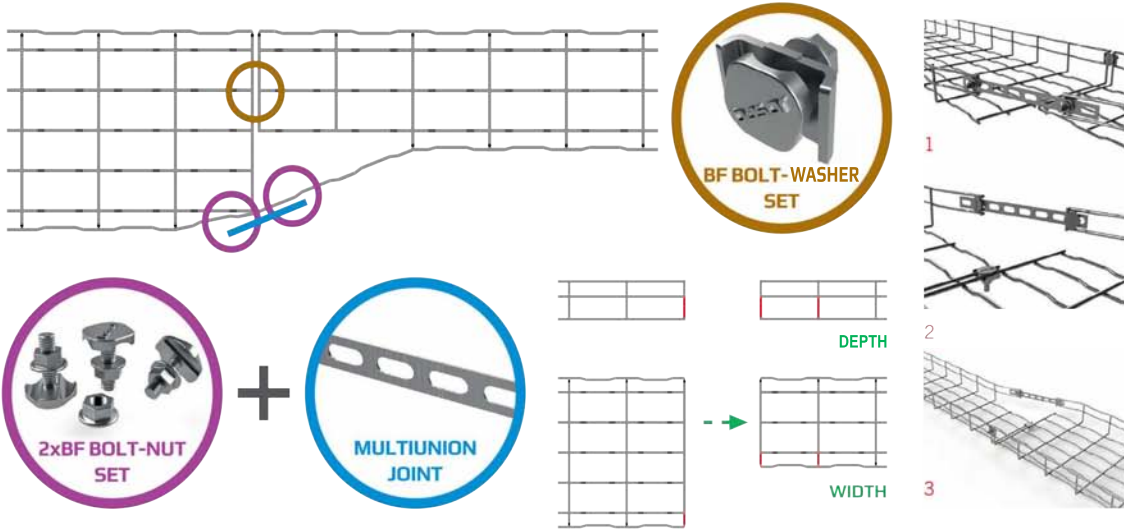

REDUCING SIZE - 8"

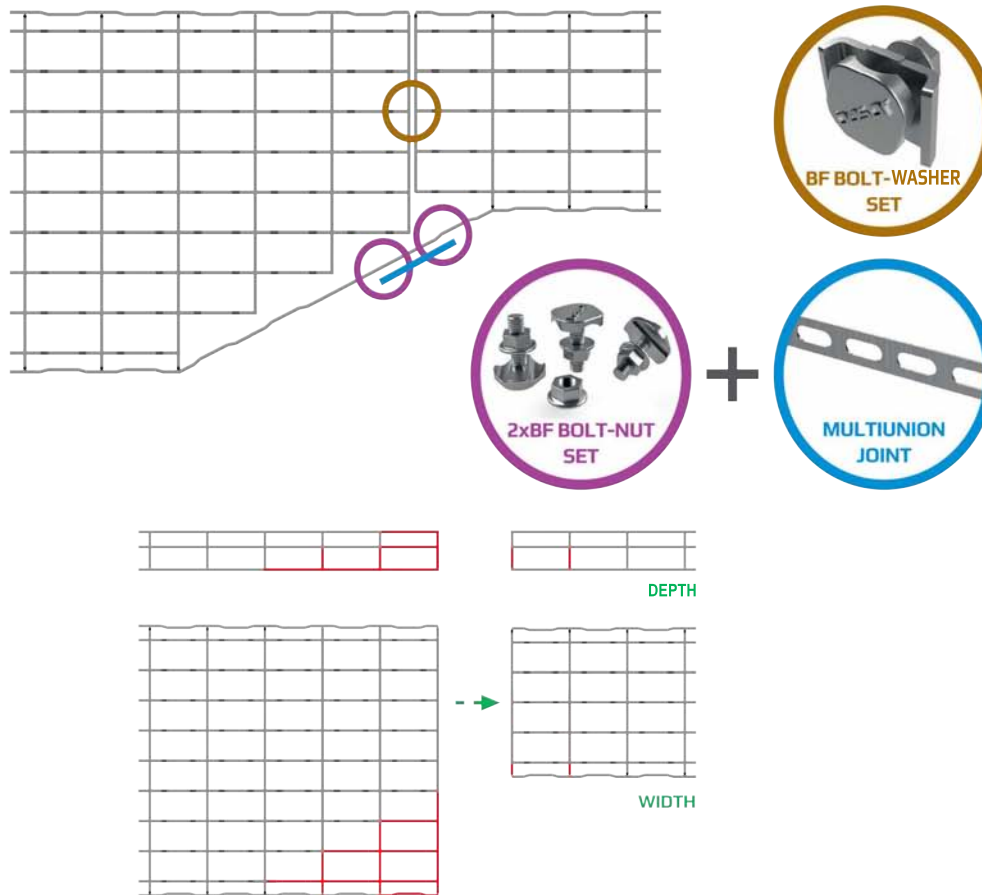

## VERTICAL BENDS

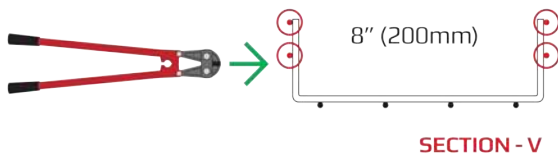
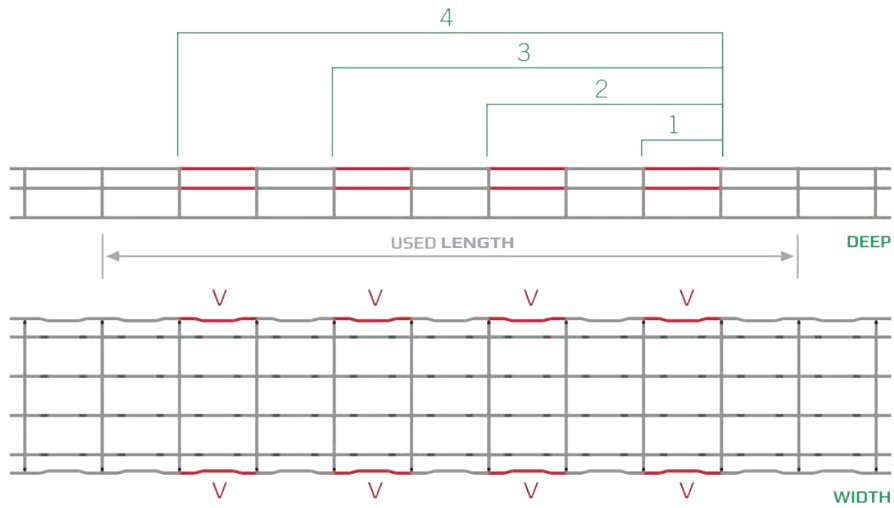

RADIUS	USED LENGTH	
	inches	mm
R1	3x4"	3x100
R2	5x4"	5x100
R3	7x4"	7x100
R4	9x4"	9x100

V=Number of rows to cut

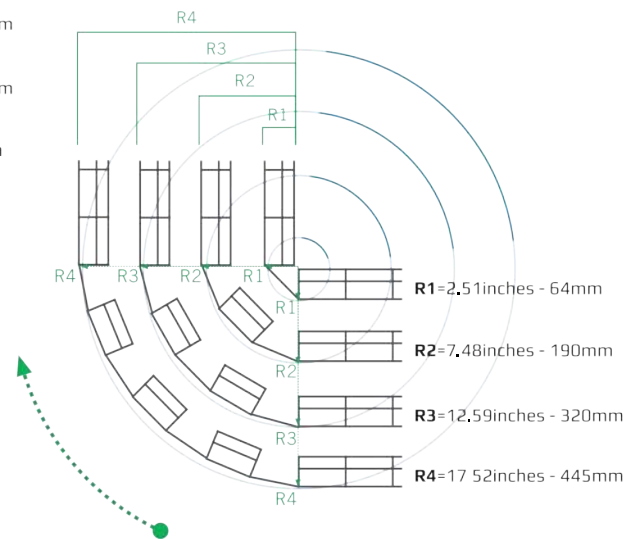
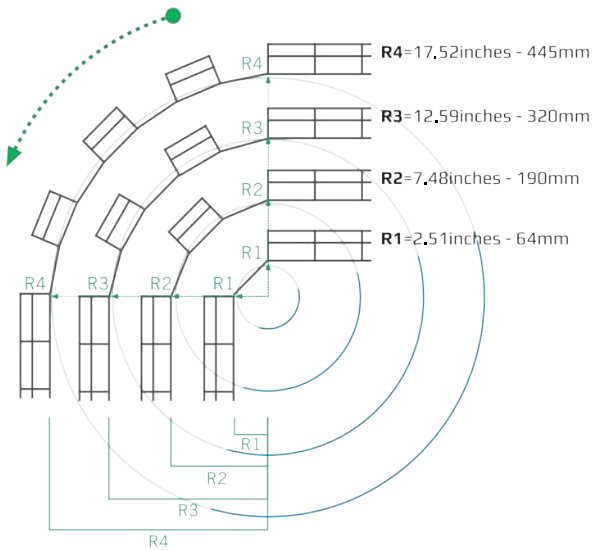

**CHANGING LEVEL**

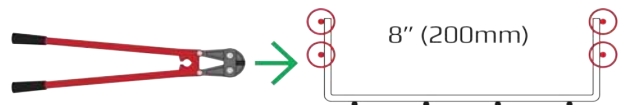
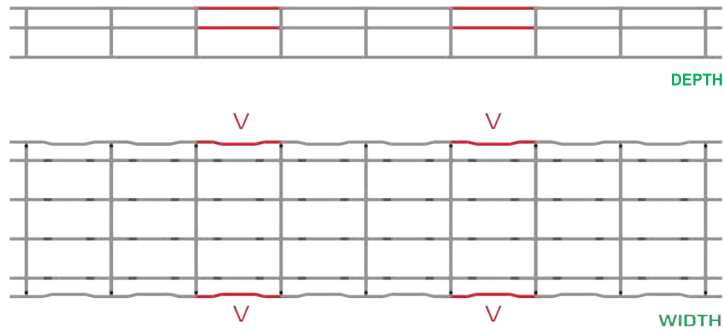

**SECTION - V**

V=Number of rows to cut

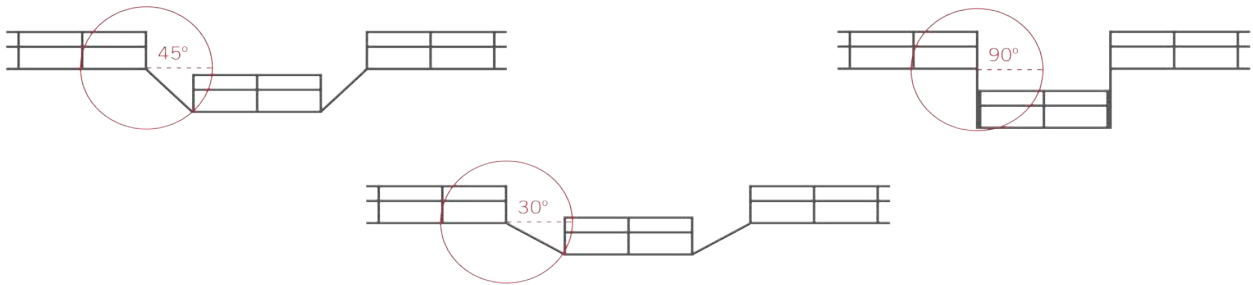

**BASORFIL GIVES YOU MANY POSSIBILITIES**

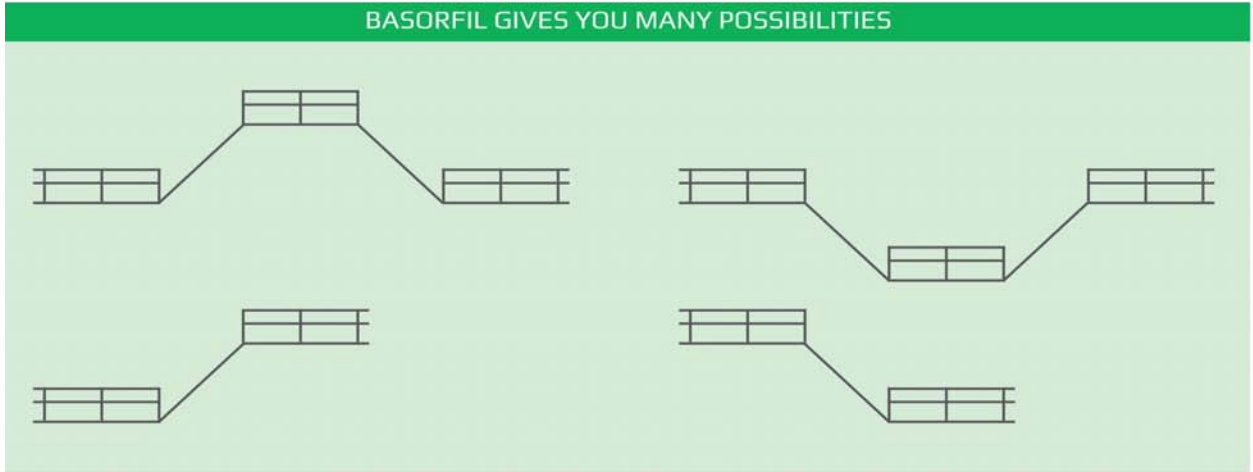



LARGE RADIUS HORIZONTAL BENDS

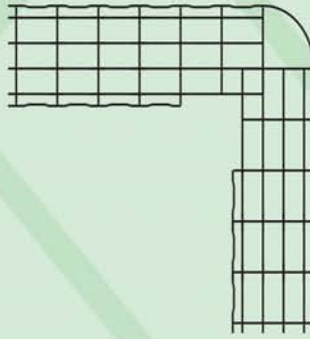

SMALL RADIUS HORIZONTAL BENDS

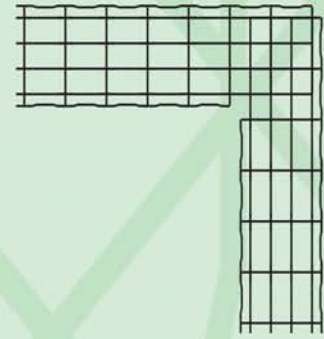

90° HORIZONTAL BENDS

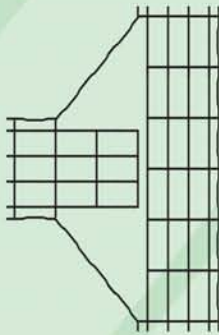

TEES AND CROSSES



REDUCING SIZE

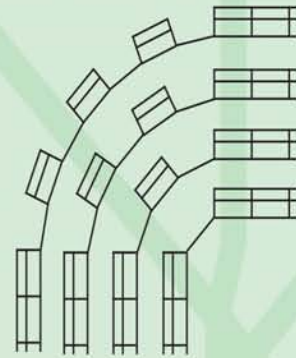

VERTICAL BENDS

**BE basor**  
E L E C T R I C

TEL: 618.476.6300  
FAX: 618.476.6301  
Toll Free: 844.393.3985  
[www.basor.com](http://www.basor.com)