



CHANNELL
Where The Industry Connects.®

ORDERING GUIDE

NEW!

GLB1111 Grade Level Box Greenbelt Applications

The GLB1111 grade level box is a high-grade blow-molded thermoplastic box for use in greenbelt applications, including broadband, telecommunications, irrigation and utilities. Superior to traditional round “flower pot” style handholes, the GLB1111 features a straight sidewall design to maximize cover load bearing capacity and minimize sidewall deflection. The GLB1111 is designed to comply with Telcordia GR-902-CORE specifications for greenway traffic environment.

Features

- Straight sidewall design for greater cover load bearing capacity and sidewall deflection
- Universal “L” bolt security system eliminates problem of lost cover bolts
- Optional private label available on cover
- “T” style overlapping cover design prevents soil from entering box when cover is removed

Specifications

Inside Dimension: 11" X 11" (279.4mm X 279.4mm)
Depth: 16" (406.4mm)



GLB1111 Grade Level Box (Cover Removed)



GLB1111 Grade Level Box

Ordering Information

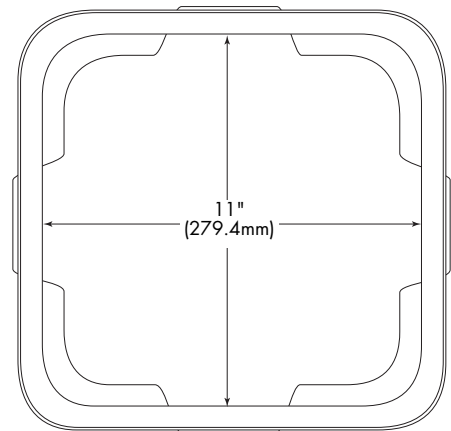
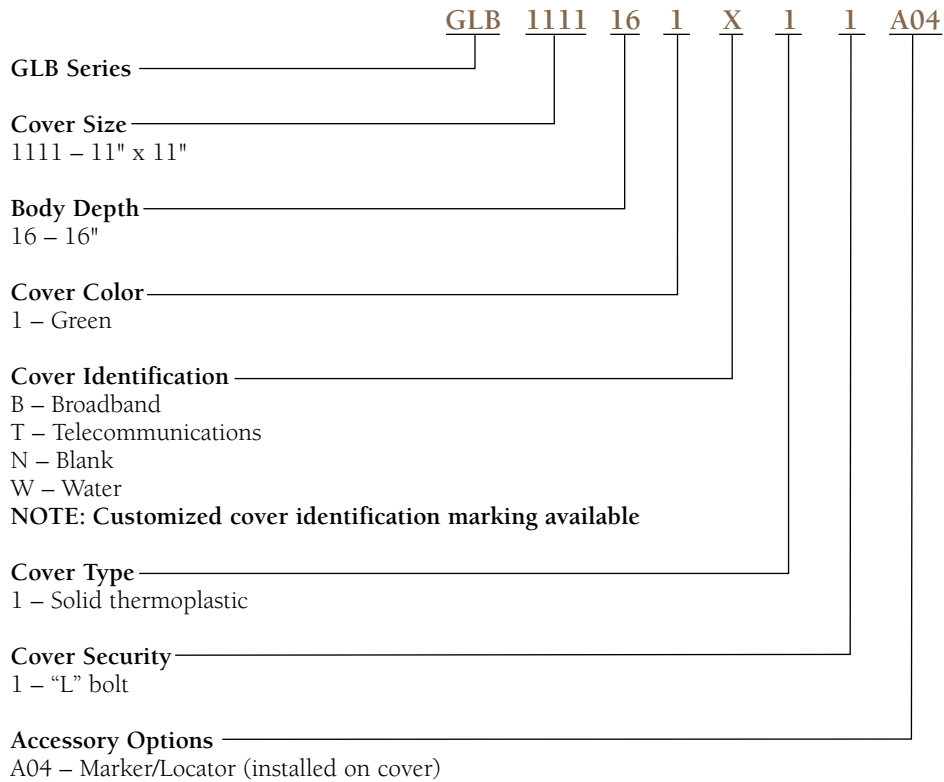

GLB1111 Grade Level Box
Interior Dimensions

Example: GLB1111161T11A04, GLB1111, 16" depth, green cover, Telecommunications cover identification, solid thermoplastic cover, "L" bolt security, with marker locator

"L" Bolt Cover Security



(Top View)



(Bottom View)

Marker/Locator



CHANNELL

Where The Industry Connects.®

USA: Channell Commercial Corporation, Temecula, CA • Tel.800.423.1863 • Fax.951.296.2322

CANADA: Channell Canada, Inc. • Tel. 905.565.1700 • Fax. 905.565.8080

EUROPE, MIDDLE EAST, AFRICA: Channell Ltd., London, UK • Tel. 44.1689.871522 • Fax 44.1689.833428

AUSTRALIA, ASIA, PACIFIC RIM: Channell Pty. Ltd., Sydney, Australia • Tel.61.2.9738.8277 • Fax.61.2.9738.9763

WORLDWIDE HEADQUARTERS: Channell Commercial Corporation • 951.719.2600 • 26040 Ynez Road • P.O. Box 9022 • Temecula, CA 92589-9022, USA